

Please write clearly in block capitals.

Centre number

Candidate number

Surname _____

Forename(s) _____

Candidate signature _____

I declare this is my own work.

A-level PHYSICS

Paper 1

Monday 18 May 2020

Afternoon

Time allowed: 2 hours

Materials

For this paper you must have:

- a pencil and a ruler
- a scientific calculator
- a Data and Formulae Booklet.

Instructions

- Use black ink or black ball-point pen.
- Fill in the boxes at the top of this page.
- Answer **all** questions.
- You must answer the questions in the spaces provided. Do not write outside the box around each page or on blank pages.
- If you need extra space for your answer(s), use the lined pages at the end of this book. Write the question number against your answer(s).
- Do all rough work in this book. Cross through any work you do not want to be marked.
- Show all your working.

Information

- The marks for questions are shown in brackets.
- The maximum mark for this paper is 85.
- You are expected to use a scientific calculator where appropriate.
- A Data and Formulae Booklet is provided as a loose insert.

For Examiner's Use	
Question	Mark
1	
2	
3	
4	
5	
6–30	
TOTAL	

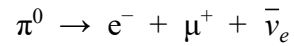

Section AAnswer **all** questions in this section.**0 1 . 1** Determine whether the following reaction is a possible decay for the neutral pion π^0 .**[2 marks]**

0 1 . 2 State the **two** possible quark configurations of a π^0 .**[1 mark]**1

2

0 1 . 3 A student suggests that the kaon K^0 and the anti-kaon \bar{K}^0 are the same particle.

Discuss whether this suggestion is correct.

[2 marks]



0 2

Figure 1 shows an arrangement used to investigate the photoelectric effect.

Figure 1

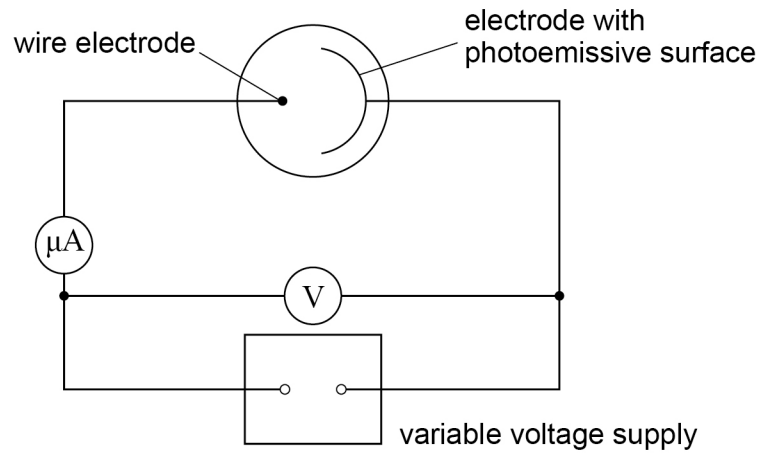

A current is measured on the microammeter only when electromagnetic radiation with a frequency greater than a certain value is incident on the photoemissive surface.

0 2 . 1

Explain why the frequency of the electromagnetic radiation must be greater than a certain value.

[2 marks]



The apparatus in **Figure 1** is used with a monochromatic light source of constant intensity. Measurements are made to investigate how the current I in the microammeter varies with positive and negative values of the potential difference V of the variable voltage supply.

Figure 2 shows how the results of the investigation can be used to find the stopping potential.

Figure 2

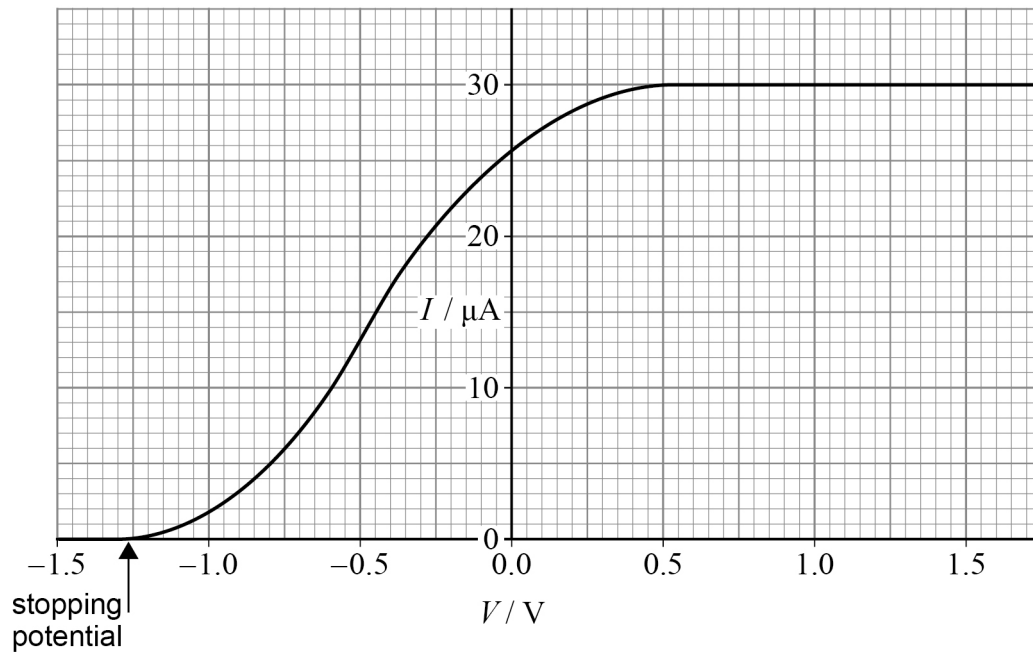

0 2 . 2

Determine the number of photoelectrons per second leaving the photoemissive surface when the current is a maximum.

[2 marks]

number of photoelectrons per second = _____

Question 2 continues on the next page

Turn over ►



0 2 . 3Explain why I reaches a constant value for positive values of V .**[2 marks]**

0 2 . 4Explain why I decreases as the value of V becomes more negative.**[3 marks]**



0 3

A student investigates the interference of sound waves using two loudspeakers, **P** and **Q**, connected to a signal generator (oscillator). Each loudspeaker acts as a point source of sound.

Figure 3 shows the arrangement.

Figure 3

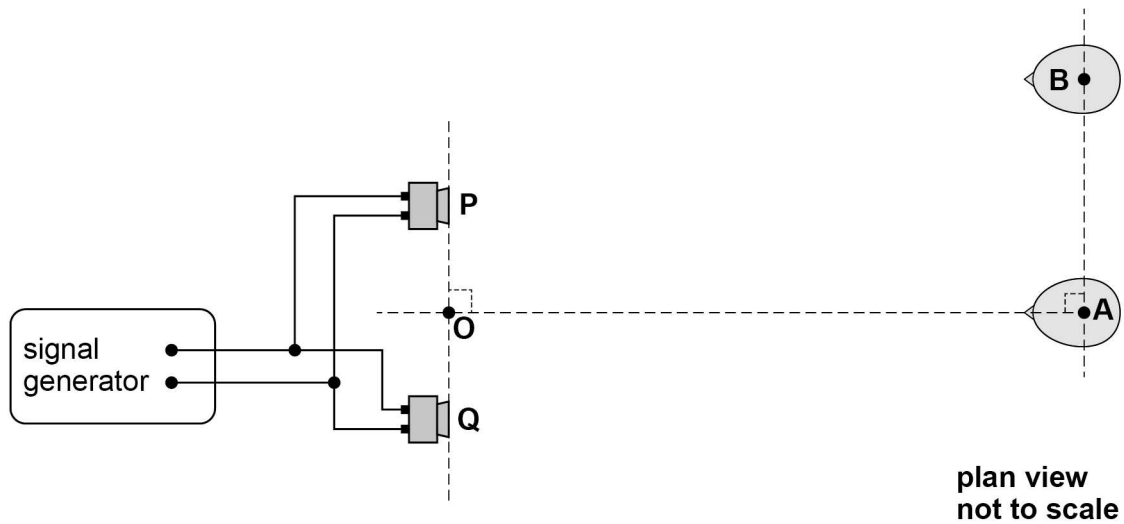

Point **O** is the midpoint between **P** and **Q**.

0 3 . 1

Explain why the two loudspeakers are coherent sources of sound waves.

[2 marks]



0 3 . 3 The student records the following data:

separation of the two loudspeakers = 0.30 m

distance **OA** = 2.25 m

distance from **A** to **B** = 0.95 m

Show that the path difference for the sound waves from the two loudspeakers to point **B** is about 0.1 m.

[3 marks]

0 3 . 4 The frequency of the sound wave is 2960 Hz.

Calculate the speed of sound from the student's data.

[1 mark]

speed of sound = _____ m s⁻¹



There are no questions printed on this page

*Do not write
outside the
box*

**DO NOT WRITE ON THIS PAGE
ANSWER IN THE SPACES PROVIDED**



0 4

A pair of cameras is used on a motorway to help determine the average speed of vehicles travelling between the two cameras.

Figure 5 shows the speed–time graph for a car moving between the two cameras.

Figure 5

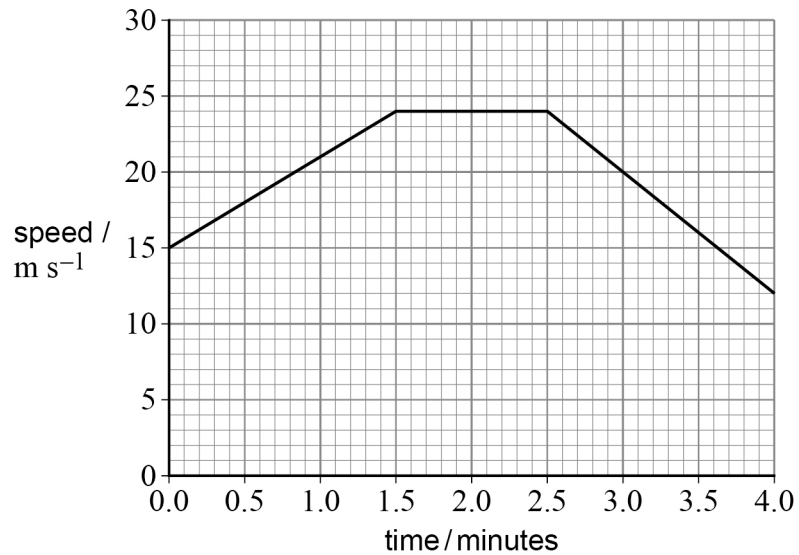

0 4 . 1

The speed limit for the motorway between the two cameras is 22 m s^{-1} .

Determine whether the average speed of the car exceeded this speed limit.

[3 marks]

Question 4 continues on the next page

Turn over ►



0 4 . 2 Markings called chevrons are used on motorways.

The chevron separation is designed to give a driver time to respond to any change in speed of the car in front. The driver is advised to keep a minimum distance d behind the car in front, as shown in **Figure 6**.

Figure 6

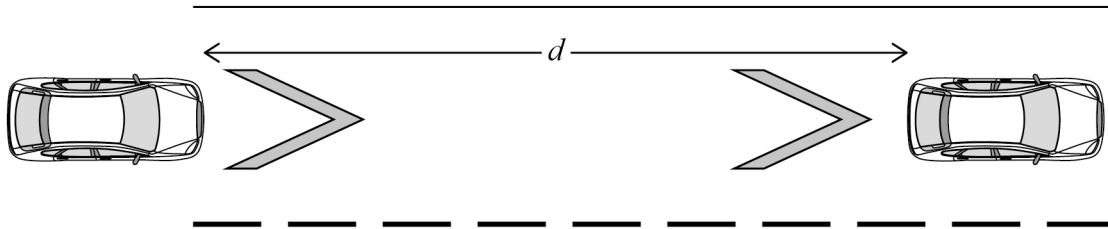

not to scale

Government research suggests that the typical time for a driver to respond is between 1.6 s and 2.0 s.

Suggest a value for d where the speed limit is 31 m s^{-1} .

[2 marks]

$d =$ _____ m



0 4 . 3

The chevron separation is based on the response time, not on the time taken for a car to stop.

The brakes of a car are applied when its speed is 31 m s^{-1} and the car comes to rest. The total mass of the car is 1200 kg.

The average braking force acting on the car is 6.8 kN.

Calculate the time taken for the braking force to stop the car **and** the distance travelled by the car in this time.

[4 marks]

time = _____ s

distance = _____ m

0 4 . 4

Suggest why the chevron separation on motorways does not take into account the distance travelled as a car comes to rest after the brakes are applied.

[1 mark]

Question 4 continues on the next page

Turn over ►



0 4 . 5

At bends on motorways the road is sloped so that a car is less likely to slide out of its lane when travelling at a high speed.

Figure 7 shows a car of mass 1200 kg travelling around a curve of radius 200 m. The motorway is sloped at an angle of 5.0° .

Figure 8 shows the weight W and reaction force N acting on the car. The advisory speed for the bend is chosen so that the friction force down the slope is zero.

Figure 7

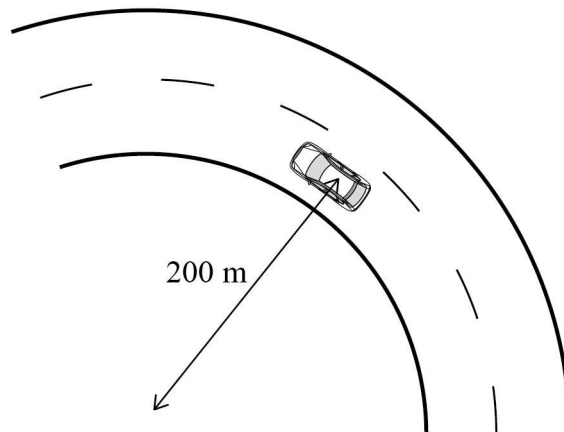
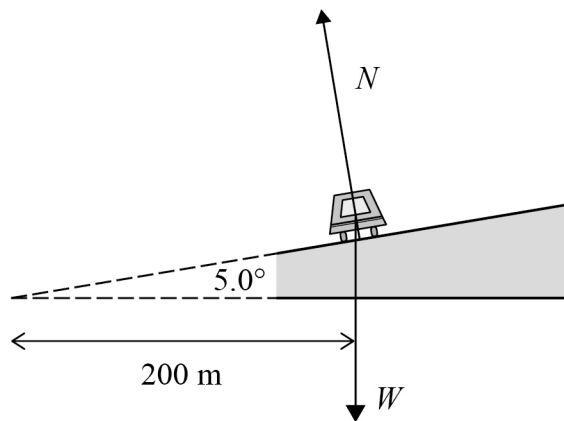

Figure 8



Suggest an appropriate advisory speed for this section of the motorway.

[4 marks]

*Do not write
outside the
box*

advisory speed = _____ m s⁻¹

14

Turn over for the next question

Turn over ►



0 5

Figure 9 shows some of the apparatus used in a demonstration of electrical power transmission using a dc power supply.

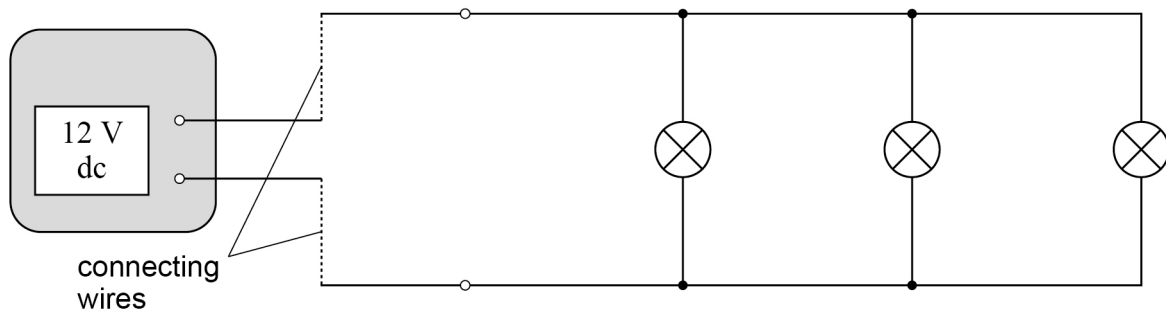
Figure 9

A power supply of emf 12 V and negligible internal resistance is connected to three identical 12 V, 1.5 W lamps in parallel.

0 5 . 1

Show that the resistance of one of the lamps when it is operating at 12 V is about 100 Ω .

[1 mark]

0 5 . 2

Initially the power supply is connected to the lamps using two short copper wires of negligible resistance.

Calculate the current in the power supply.

[2 marks]

current = _____ A



0 5 . 3

The two short copper wires are replaced with two long constantan wires.

Show that the resistance of each length of constantan wire is about 50Ω .

length of each constantan wire = 2.8 m
diameter of constantan wires = 0.19 mm
resistivity of constantan = $4.9 \times 10^{-7} \Omega \text{ m}$

[3 marks]**0 5 . 4**

The demonstration is intended to show that the lamps are significantly dimmer when connected using the long constantan wires than when using the short copper wires.

Discuss whether the demonstration achieves this.
Support your answer with suitable calculations.

[4 marks]

Question 5 continues on the next page

Turn over ►

0 5 . 5

Scientists and engineers are investigating the use of superconductors in electrical transmission.

Discuss **one** advantage and **one** difficulty when using superconductors in electrical transmission over long distances.

[3 marks]

Advantage _____

Difficulty _____

13

END OF SECTION A



Section B

Each of Questions **06** to **30** is followed by four responses, **A**, **B**, **C** and **D**.

For each question select the best response.

Only **one** answer per question is allowed.

For each question, completely fill in the circle alongside the appropriate answer.

CORRECT METHOD

WRONG METHODS

If you want to change your answer you must cross out your original answer as shown. 

If you wish to return to an answer previously crossed out, ring the answer you now wish to select as shown. 

You may do your working in the blank space around each question but this will not be marked.
Do **not** use additional sheets for this working.

06 Mechanical power

[1 mark]

- A** is a vector quantity.
- B** is measured in J.
- C** has base units of $\text{kg m}^2 \text{s}^{-3}$.
- D** can be calculated from force \times distance moved.

07 Water waves of wavelength λ and wave speed v are related by $v = \sqrt{k\lambda}$ where k is a constant.

What is a possible SI unit for k ?

[1 mark]

- A** m s^{-2}
- B** m s^{-1}
- C** $\text{m}^{\frac{3}{2}} \text{s}^{-1}$
- D** $\text{m}^{\frac{1}{2}} \text{s}^{-1}$

Turn over ►



0 8A photon has energy of 1×10^{18} eV.

An object of mass 0.03 kg has kinetic energy equal to the energy of the photon.

What is the speed of the object?

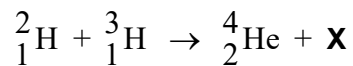
[1 mark]**A** 1 m s^{-1} **B** 3 m s^{-1} **C** 10 m s^{-1} **D** 30 m s^{-1} **0 9**A deuterium nucleus and a tritium nucleus fuse together to produce a helium nucleus and particle **X**.What is **X**?**[1 mark]****A** an electron **B** a neutron **C** a positron **D** a proton **1 0**The radioactive nuclide ${}^{232}_{90}\text{Th}$ decays by one α emission followed by two β^- emissions.

Which nuclide is formed as a result of these decays?

[1 mark]**A** ${}^{238}_{92}\text{U}$ **B** ${}^{230}_{90}\text{Th}$ **C** ${}^{228}_{90}\text{Th}$ **D** ${}^{228}_{88}\text{Rn}$ 

1 1 What quantity is measured in kW h?

[1 mark]

- A** charge
- B** current
- C** energy
- D** power

1 2 An electron collides with an isolated atom and raises an atomic electron to a higher energy level.

Which statement is correct?

[1 mark]

- A** The colliding electron is captured by the nucleus of the atom.
- B** A photon is emitted when the electron rises to the higher energy level.
- C** An electron is emitted when the excited electron returns to the ground state.
- D** The colliding electron transfers energy to the atomic electron.

Turn over for the next question

Turn over ►



1 3

Which graph shows the variation of momentum p with wavelength λ of a photon?

[1 mark]

A

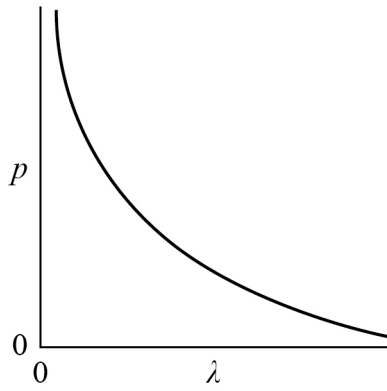

B

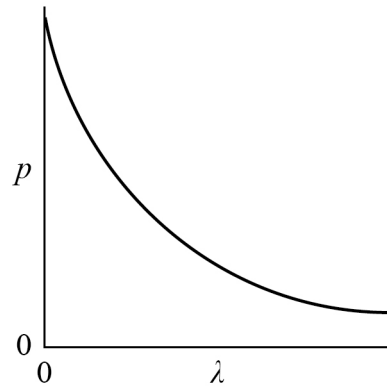

C

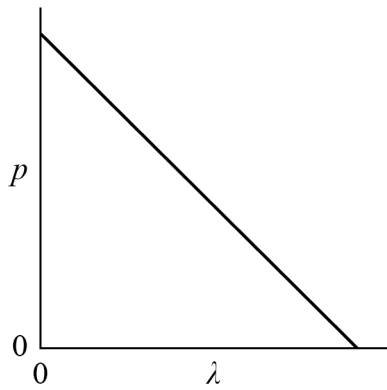

D

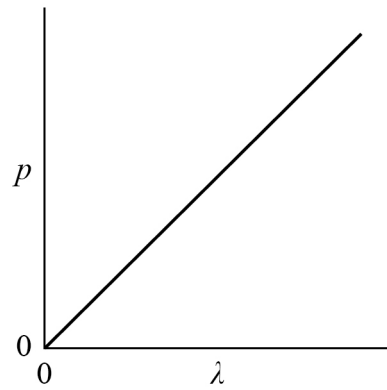
A B C D 

1 4

A monochromatic light wave travels from glass into air.

Which row shows what happens to the wavelength, speed and photon energy?

[1 mark]

	Wavelength	Speed	Photon energy	
A	increases	increases	increases	<input type="radio"/>
B	does not change	decreases	does not change	<input type="radio"/>
C	does not change	decreases	increases	<input type="radio"/>
D	increases	increases	does not change	<input type="radio"/>

1 5

A wave travels across the surface of water.

The diagram shows how the displacement of water particles at the surface varies with distance.

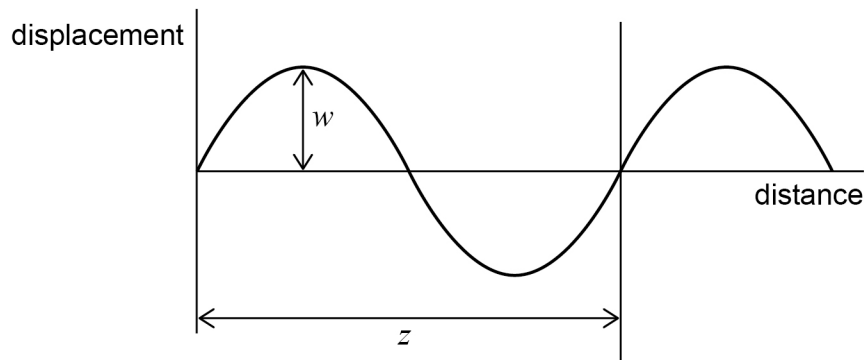

Which row correctly describes both w and z ?

[1 mark]

	w	z	
A	amplitude	wavelength	<input type="radio"/>
B	half-amplitude	period	<input type="radio"/>
C	half-amplitude	wavelength	<input type="radio"/>
D	amplitude	period	<input type="radio"/>

Turn over ►

1 6

The diagram shows the cross-section of a progressive transverse wave travelling at 24 cm s^{-1} on water. The amplitude of the wave is 2.0 cm and the frequency is 4.0 Hz .

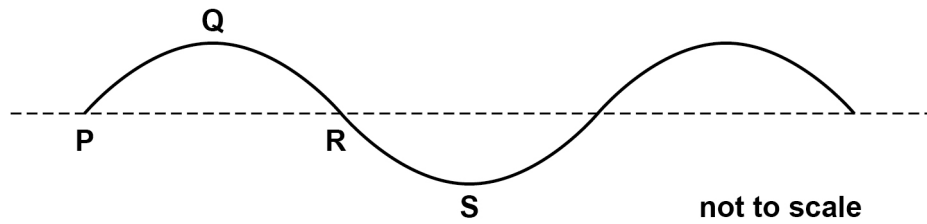

Which statement is correct?

[1 mark]

- A** The phase difference between particles at **P** and **S** is $\frac{\pi}{2}$ rad.
- B** The distance between **P** and **R** is 6.0 cm .
- C** The particle velocity at **Q** is a maximum.
- D** Particles at **P** and **R** are in phase.



1 7

Unpolarised light travels through two polarising filters **X** and **Y** and is then incident on a screen. When **X** and **Y** are arranged as shown, there is a maximum intensity on the screen.

X is held stationary but **Y** is rotated in a plane at right angles to the beam so that θ increases.

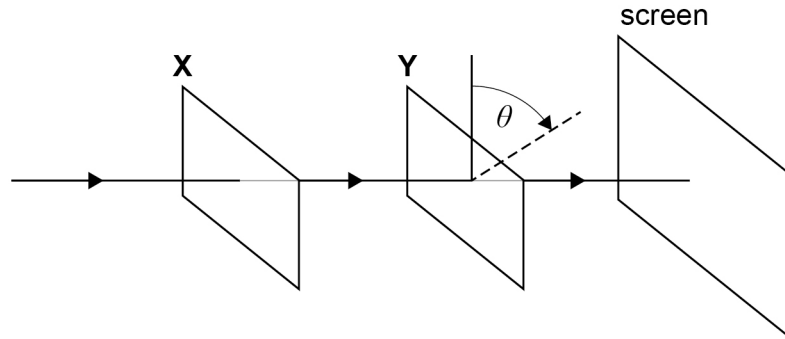

What are the next three values of θ , in rad, for which the beam hits the screen with maximum intensity?

[1 mark]

A $\frac{\pi}{2}, \frac{2\pi}{2}, \frac{3\pi}{2}$

B $\frac{\pi}{2}, \frac{3\pi}{2}, \frac{5\pi}{2}$

C $\pi, 2\pi, 3\pi$

D $2\pi, 4\pi, 6\pi$

1 8

Stationary waves are set up on a rope of length 1.0 m fixed at both ends.

Which statement is **not** correct?

[1 mark]

A The first harmonic has a wavelength of 2.0 m.

B The midpoint of the rope is always stationary for even-numbered harmonics.

C A harmonic of wavelength 0.4 m can be set up on the rope.

D There are five nodes on the rope for the fifth harmonic.

Turn over ►



1 9

Monochromatic light is incident normally on a diffraction grating that has $4.50 \times 10^5 \text{ lines m}^{-1}$.
The angle between the second-order diffraction maxima is 44° .

What is the wavelength of the light?

[1 mark]

A 208 nm

B 416 nm

C 772 nm

D 832 nm

2 0

The diagram shows the forces acting on a uniform rod.

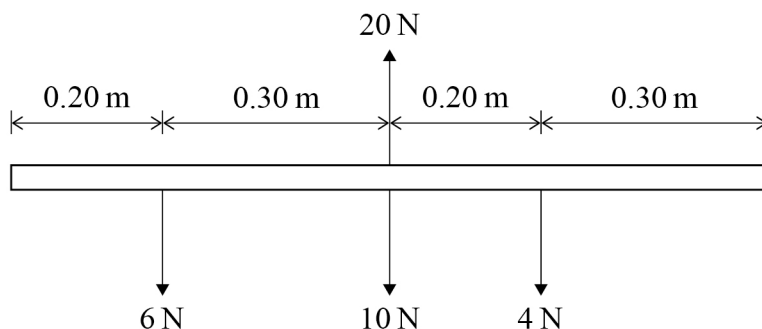

Which statement is correct?

[1 mark]

A The rod is in equilibrium.

B For equilibrium, an anticlockwise moment of 1.0 N m is needed.

C For equilibrium, a clockwise moment of 1.0 N m is needed.

D For equilibrium, the 10 N force should be increased to 20 N .



2 | 1

Small water drops leave a tap with zero velocity at intervals of 0.20 s. They then fall freely 0.80 m to reach a horizontal surface.

How far has a drop fallen when the previous drop hits the surface?

[1 mark]

A 0.16 m

B 0.20 m

C 0.40 m

D 0.60 m

2 | 2

A pellet with velocity 200 m s^{-1} and mass 5.0 g is fired vertically upwards into a stationary block of mass 95.0 g. The pellet remains in the block. The impact causes the block to move vertically upwards.

What is the maximum vertical displacement of the block?

[1 mark]

A 5.1 m

B 10 m

C 51 m

D 100 m

2 | 3

An electric motor lifts a load of weight W through a vertical height h in time t . The potential difference across the motor is V and the current in it is I .

What is the efficiency of the motor?

[1 mark]

A $\frac{Wh}{VI}$

B $\frac{VI}{Wh}$

C $\frac{Wh}{VI}$

D $\frac{VI}{Wh}$

Turn over ►

2 4

A particle of mass m undergoes simple harmonic motion with amplitude A and frequency f .

What is the total energy of the particle?

[1 mark]

A $2\pi mfA^2$

B $2\pi^2 mf^2 A^2$

C $4\pi^2 m^2 f^2 A$

D $4\pi^2 mf^2 A^2$

2 5

A mass of 0.90 kg is suspended from the lower end of a light spring of stiffness 80 N m^{-1} .

When the mass is displaced vertically and released, it undergoes vertical oscillations of small amplitude.

What is the frequency of the oscillations?

[1 mark]

A 0.071 Hz

B 0.67 Hz

C 1.50 Hz

D 14 Hz



2 6

An experiment is carried out to determine the Young modulus E of steel using a vertical wire of initial length L and cross-sectional area A . Various weights are suspended from the wire. A graph of extension against weight is plotted.

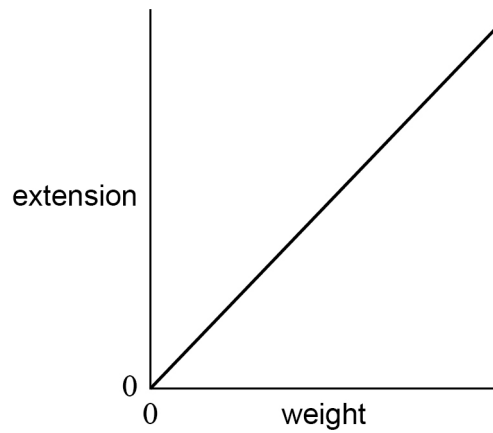

What does the gradient of the graph represent?

[1 mark]

A E

B $\frac{1}{E}$

C $\frac{EA}{L}$

D $\frac{L}{EA}$

Turn over for the next question

Turn over ►



2 7 In the circuit below, the voltmeter reading is zero.

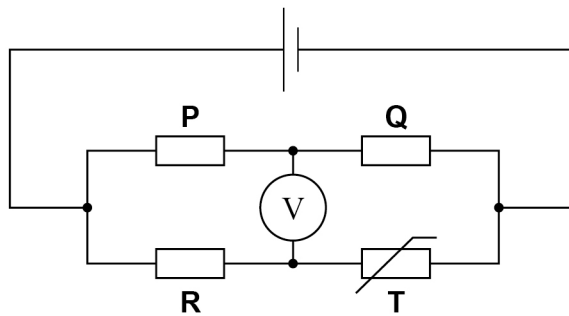

When the temperature of the thermistor **T** is increased, the voltmeter reading changes.

Which change to the circuit will restore the voltmeter to zero?

[1 mark]

- A** a reduction in the emf of the cell
- B** a reduction in the resistance of **P**
- C** an increase in the resistance of **Q**
- D** a reduction in the resistance of **R**



2 8

A resistor of resistance R and three identical cells of emf E and internal resistance r are connected as shown.

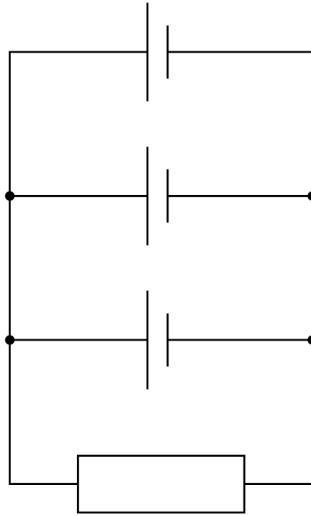

What is the current in the resistor?

[1 mark]

A $\frac{3E}{(3R+r)}$

B $\frac{9E}{(3R+r)}$

C $\frac{E}{R}$

D $\frac{3E}{R}$

Turn over for the next question

Turn over ►



2 9

In the circuit, the reading of the voltmeter is V .

When the switch is closed the reading becomes $\frac{V}{3}$.

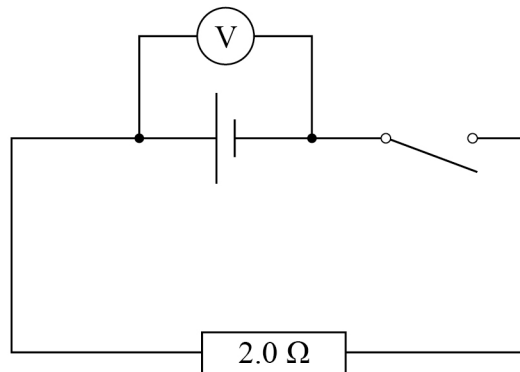

What is the internal resistance of the cell?

[1 mark]

- A** 0.33 Ω
- B** 0.67 Ω
- C** 4.0 Ω
- D** 6.0 Ω

3 0

The period of a simple pendulum is doubled when the pendulum length is increased by 1.8 m.

What is the original length of the pendulum?

[1 mark]

- A** 0.45 m
- B** 0.60 m
- C** 0.90 m
- D** 3.6 m

25**END OF QUESTIONS**

There are no questions printed on this page

*Do not write
outside the
box*

**DO NOT WRITE ON THIS PAGE
ANSWER IN THE SPACES PROVIDED**



There are no questions printed on this page

*Do not write
outside the
box*

**DO NOT WRITE ON THIS PAGE
ANSWER IN THE SPACES PROVIDED**

Copyright information

For confidentiality purposes, all acknowledgements of third-party copyright material are published in a separate booklet. This booklet is published after each live examination series and is available for free download from www.aqa.org.uk.

Permission to reproduce all copyright material has been applied for. In some cases, efforts to contact copyright-holders may have been unsuccessful and AQA will be happy to rectify any omissions of acknowledgements. If you have any queries please contact the Copyright Team.

Copyright © 2020 AQA and its licensors. All rights reserved.

