

Write your name here

Surname

Other names

Pearson Edexcel
International GCSE

Centre Number

--	--	--	--	--	--

Candidate Number

--	--	--	--	--

Mathematics A

Level 1/2
Paper 1F



Foundation Tier

Thursday 24 May 2018 – Morning
Time: 2 hours

Paper Reference

4MA1/1F

You must have:

Ruler graduated in centimetres and millimetres, protractor, compasses, pen, HB pencil, eraser, calculator. Tracing paper may be used.

Total Marks

--

Instructions

- Use **black** ink or ball-point pen.
- **Fill in the boxes** at the top of this page with your name, centre number and candidate number.
- Answer **all** questions.
- Without sufficient working, correct answers may be awarded no marks.
- Answer the questions in the spaces provided
– *there may be more space than you need.*
- **Calculators may be used.**
- You must **NOT** write anything on the formulae page.
Anything you write on the formulae page will gain **NO** credit.

Information

- The total mark for this paper is 100.
- The marks for **each** question are shown in brackets
– *use this as a guide as to how much time to spend on each question.*

Advice

- Read each question carefully before you start to answer it.
- Check your answers if you have time at the end.

Turn over ►

P54692A

©2018 Pearson Education Ltd.

1/1/1/



Pearson

International GCSE Mathematics
Formulae sheet – Foundation Tier

Area of trapezium = $\frac{1}{2}(a + b)h$

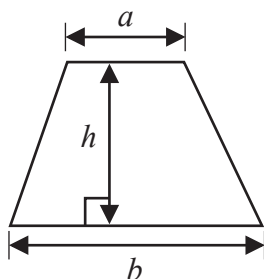

Volume of prism = area of cross section \times length

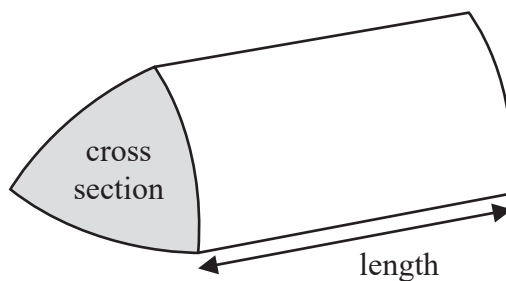

Volume of cylinder = $\pi r^2 h$

Curved surface area of cylinder = $2\pi r h$

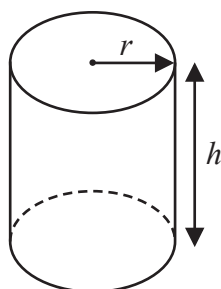

DO NOT WRITE IN THIS AREA

DO NOT WRITE IN THIS AREA

DO NOT WRITE IN THIS AREA



Answer ALL TWENTY ONE questions.

Write your answers in the spaces provided.

You must write down all the stages in your working.

- 1 (a) Write $\frac{7}{100}$ as a decimal.

.....
(1)

- (b) Write $\frac{48}{60}$ as a fraction in its simplest form.

.....
(1)

- (c) Write $\frac{17}{3}$ as a mixed number.

.....
(1)

There are 840 tickets available for a concert.

$\frac{1}{7}$ of these tickets have **not** been sold.

- (d) How many of the tickets have been sold?

.....
(2)

(Total for Question 1 is 5 marks)



- 2 The bar chart gives information about the total number of medals won by each of six countries at the 2016 Olympic Games.

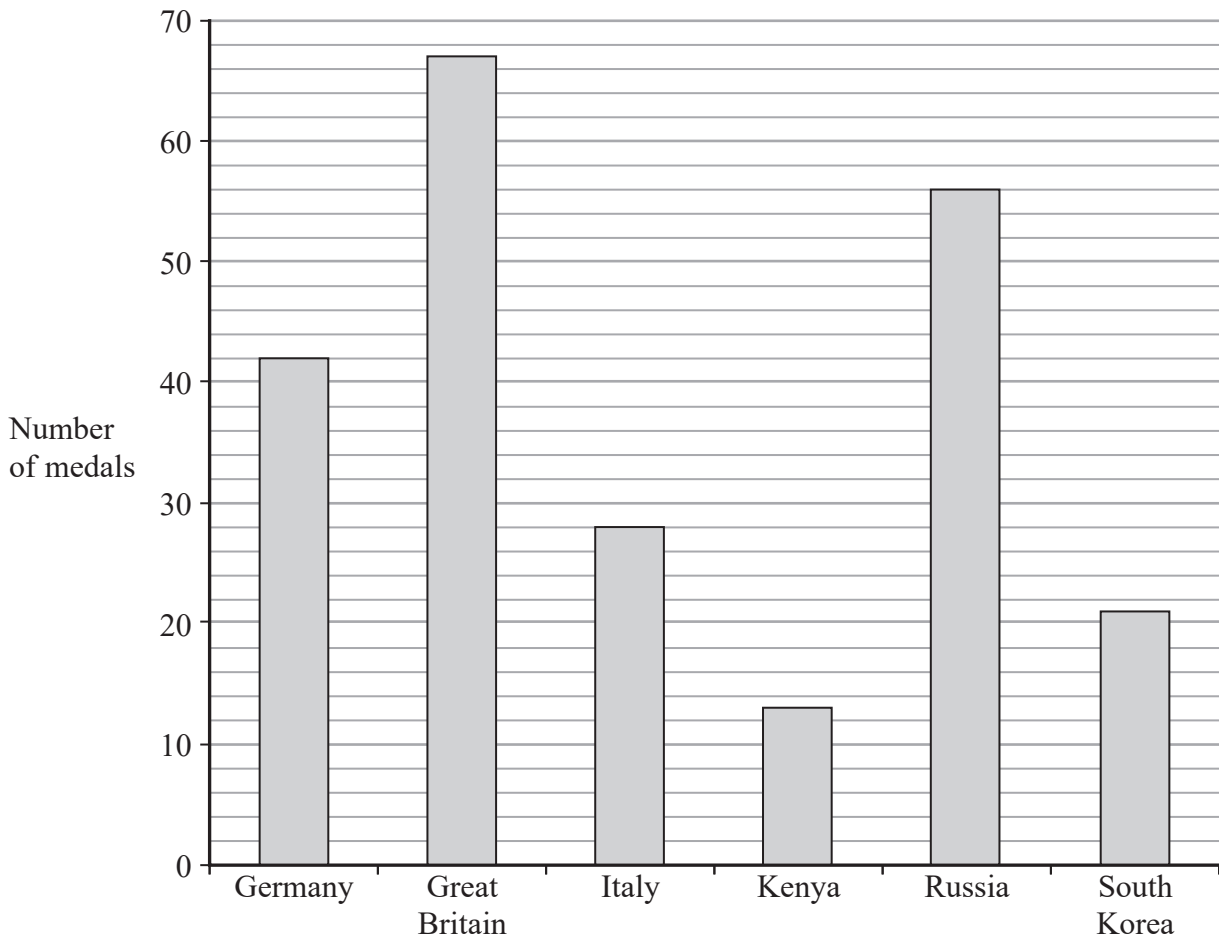

- (a) Which of these countries won the fewest total number of medals?

.....
(1)

Great Britain won 27 gold medals.

- (b) How many of the medals won by Great Britain were **not** gold medals?

.....
(2)



- (c) Write down the ratio of the total number of medals won by Russia to the total number of medals won by Germany.
Give your ratio in its simplest form.

.....
(2)

The USA won

46 gold medals
37 silver medals
38 bronze medals

- (d) What fraction of the total number of medals won by the USA were gold medals?

.....
(2)

(Total for Question 2 is 7 marks)

- 3 (i) Write down the mathematical name of this 3-D shape.

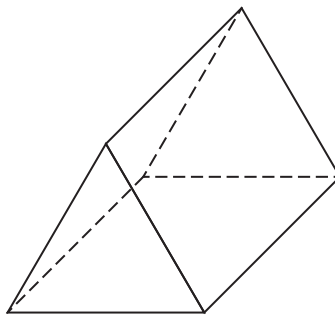

- (ii) How many faces does the shape have?

- (iii) How many vertices does the shape have?

.....
(Total for Question 3 is 3 marks)



4 (a) Change 650 centimetres into metres.

..... metres
(1)

(b) Change 8 litres into millilitres.

..... millilitres
(1)

Memona has a 6 kg sack of rice and some empty bags.
She fills each bag with 475 grams of rice from the sack.

(c) How many bags can Memona completely fill with rice?

.....
(3)

(Total for Question 4 is 5 marks)



5 (a) Simplify $6x + 8x - 3x$

.....
(1)

(b) Simplify $4e \times 5f$

.....
(1)

(c) Solve $8p = 24$

$p =$
(1)

(d) Solve $k - 4 = 13$

$k =$
(1)

(e) Simplify $10t + 4d - 3t + 2d$

.....
(2)

(Total for Question 5 is 6 marks)



- 6 The two-way table shows some information about where 50 people went for their last holiday.

	UK	Africa	USA	Total
Male			2	23
Female	16	9		
Total		16		50

- (a) Complete the table.

(3)

- (b) What percentage of these 50 people were female **and** went on holiday in Africa?

..... %

(2)

(Total for Question 6 is 5 marks)

- 7 3 kg of potatoes and 2 kg of apples cost a total of £7.33
4 kg of potatoes cost £3.80

Work out the cost of 1 kg of apples.

£.....

(Total for Question 7 is 4 marks)



8

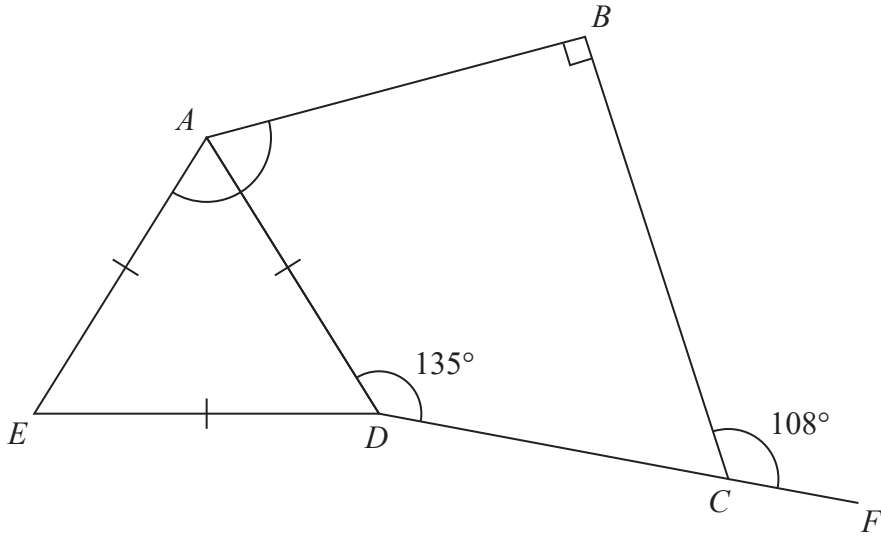

Diagram NOT accurately drawn

ABCD is a quadrilateral.
ADE is an equilateral triangle.
DCF is a straight line.

Work out the size of angle *EAB*.
Give a reason for each stage of your working.

(Total for Question 8 is 5 marks)

DO NOT WRITE IN THIS AREA

DO NOT WRITE IN THIS AREA

DO NOT WRITE IN THIS AREA



- 9 You can use this graph to change between temperatures in degrees Celsius ($^{\circ}\text{C}$) and temperatures in degrees Fahrenheit ($^{\circ}\text{F}$).

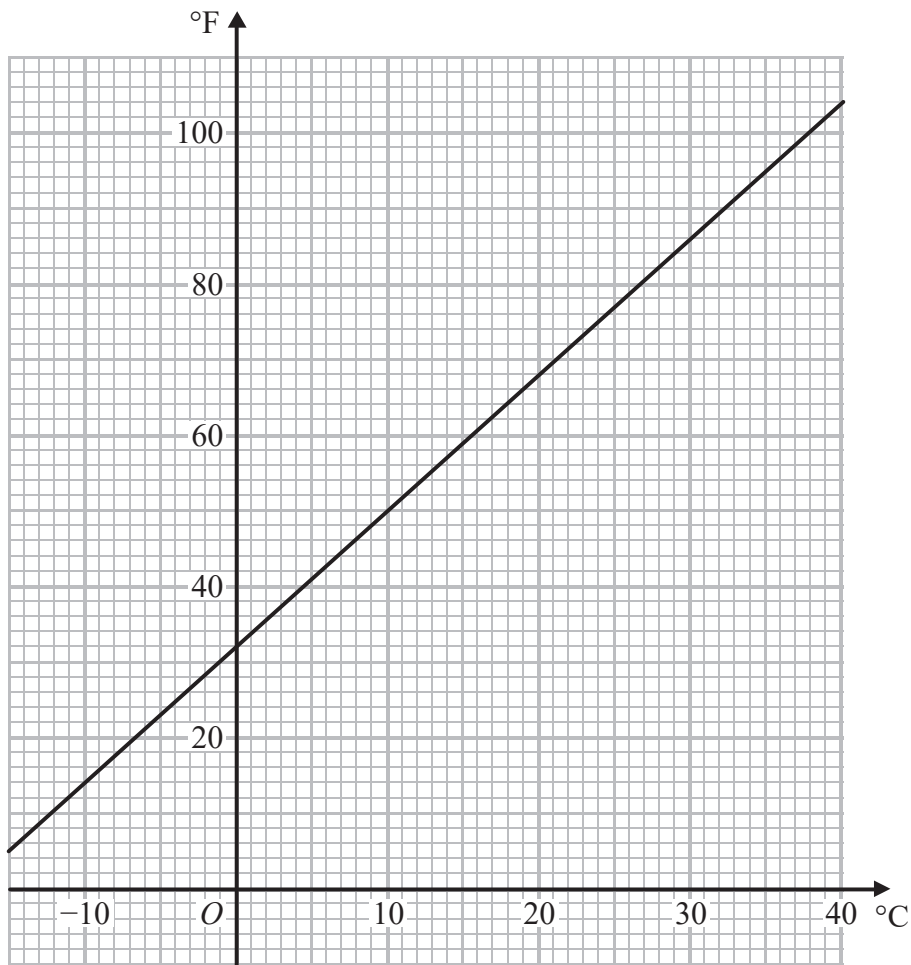

The temperature in Dubai on Monday increased by 20°C from midnight to midday.

- (a) What is this temperature increase in degrees Fahrenheit?

..... $^{\circ}\text{F}$
(2)

Maninder says,

“ 30°C is the same as 86°F , therefore 60°C will be the same as 172°F .”

- (b) Is Maninder correct?
Give a reason for your answer.

.....
(1)

(Total for Question 9 is 3 marks)



DO NOT WRITE IN THIS AREA

DO NOT WRITE IN THIS AREA

DO NOT WRITE IN THIS AREA

10 (a) Find the Lowest Common Multiple (LCM) of 12 and 20

.....
(2)

(b) Find the Highest Common Factor (HCF) of 24 and 56

.....
(2)

(Total for Question 10 is 4 marks)



P 5 4 6 9 2 A 0 1 1 2 4

11

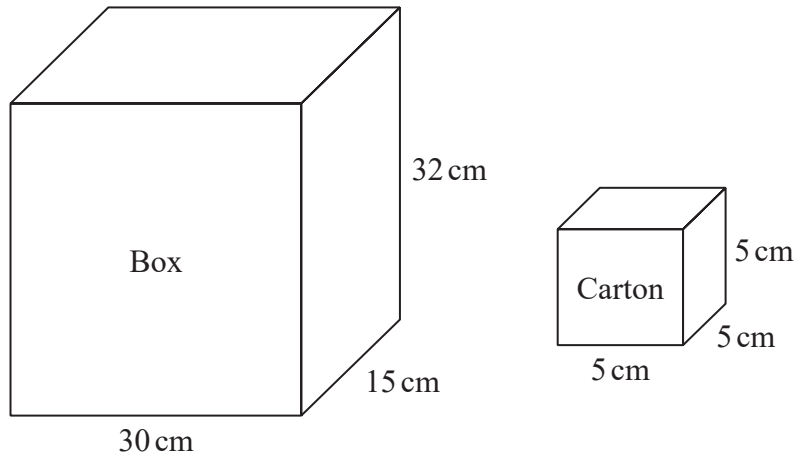

A wooden box measures 30 cm by 15 cm by 32 cm.
The box has a lid.

A carton measures 5 cm by 5 cm by 5 cm.

James has 110 cartons.
He wants to put all these cartons in the box and be able to shut the lid.

Can James put all 110 cartons in the box and shut the lid?
Show your working clearly.

DO NOT WRITE IN THIS AREA

DO NOT WRITE IN THIS AREA

DO NOT WRITE IN THIS AREA

(Total for Question 11 is 3 marks)



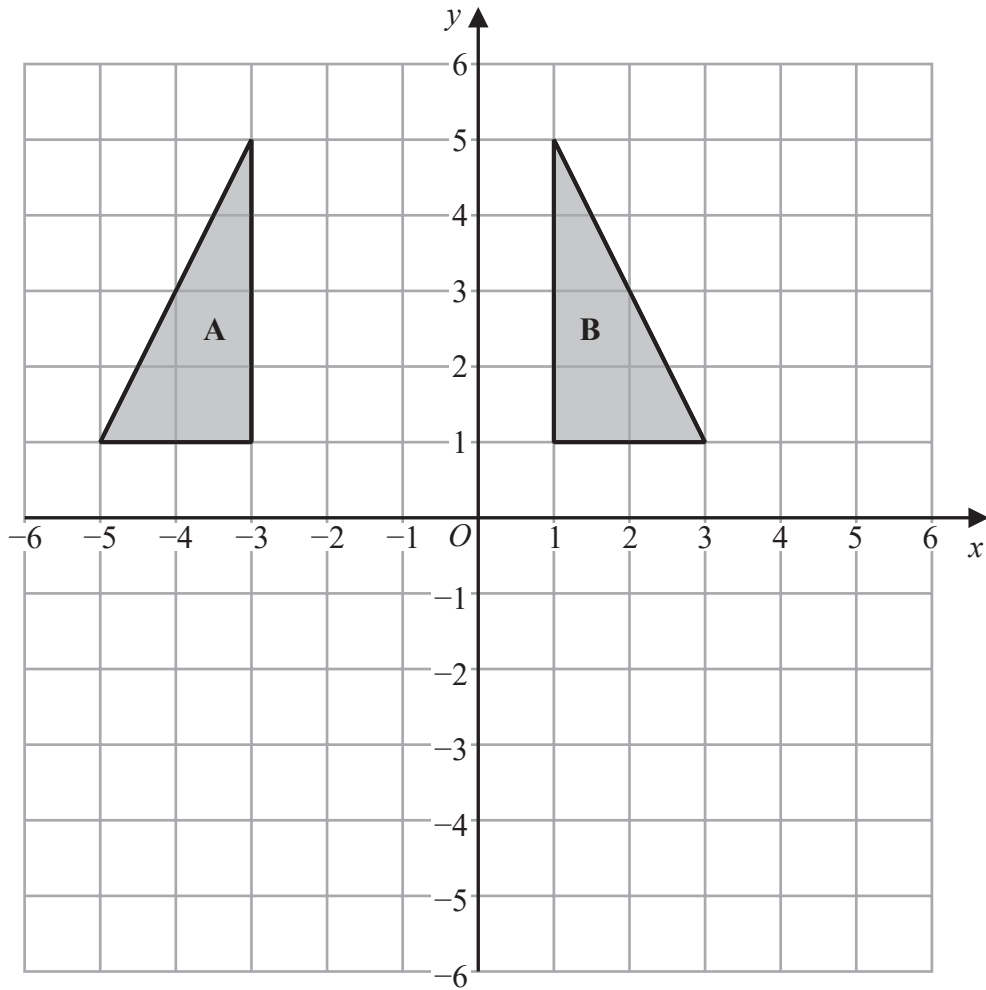

(a) Describe fully the single transformation that maps triangle **A** onto triangle **B**.

(2)

(b) On the grid, translate triangle **B** by the vector $\begin{pmatrix} 2 \\ -6 \end{pmatrix}$
Label your triangle **C**.

(1)

(c) Describe fully the single transformation that maps triangle **C** onto triangle **B**.

(1)

(Total for Question 12 is 4 marks)

DO NOT WRITE IN THIS AREA

DO NOT WRITE IN THIS AREA

DO NOT WRITE IN THIS AREA



13 There are some people in a cinema.

$\frac{3}{5}$ of the people in the cinema are children.

For the children in the cinema,

number of girls : number of boys = 2 : 7

There are 170 girls in the cinema.

Work out the number of adults in the cinema.

DO NOT WRITE IN THIS AREA

DO NOT WRITE IN THIS AREA

DO NOT WRITE IN THIS AREA

(Total for Question 13 is 5 marks)



DO NOT WRITE IN THIS AREA

DO NOT WRITE IN THIS AREA

DO NOT WRITE IN THIS AREA

14 The accurate scale drawing shows the positions of two ships, *L* and *M*.

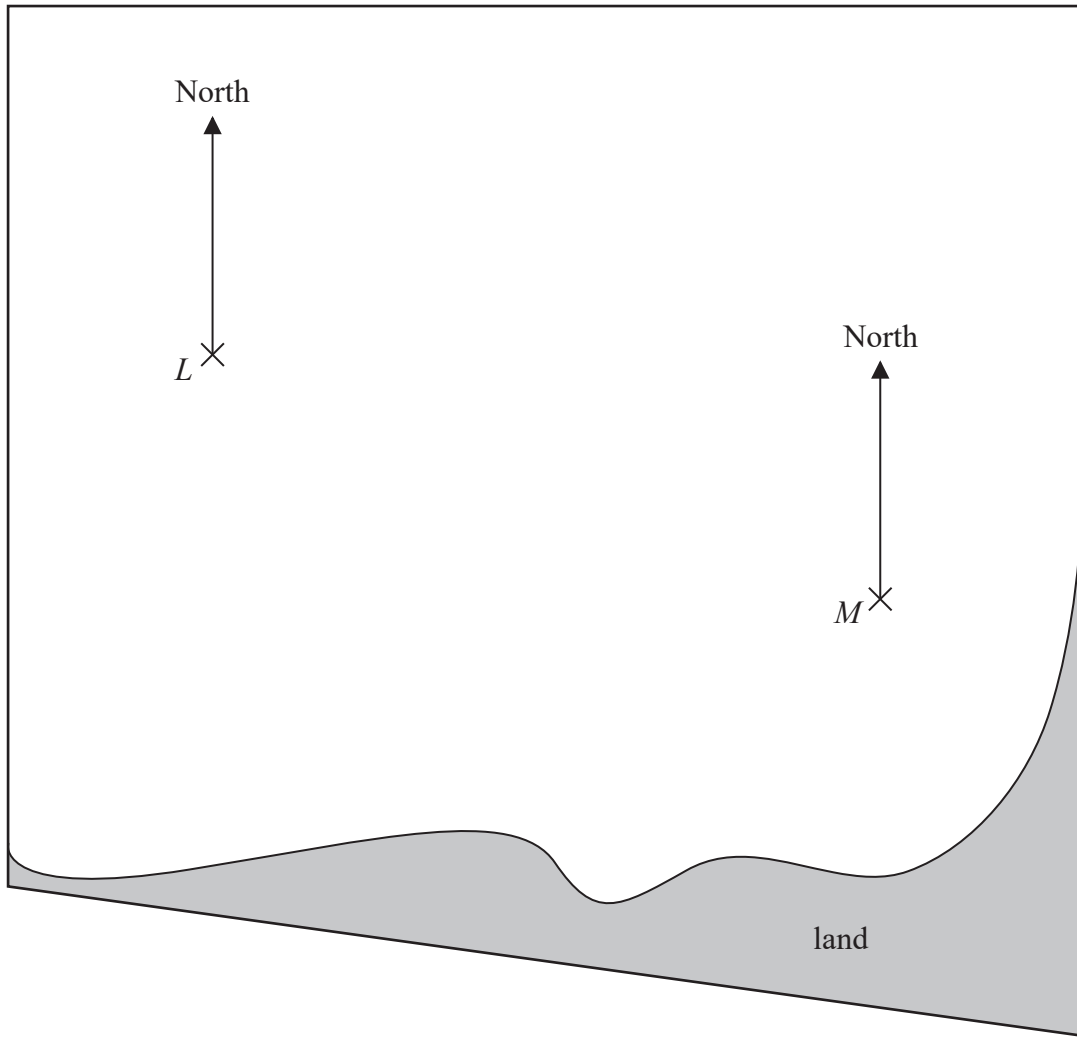

(a) Find the bearing of ship *M* from ship *L*.

.....
(1)

The scale of the drawing is 1 cm to 5 km.

Ship *P* is 40 km from *L* and on a bearing of 240° from *M*.

(b) On the diagram, mark with a cross (X) the position of ship *P*.

(3)

(Total for Question 14 is 4 marks)



15 The table shows information about the weights, in kg, of 40 parcels.

Weight of parcel (p kg)	Frequency
$0 < p \leq 1$	19
$1 < p \leq 2$	12
$2 < p \leq 3$	5
$3 < p \leq 4$	2
$4 < p \leq 5$	2

(a) Write down the modal class.

.....
(1)

(b) Work out an estimate for the mean weight of the parcels.

..... kg
(4)

(Total for Question 15 is 5 marks)



DO NOT WRITE IN THIS AREA

DO NOT WRITE IN THIS AREA

DO NOT WRITE IN THIS AREA

16 (a) Simplify $y^5 \times y^9$

.....
(1)

(b) Simplify $(2m^3)^4$

.....
(2)

(c) Solve $5(x + 3) = 3x - 4$
Show clear algebraic working.

$x =$
(3)

(d) (i) Factorise $x^2 + 2x - 24$

.....
(2)

(ii) Hence, solve $x^2 + 2x - 24 = 0$

.....
(1)

(Total for Question 16 is 9 marks)



17 Here is a Venn diagram.

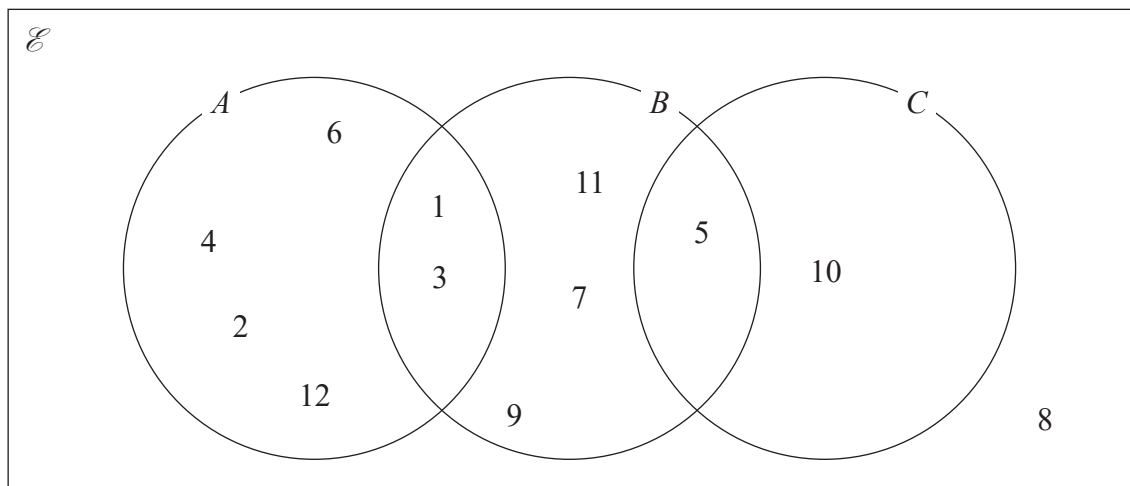

(a) Write down the numbers that are in the set

(i) A

.....

(ii) $B \cup C$

.....

(2)

Brian writes down the statement $A \cap C = \emptyset$

(b) Is Brian's statement correct?

You must give a reason for your answer.

.....

.....

(1)

One of the numbers in the Venn diagram is picked at random.

(c) Find the probability that this number is in set C'

.....

(2)

(Total for Question 17 is 5 marks)



DO NOT WRITE IN THIS AREA

DO NOT WRITE IN THIS AREA

DO NOT WRITE IN THIS AREA

18 (a) Write 8×10^4 as an ordinary number.

.....
(1)

(b) Work out $(3.5 \times 10^5) \div (7 \times 10^8)$
Give your answer in standard form.

.....
(2)

(Total for Question 18 is 3 marks)



19 (a) On the grid, draw the graph of $y = 2x + 3$ for values of x from -2 to 3

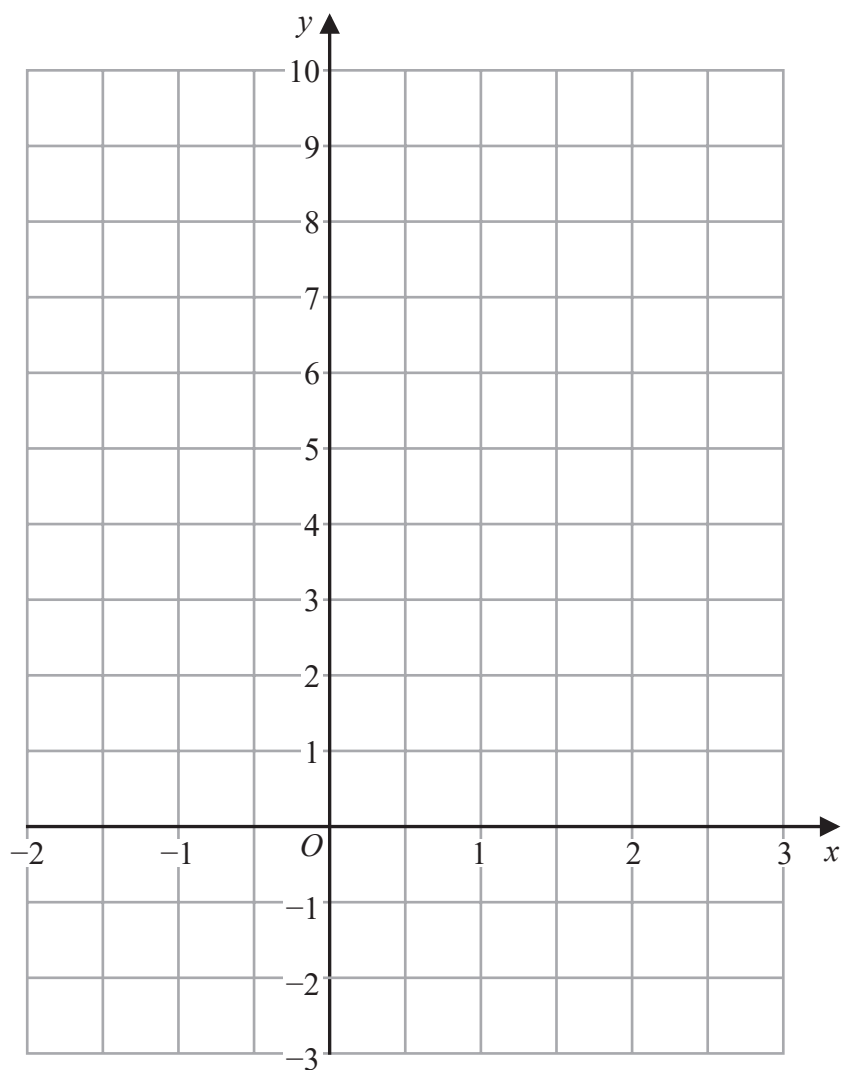

(3)

(b) Show, by shading on the grid, the region that satisfies **all three** of the inequalities

$$x \leq 2$$

$$y \geq 1$$

$$y \leq 2x + 3$$

Label the region **R**.

(2)

(Total for Question 19 is 5 marks)



Diagram **NOT** accurately drawn

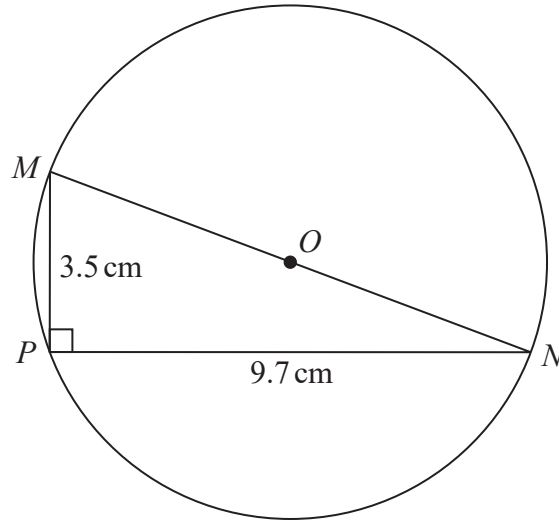

M , N and P are points on a circle, centre O .
 MON is a diameter of the circle.

$MP = 3.5$ cm
 $PN = 9.7$ cm

Angle $MPN = 90^\circ$

Work out the circumference of the circle.
 Give your answer correct to 3 significant figures.

..... cm

(Total for Question 20 is 4 marks)

DO NOT WRITE IN THIS AREA



DO NOT WRITE IN THIS AREA

DO NOT WRITE IN THIS AREA

DO NOT WRITE IN THIS AREA

- 21** Chao bought a boat for HK\$160 000
The value of the boat depreciates by 4% each year.
- (a) Work out the value of the boat at the end of 3 years.
Give your answer correct to the nearest HK\$.

HK\$.....
(3)

Jalina gets a salary increase of 5%
Her salary after the increase is HK\$252 000

- (b) Work out Jalina's salary before the increase.

HK\$.....
(3)

(Total for Question 21 is 6 marks)

TOTAL FOR PAPER IS 100 MARKS



BLANK PAGE



BLANK PAGE

