

Thursday 18 June 2015 – Morning

A2 GCE PHYSICS A

G485/01 Fields, Particles and Frontiers of Physics

Candidates answer on the Question Paper.

OCR supplied materials:

- Data, Formulae and Relationships Booklet (sent with general stationery)

Other materials required:

- Electronic calculator

Duration: 2 hours

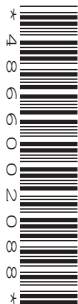

| | | | |
|--------------------|--|-------------------|--|
| Candidate forename | | Candidate surname | |
|--------------------|--|-------------------|--|

| | | | | | | | | | | |
|---------------|--|--|--|--|--|------------------|--|--|--|--|
| Centre number | | | | | | Candidate number | | | | |
|---------------|--|--|--|--|--|------------------|--|--|--|--|

INSTRUCTIONS TO CANDIDATES

- Write your name, centre number and candidate number in the boxes above. Please write clearly and in capital letters.
- Use black ink. HB pencil may be used for graphs and diagrams only.
- Answer **all** the questions.
- Read each question carefully. Make sure you know what you have to do before starting your answer.
- Write your answer to each question in the space provided. If additional space is required, you should use the lined page(s) at the end of this booklet. The question number(s) must be clearly shown.
- Do **not** write in the bar codes.

INFORMATION FOR CANDIDATES

- The number of marks is given in brackets [] at the end of each question or part question.
- The total number of marks for this paper is **100**.
- You may use an electronic calculator.
- You are advised to show all the steps in any calculations.



Where you see this icon you will be awarded marks for the quality of written communication in your answer.

This means for example you should:

- ensure that text is legible and that spelling, punctuation and grammar are accurate so that meaning is clear;
- organise information clearly and coherently, using specialist vocabulary when appropriate.
- This document consists of **28** pages. Any blank pages are indicated.

Answer **all** the questions.

- 1 (a) An electric field always exists around a charged particle.

Explain what is meant by an *electric field*.

.....
..... [1]

- (b) State **one** difference and **one** similarity between the electric field of a point charge and the gravitational field of a point mass.

difference

.....

similarity

..... [2]

- (c) Fig. 1.1 shows the uniform electric field between two vertical parallel plates **A** and **B**.

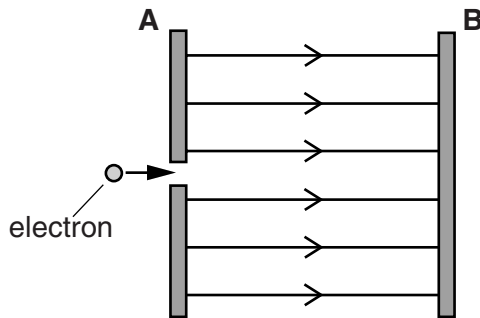

Fig. 1.1

The potential difference between the plates is 6V. An electron of kinetic energy 4eV is fired in a direction parallel to the electric field through a tiny hole in plate **A**.

Describe and explain the subsequent motion of the electron in the space between **A** and **B**. The weight of the electron has negligible effect on its motion between the plates.

.....
.....
.....
.....
.....
.....
.....
..... [3]

- (d) Two different minerals acquire opposite charges when they are crushed into tiny particles. These oppositely charged mineral particles fall from a conveyor belt through the uniform electric field between two vertical parallel plates, as shown in Fig. 1.2.

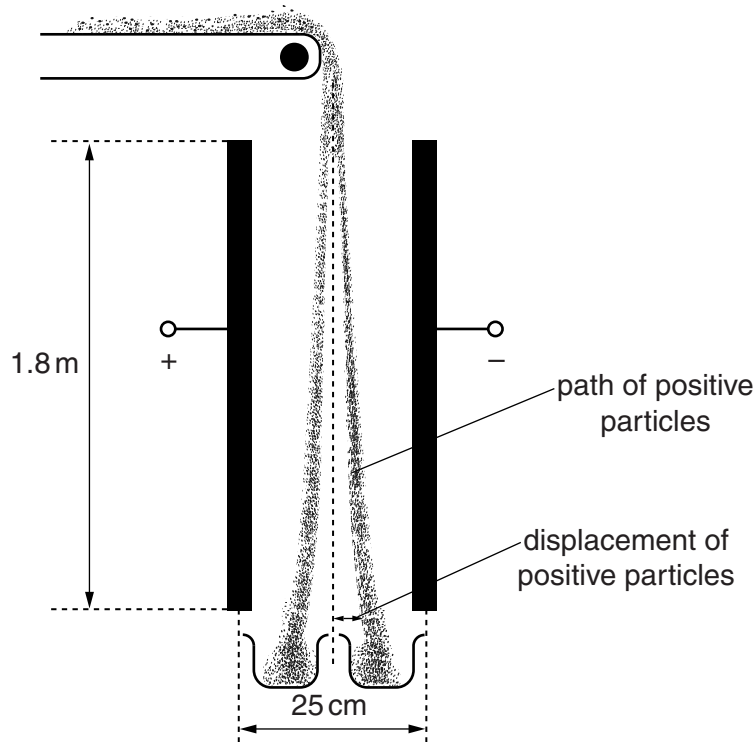

Fig. 1.2

The potential difference across the plates is 60 kV. The separation between the plates is 25 cm and each plate has length 1.8 m. The mineral particles fall through the air between the plates with a terminal velocity of 1.2 m s^{-1} . Each mineral particle has a charge of magnitude $1.5 \times 10^{-13} \text{ C}$ and a mass of $8.0 \times 10^{-7} \text{ kg}$.

- (i) Calculate the horizontal electric force experienced by a positively charged mineral particle as it falls between the plates.

force = N [2]

4

- (ii) Calculate the horizontal displacement of a positively charged mineral particle after a 1.8m fall through the electric field of the plates. Ignore any horizontal drag forces due to air.

displacement = m [3]

- 2 (a) Fig. 2.1 shows a horizontal current-carrying wire placed in a uniform magnetic field.

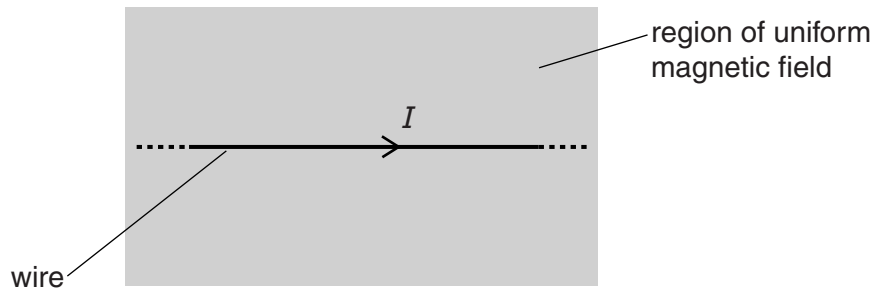

Fig. 2.1

The magnetic field of flux density 0.070T is at right angles to the wire and into the plane of the paper. The weight of a 1.0 cm length of the wire is $6.8 \times 10^{-5}\text{ N}$. The current I in the wire is such that the vertical upward force on the wire due to the magnetic field is equal to the weight of the wire.

- (i) Calculate the current I in the wire.

$$I = \dots\dots\dots \text{ A [2]}$$

- (ii) Suggest why it would be impossible for overhead cables carrying an alternating current to float in the Earth's magnetic field.

.....
 [1]

- (b) A charged particle enters a region of uniform magnetic field. Fig. 2.2 shows the path of this particle.

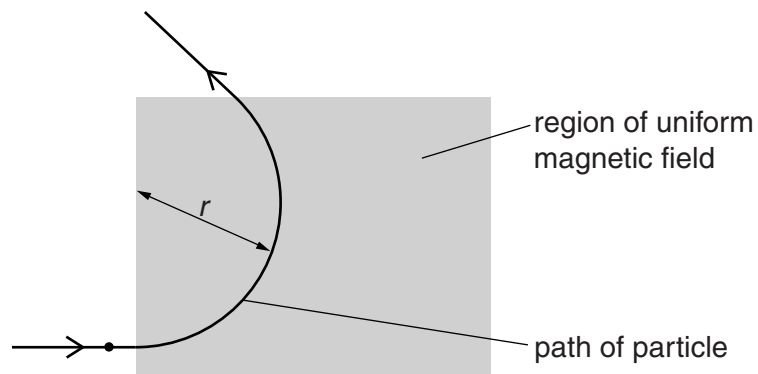

Fig. 2.2

The direction of the field is perpendicular to the plane of the paper. The magnetic field has flux density B . The particle has mass m , charge Q and speed v . The particle travels in a circular arc of radius r in the magnetic field.

- (i) Derive an equation for the radius r in terms of B , m , Q and v .

[2]

- (ii) A thin aluminium plate is now placed in the magnetic field. Fig. 2.3 shows the path of an unknown charged particle.

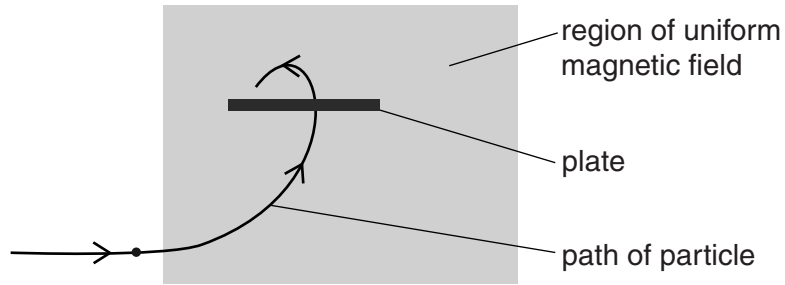

Fig. 2.3

The particle loses some of its kinetic energy as it travels through the plate. The initial radius of the path of the particle before it enters the plate is 4.8 cm. After leaving the plate the final radius of the path of the particle is 1.2 cm.

Calculate the ratio

$$\frac{\text{initial kinetic energy of particle}}{\text{final kinetic energy of particle}}$$

ratio = [2]

3 (a) State, with a reason, whether or not protons and neutrons are fundamental particles.

.....
 [1]

(b) State **two** fundamental particles that can be classified as leptons.

..... [1]

(c) Some fruits, such as bananas, are naturally radioactive because they contain the unstable isotope of potassium-40 ($^{40}_{19}\text{K}$).

(i) The isotope of potassium-40 is a beta-minus emitter.

Complete the following decay equation for $^{40}_{19}\text{K}$.



(ii) Explain why energy is released when a single nucleus of potassium-40 decays.

.....

 [2]

(iii) A banana contains 4.5×10^{-4} kg of potassium. About 0.012% of the mass of potassium in the banana has the unstable isotope of potassium-40. This isotope of potassium-40 has a half-life of 4.2×10^{16} s. The molar mass of potassium-40 is $0.040 \text{ kg mol}^{-1}$.

Calculate the activity from this banana.

activity = Bq [3]

- 4 (a) A charged capacitor is connected across the ends of a negative temperature coefficient (NTC) thermistor kept at a fixed temperature. The capacitor discharges through the thermistor. The potential difference V across the capacitor is maximum at time $t = 0$.

- (i) On the axes of Fig. 4.1, carefully sketch a graph to show how the potential difference V across the capacitor varies with time t . Label this graph **L**.

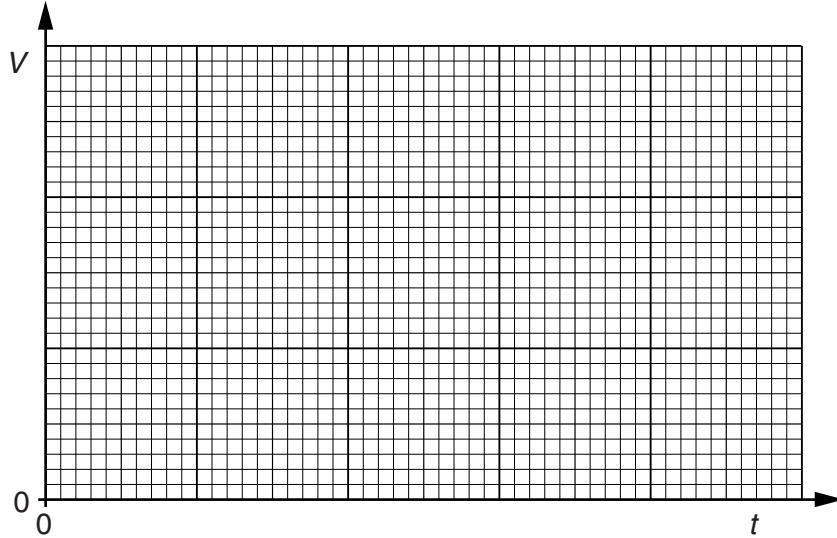

Fig. 4.1

[1]

- (ii) The temperature of the thermistor is increased to a higher fixed value. On Fig. 4.1, sketch another graph to show the variation of V with t when the same charged capacitor is discharged across the ends of the hotter thermistor. Label this graph **H**. [1]

- (iii) Explain how you can show that the graph sketched in (i) has a constant-ratio property (exponential decay).

.....

 [1]

(b) Fig. 4.2 shows an electrical circuit.

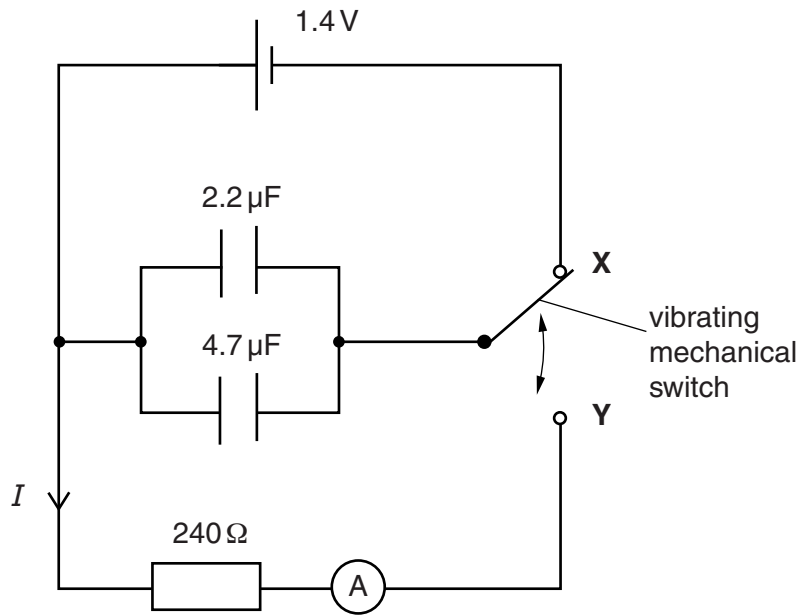

Fig. 4.2

The cell has e.m.f. 1.4V and negligible internal resistance. The values of the capacitors and the resistor are shown in Fig. 4.2. A mechanical switch vibrates between contacts X and Y at a frequency of 120Hz.

(i) Calculate the time constant of the circuit.

time constant = s [1]

(ii) Calculate the value of the average current I in the resistor. Assume that the capacitors are fully discharged between each throw of the switch.

$I =$ A [3]

- (iii) The frequency of vibration of the mechanical switch is doubled. Explain why the average current in the circuit is not doubled.

.....

.....

.....

..... [2]

Question 5 starts on page 12

- 5 (a) Explain how the experiments on the scattering of alpha-particles by a metal foil provided evidence for the nuclear model of the atom.



In your answer, you should make clear how your conclusions link with the observations.

.....
.....
.....
.....
.....
..... [3]

- (b) Fig. 5.1 shows an alpha-particle (4He) of kinetic energy 8.0 MeV moving directly towards a nucleus of aluminium-27 (27Al), initially at rest.

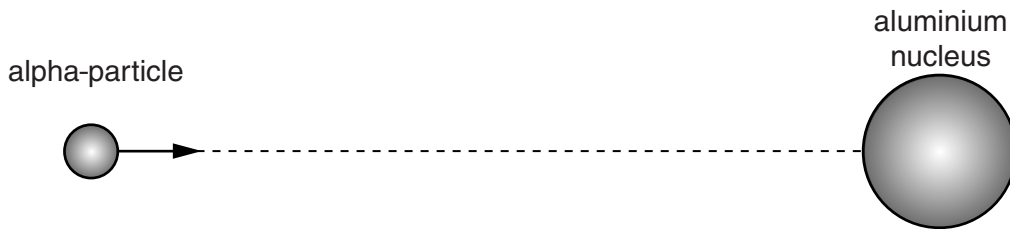

Fig. 5.1

- (i) The alpha-particle comes to rest instantaneously a short distance away from the aluminium nucleus. It then reverses its direction of travel. Describe and explain the motion of the aluminium nucleus at the instant the alpha-particle is at rest.

.....
.....
.....
..... [2]

(ii) Calculate the initial speed of the alpha-particle.

mass of alpha-particle = 6.6×10^{-27} kg

speed = m s^{-1} [2]

(iii) The electric force experienced by the alpha-particle when it is close to the aluminium nucleus is 270 N. Calculate the separation r between the alpha-particle and the aluminium nucleus when the alpha-particle experiences this force.

$r =$ m [3]

(iv) Consider the situation where the alpha-particle travels much closer to the aluminium nucleus than in (b)(iii).

Discuss how the strong nuclear force may affect the resultant force on the alpha-particle.

.....
.....
.....
..... [2]

6 (a) Explain what is meant by the *binding energy* of a nucleus.

.....
 [1]

(b) The fusion of protons occurs in a star when the temperature within the core is greater than about 10^7 K. It takes the fusion of 4 protons to form a helium-4 (${}^4_2\text{He}$) nucleus. In this process, known as the proton–proton cycle, energy is released.

The net energy released in producing a single helium-4 nucleus is 4.53×10^{-12} J.
 Calculate the binding energy per nucleon of the helium-4 nucleus.

binding energy per nucleon = J [1]

(c) The fusion of helium nuclei to make heavier elements occurs in red giants at temperatures above 10^8 K.

Explain why fusion of helium requires higher temperatures than the fusion of hydrogen (protons).

.....

 [2]

(d) Estimate the mean speed of helium nuclei at a temperature of 10^8 K.

mass of helium nucleus = 6.6×10^{-27} kg

speed = m s^{-1} [2]

- 7 (a) A patient has an X-ray scan taken in hospital. The high-energy X-ray photons interact with the atoms inside the body of the patient.

Explain what is meant by a *photon* and state **one** of its main properties.

.....

.....

..... [2]

- (b) An X-ray tube operates using a 150 kV supply. X-ray photons are produced inside the tube when a beam of high-speed electrons accelerated from the cathode collide with the metal anode. About 99% of the total kinetic energy of the electrons at the anode is converted into heat energy which heats the anode. The remaining energy is transformed into the energy of the X-ray photons.

The current in the electron beam between the cathode and the anode is 4.8 mA.

- (i) Show that the number of electrons incident at the anode per second is $3.0 \times 10^{16} \text{ s}^{-1}$.

[1]

- (ii) The anode is made from metal of specific heat capacity $140 \text{ J kg}^{-1} \text{ K}^{-1}$. It has a mass of 8.6 g. The X-ray tube is switched on. Calculate the initial rate of increase of temperature of the anode.

rate of temperature increase = $^{\circ}\text{C s}^{-1}$ [3]

- (iii) A single electron is responsible for producing an X-ray photon. Calculate the shortest wavelength of the X-rays produced from the X-ray tube.

wavelength = m [2]

- (c) An X-ray scan of the heart and its blood vessels shows very poor contrast. Describe and explain a technique that can be used to reveal these blood vessels in an X-ray scan.

.....

.....

.....

..... [2]

8 (a) Fig. 8.1 shows an image of a patient from a gamma camera scan.

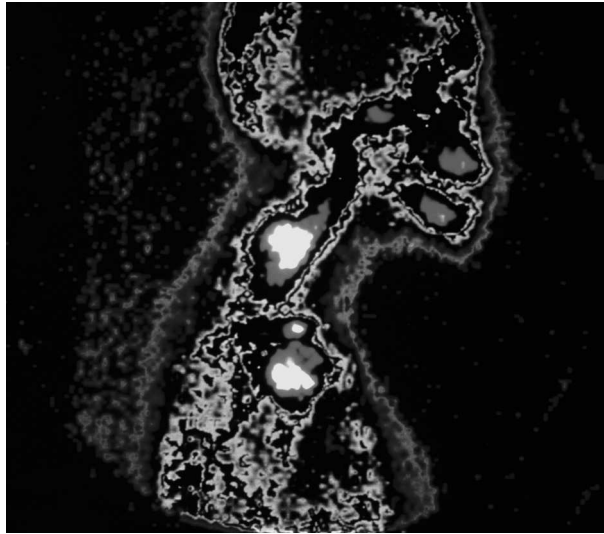

Fig. 8.1

The radioactive gamma-emitting tracer technetium-99m was injected into the patient before the scan. The image shows the distribution and intensity of gamma radiation emitted.

Discuss the advantages of using a gamma-emitting tracer in the patient rather than a beta-emitting tracer.

.....

.....

.....

.....

.....

..... [2]

(b) Many hospitals are equipped with computerised axial tomography (CAT) scanners.

Describe how the components of a CAT scanner are used to produce a three-dimensional image of a patient.

.....
.....
.....
.....
.....
.....
.....
.....
.....
.....
.....
.....
.....
.....
.....
..... [5]

9 (a) Explain what is meant by *Doppler effect*.

.....
..... [1]

(b) Describe how high-frequency ultrasound can be used to determine the speed of blood through the arteries of a patient.



In your answer you should make it clear how the speed is determined.

.....
.....
.....
.....
.....
..... [3]

(c) A patient is scanned using ultrasound of frequency 2.4 MHz. The speed of ultrasound in the blood is 1.57 km s^{-1} . The acoustic impedance of blood is $1.66 \times 10^6 \text{ kg m}^{-2} \text{ s}^{-1}$. Calculate

(i) the density of blood

density = kg m^{-3} [1]

(ii) the wavelength of ultrasound in the blood.

wavelength = m [1]

- (d) Fig. 9.1 shows a beam of ultrasound incident at right angles to the boundary between muscle and bone.

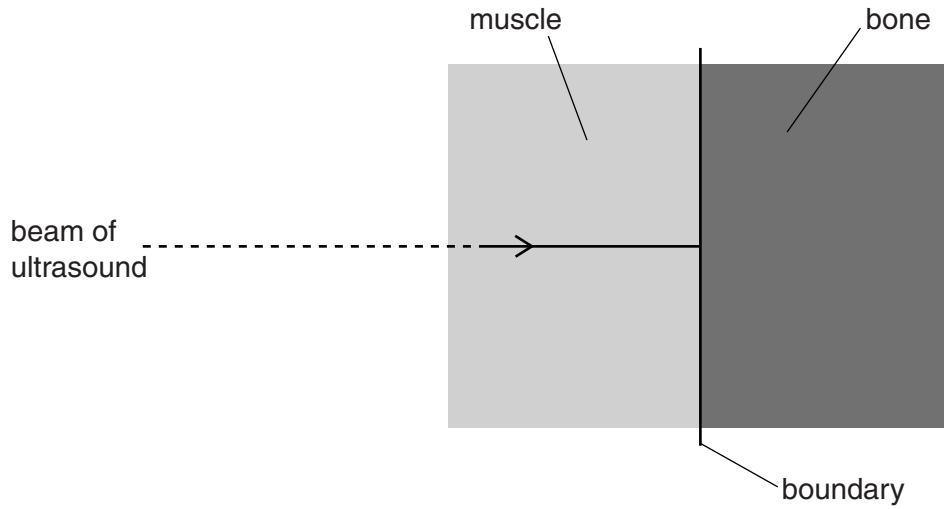

Fig. 9.1

The acoustic impedance of bone is 4 times that of muscle.

Calculate the percentage of ultrasound intensity transmitted into the bone.

intensity = % [3]

- (e) During an ultrasound scan it is important that most of the ultrasound from the transducer is transmitted into the patient. Describe and explain how this is achieved.

.....
.....
.....
..... [2]

21
BLANK PAGE

Question 10 begins on page 22
PLEASE DO NOT WRITE ON THIS PAGE

10 (a) Explain what is meant by a *white dwarf* when describing the evolution of a star.

.....

 [1]

(b) Antares is a red giant and one of the brightest stars in the night sky. The parallax angle for this star is 0.0059 arc seconds.

Calculate its distance in light years from us.
 1 pc = 3.26ly

distance = ly [2]

(c) Sirius-B is a white dwarf. In comparison with Sirius-B, Antares has 12 times greater mass and has 1.1×10^5 times greater radius. The surface temperatures of Sirius-B and Antares are 25000 K and 4300 K respectively.

The intensity I of electromagnetic radiation emitted from the surface of a star is related to its temperature T in kelvin as follows:

$$I \propto T^4.$$

(i) Explain what is meant by *intensity*.

.....
 [1]

(ii) Calculate the ratio

1
$$\frac{\text{mean density of Antares}}{\text{mean density of Sirius-B}}$$

ratio = [2]

2
$$\frac{\text{total power emitted from Antares}}{\text{total power emitted from Sirius-B}}$$

ratio = [3]

11 (a) State Hubble's law.

.....

.....

..... [1]

(b) The redshift of a specific spectral line in the spectrum of a galaxy can be used to determine its recession velocity v . The fractional change z in the wavelength of a spectral line is given by the equation

$$z = \frac{v}{c}$$

where c is the speed of light in a vacuum.

The table of Fig. 11.1 shows data for some of our closest galaxies. The distance of the galaxy from the Earth is d .

| Galaxy | $z / 10^{-3}$ | $v / 10^3 \text{ms}^{-1}$ | $d / 10^{23} \text{m}$ |
|-------------|---------------|---------------------------|------------------------|
| A | 1.12 | 336 | 1.50 |
| B | 1.61 | 483 | 2.14 |
| C | 1.85 | 555 | 2.46 |
| D | 2.26 | 678 | 3.00 |
| Messier 109 | 3.38 | | |

Fig. 11.1

(i) Complete the table by determining v and d for the galaxy Messier 109.

[2]

(ii) Fig. 11.2 shows the data for the first four galaxies plotted on a v against d graph.

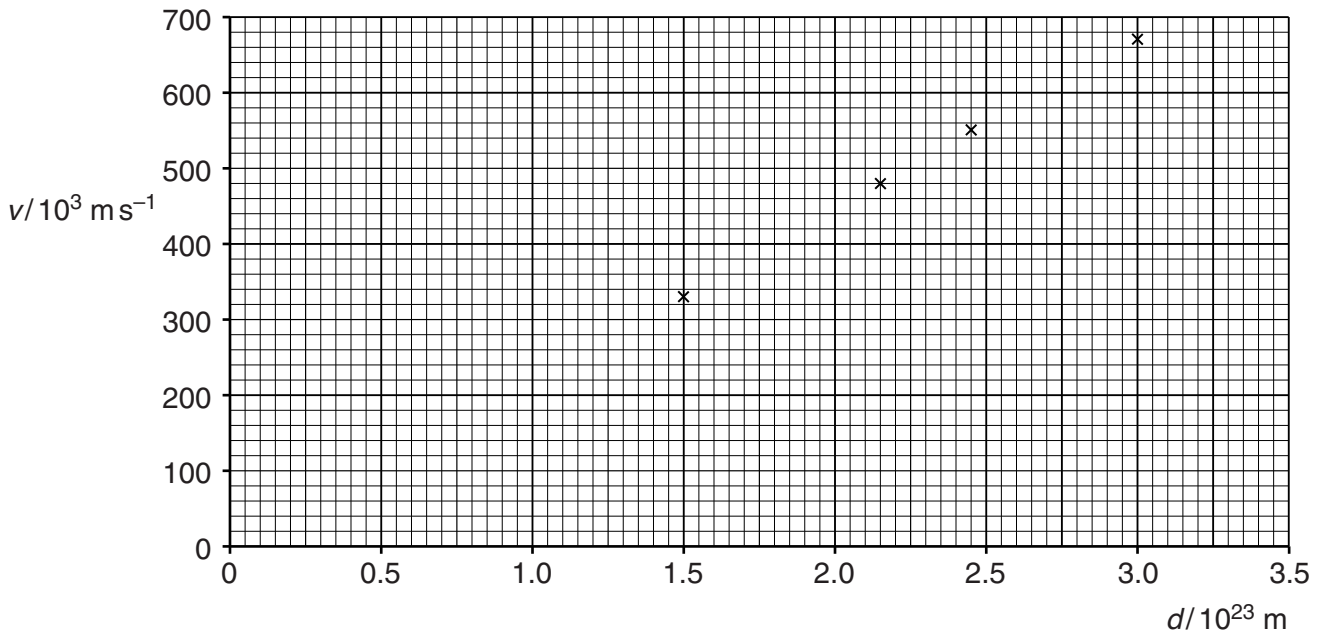

Fig. 11.2

Use Fig. 11.2 to determine the age of the Universe in years.
 $1 \text{ y} = 3.16 \times 10^7 \text{ s}$

age = years [3]

(c) One piece of observational evidence for the big bang is that galaxies are receding from each other.

Explain what is meant by the big bang and suggest **two** other observations that support the big bang model of the Universe.

.....

.....

.....

.....

.....

.....

.....

..... [3]

END OF QUESTION PAPER

ADDITIONAL ANSWER SPACE

If additional answer space is required, you should use the following lined page(s). The question number(s) must be clearly shown in the margins.

A large area of lined paper for writing. It consists of horizontal dotted lines spaced evenly down the page. A vertical solid line runs down the left side of the page, creating a margin. The lines are intended for students to write their answers in.

A large grid of dotted lines for handwriting practice. The grid consists of 24 horizontal rows. The first row is partially cut off at the top. A solid vertical line runs down the left side, starting from the top of the first row and extending to the bottom of the last row. The dotted lines form a series of horizontal bands across the page.

A large area of the page is reserved for writing, featuring a vertical solid line on the left side and horizontal dotted lines extending across the page.



Copyright Information

OCR is committed to seeking permission to reproduce all third-party content that it uses in its assessment materials. OCR has attempted to identify and contact all copyright holders whose work is used in this paper. To avoid the issue of disclosure of answer-related information to candidates, all copyright acknowledgements are reproduced in the OCR Copyright Acknowledgements Booklet. This is produced for each series of examinations and is freely available to download from our public website (www.ocr.org.uk) after the live examination series.

If OCR has unwittingly failed to correctly acknowledge or clear any third-party content in this assessment material, OCR will be happy to correct its mistake at the earliest possible opportunity.

For queries or further information please contact the Copyright Team, First Floor, 9 Hills Road, Cambridge CB2 1GE.

OCR is part of the Cambridge Assessment Group; Cambridge Assessment is the brand name of University of Cambridge Local Examinations Syndicate (UCLES), which is itself a department of the University of Cambridge.