

Write your name here

Surname

Other names

Pearson
Edexcel GCSE

Centre Number

--	--	--	--	--

Candidate Number

--	--	--	--

Mathematics B

Unit 3: Number, Algebra, Geometry 2 (Calculator)

Higher Tier

Monday 10 November 2014 – Morning

Time: 1 hour 45 minutes

Paper Reference

5MB3H/01

You must have: Ruler graduated in centimetres and millimetres, protractor, pair of compasses, pen, HB pencil, eraser, calculator. Tracing paper may be used.

Total Marks



Instructions

- Use **black** ink or ball-point pen.
- **Fill in the boxes** at the top of this page with your name, centre number and candidate number.
- Answer **all** questions.
- Answer the questions in the spaces provided – *there may be more space than you need.*
- **Calculators may be used.**
- If your calculator does not have a π button, take the value of π to be 3.142 unless the question instructs otherwise.

Information

- The total mark for this paper is 80
- The marks for **each** question are shown in brackets – *use this as a guide as to how much time to spend on each question.*
- Questions labelled with an **asterisk** (*) are ones where the quality of your written communication will be assessed.

Advice

- Read each question carefully before you start to answer it.
- Keep an eye on the time.
- Try to answer every question.
- Check your answers if you have time at the end.

Turn over ►

P44593A

©2014 Pearson Education Ltd.

6/7/6/6/



PEARSON

GCSE Mathematics 2MB01

Formulae: Higher Tier

**You must not write on this formulae page.
Anything you write on this formulae page will gain NO credit.**

Volume of prism = area of cross section \times length

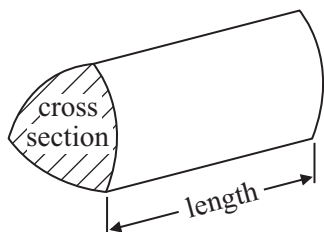

Area of trapezium = $\frac{1}{2} (a + b)h$

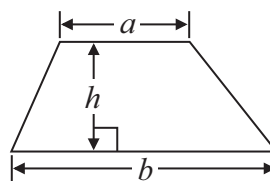

Volume of sphere = $\frac{4}{3} \pi r^3$

Surface area of sphere = $4\pi r^2$

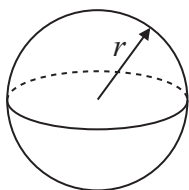

Volume of cone = $\frac{1}{3} \pi r^2 h$

Curved surface area of cone = $\pi r l$

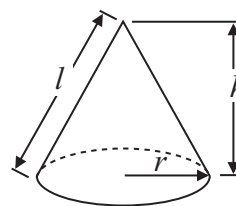

In any triangle ABC

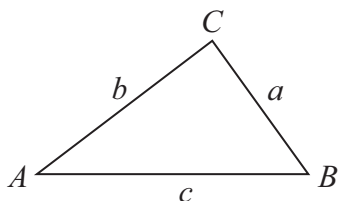

The Quadratic Equation

The solutions of $ax^2 + bx + c = 0$
where $a \neq 0$, are given by

$$x = \frac{-b \pm \sqrt{b^2 - 4ac}}{2a}$$

Sine Rule $\frac{a}{\sin A} = \frac{b}{\sin B} = \frac{c}{\sin C}$

Cosine Rule $a^2 = b^2 + c^2 - 2bc \cos A$

Area of triangle = $\frac{1}{2} ab \sin C$



Answer ALL questions.

Write your answers in the spaces provided.

You must write down all stages in your working.

- 1 (a) Work out the reciprocal of 1.25

.....
(1)

- (b) Work out the value of $\frac{9.6}{\sqrt{5} - 1.7}$

Give your answer correct to 2 decimal places.

.....
(2)

(Total for Question 1 is 3 marks)



*2 Matches are sold in three sizes of box.

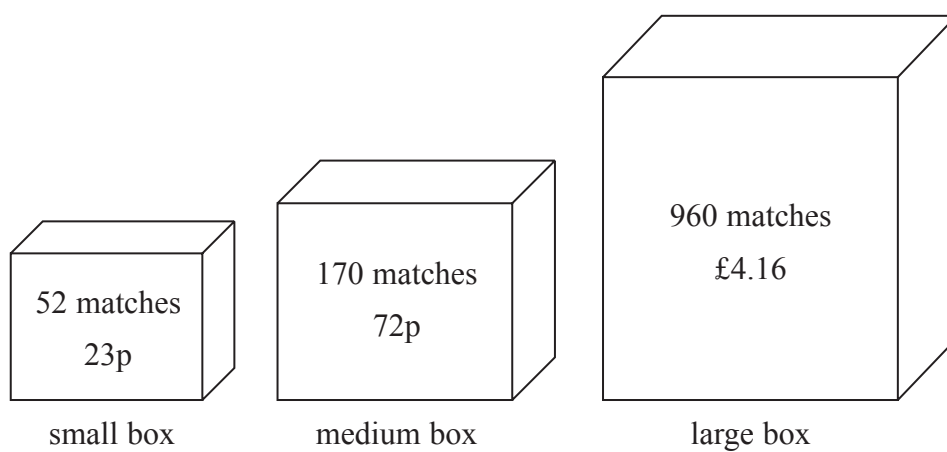

Diagram **NOT** accurately drawn

A small box contains 52 matches and costs 23p.
A medium box contains 170 matches and costs 72p.
A large box contains 960 matches and costs £4.16

Which size of box is the best value for money?
Show how you got your answer.

(Total for Question 2 is 4 marks)



3 The diagram shows two rectangles.

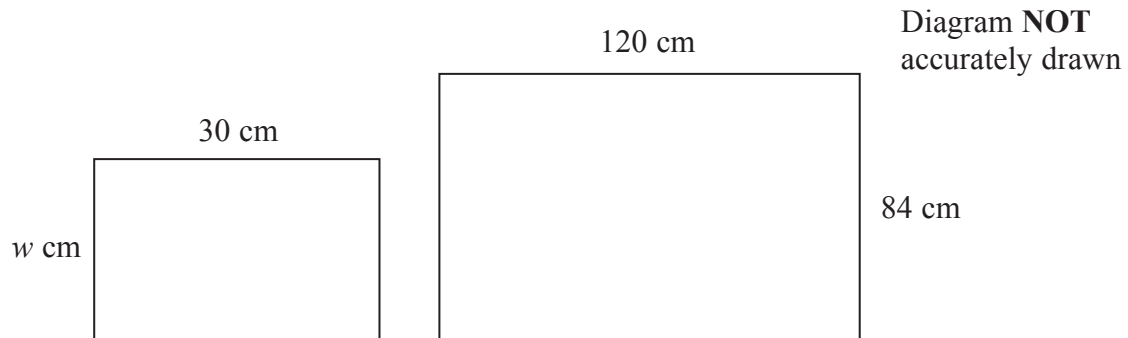

The rectangles are similar.

Work out the value of w .

.....
(Total for Question 3 is 2 marks)



- 4 Tony buys and sells cars.
He has to reach a target of at least 40% profit on each car he sells.

On Monday, Tony buys a car for £1500

On Tuesday, Tony sells the car for £2150

Show that Tony reaches his target for this car.

(Total for Question 4 is 3 marks)



5 The diagram shows a scale drawing of a garden.

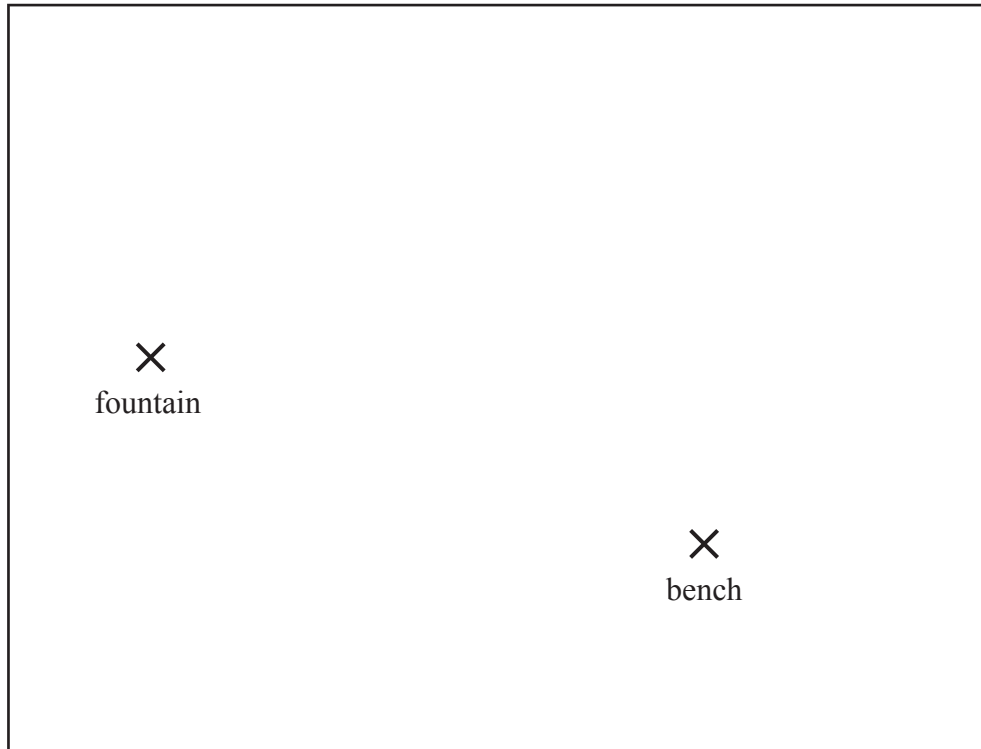

Scale: 1 centimetre represents 2 metres

Haavi is going to plant a tree in the garden.

The tree must be

less than 7 metres from the fountain,
less than 12 metres from the bench.

On the diagram show, by shading, the region in which Haavi can plant the tree.

(Total for Question 5 is 3 marks)



6 The diagram shows a prism.

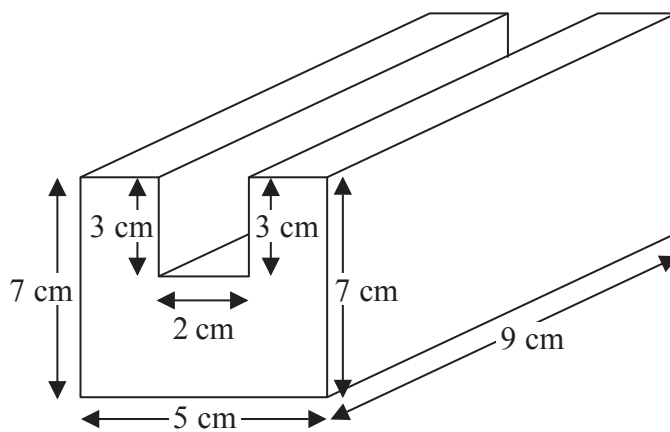

Diagram **NOT** accurately drawn

All the corners are right angles.

Work out the volume of the prism.

(Total for Question 6 is 4 marks)



7

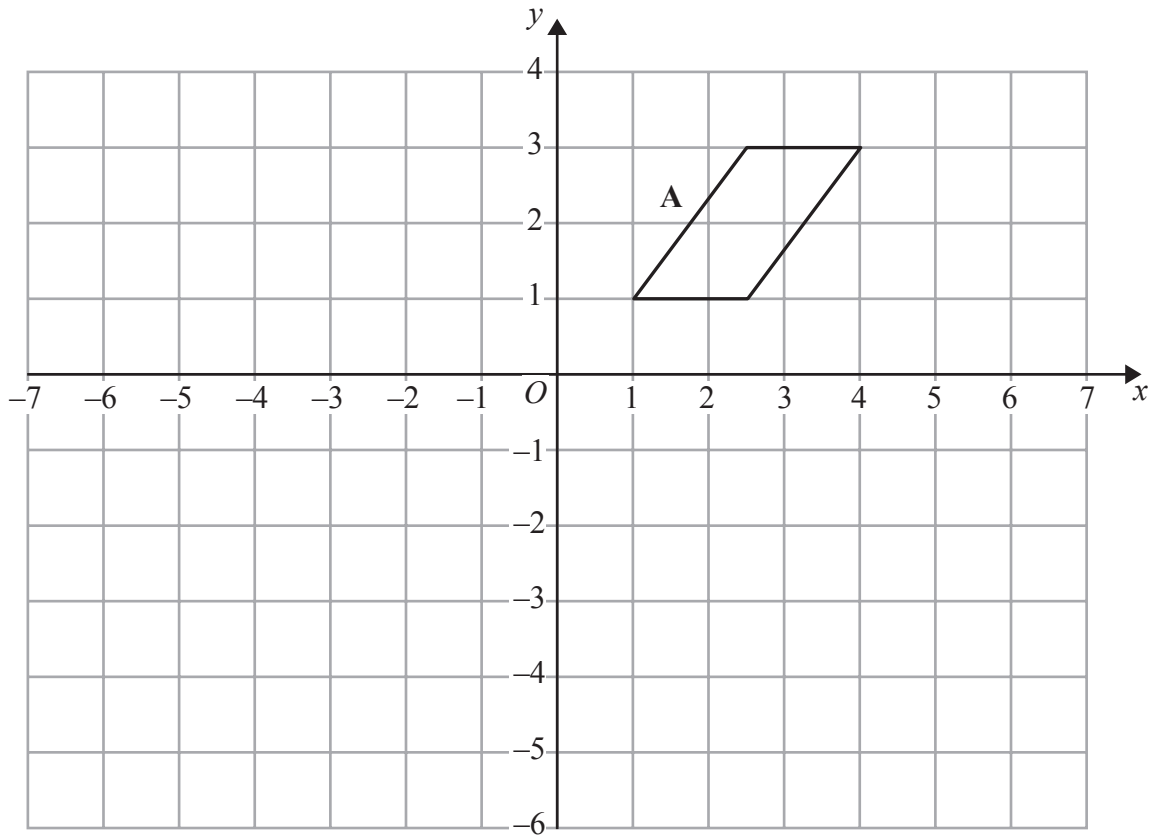

(a) Reflect shape **A** in the line $x = -1$

(2)

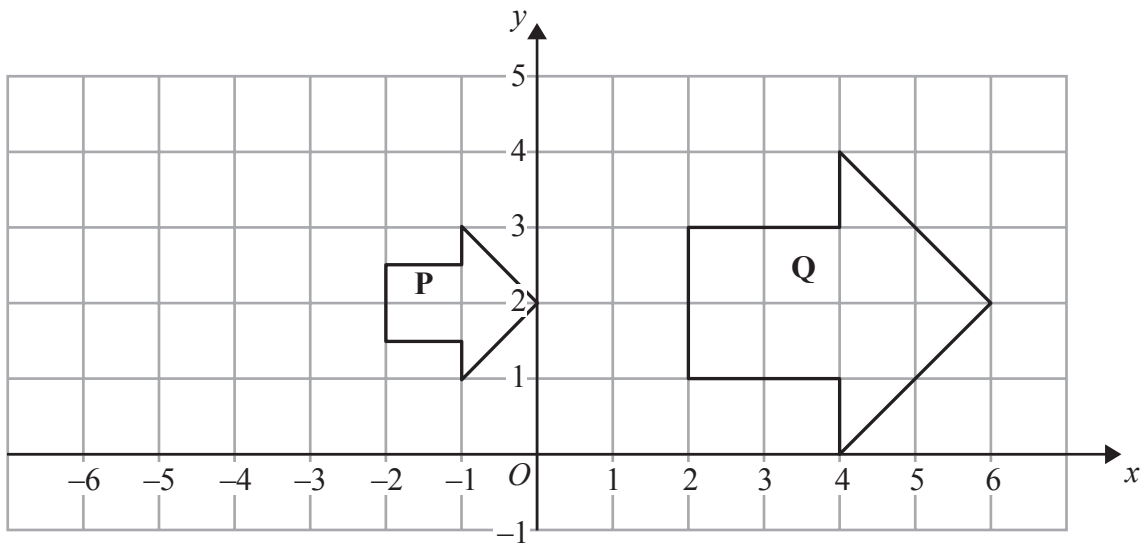

(b) Describe fully the single transformation that maps shape **P** onto shape **Q**.

(3)

(Total for Question 7 is 5 marks)



*8

Nail Company
50 nails
£4.15 plus VAT at 20%

Hammer Company
25 nails
£2.95
Special offer
Buy 100 get 25 free

Barak is going to buy 550 nails from one of these companies.

He wants to buy the nails at the cheaper cost.

Where should he buy the nails, from the Nail Company or from the Hammer Company?

(Total for Question 8 is 5 marks)



9 The equation $x^3 + 27x = 90$
has a solution between 2 and 3

Use a trial and improvement method to find this solution.
Give your answer correct to one decimal place.
You must show all your working.

$x = \dots\dots\dots$

(Total for Question 9 is 4 marks)



10 The diagram shows a trundle wheel.

Diagram **NOT**
accurately drawn

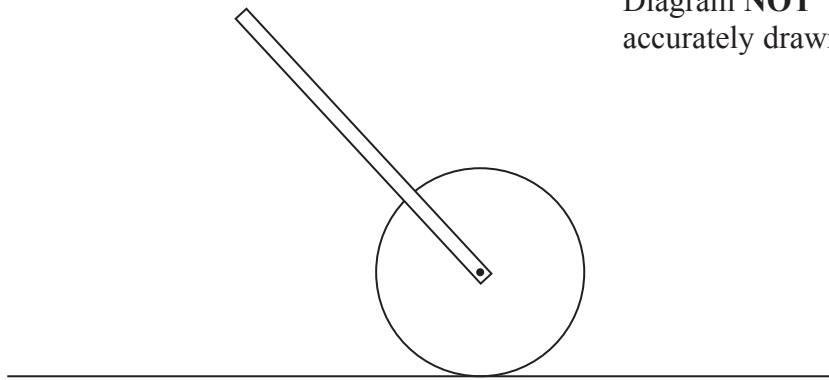

Trundle wheels are used to measure distances along the ground.

The radius of the trundle wheel is 20 cm.

Jim wants to work out the distance between two junctions on a road.
He rolls the trundle wheel between the two junctions.

The trundle wheel rotates exactly 34 times.

Work out the distance between the two junctions.
Give your answer in metres correct to the nearest metre.

.....m

(Total for Question 10 is 3 marks)



11

Diagram **NOT**
accurately drawn

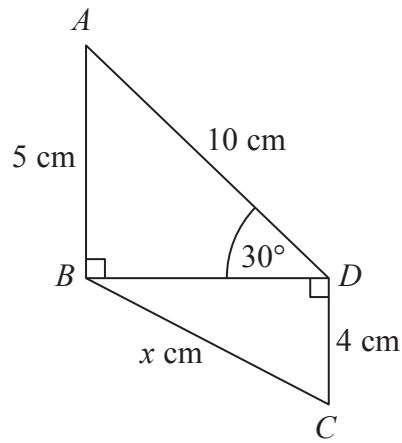

In the diagram,

triangles ABD and BCD are right-angled triangles

$AB = 5$ cm

$AD = 10$ cm

$CD = 4$ cm

Angle $ADB = 30^\circ$

Work out the value of x .

Give your answer correct to 2 decimal places.

.....cm

(Total for Question 11 is 4 marks)



12 $-2 \leq n < 3$

n is an integer.

(a) Write down all the possible values of n .

.....
(2)

(b) Solve $4 - x < 2x - 5$

.....
(2)

(Total for Question 12 is 4 marks)



13 The value of an investment increases exponentially each year with a multiplier of 1.15

How long does it take for the investment to double in value?
Give your answer correct to the nearest whole number of years.

.....years

(Total for Question 13 is 2 marks)



14 (a) Solve $3x^2 = 147$

$$x = \dots\dots\dots$$

(2)

(b) Solve $\frac{y-1}{2} + \frac{y+1}{3} = 15$

$$y = \dots\dots\dots$$

(3)

(Total for Question 14 is 5 marks)



15 (a) Write 450 000 in standard form.

.....
(1)

(b) Write 3.2×10^{-4} as an ordinary number.

.....
(1)

(c) Work out $\sqrt[3]{6.4 \times 10^{10}}$

.....
(1)

(Total for Question 15 is 3 marks)



16 Make q the subject of the formula $r = \frac{2q - 4}{3}$

.....
(Total for Question 16 is 3 marks)



17 On the grid, draw the graph of $y = \frac{1}{x}$ for values of x from 1 to 7

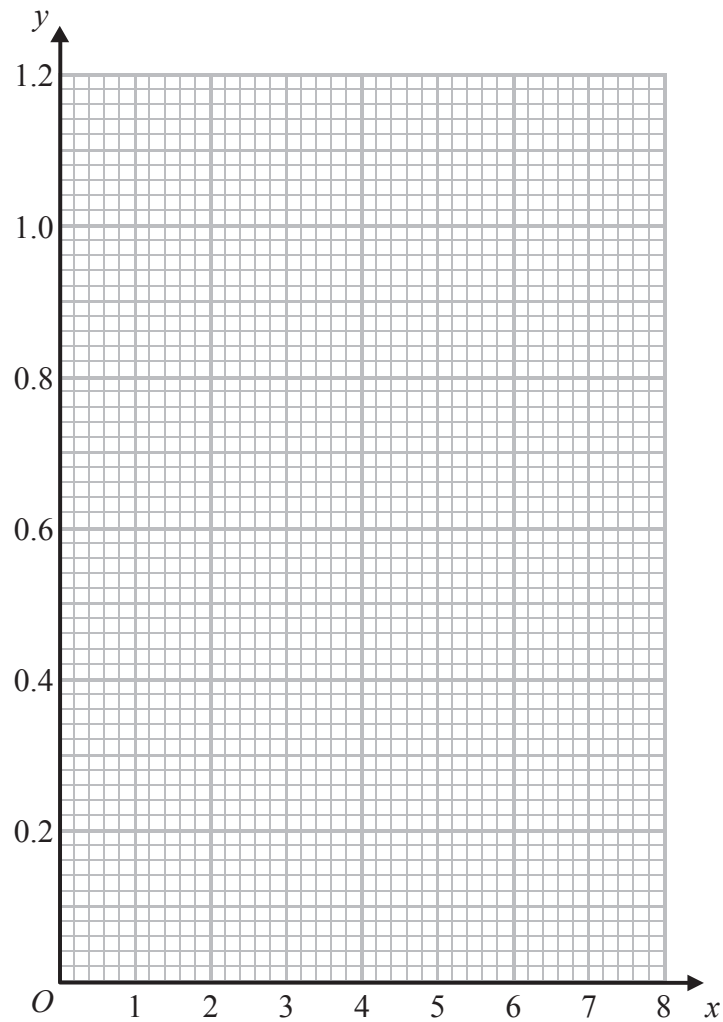

(Total for Question 17 is 3 marks)



18 Solve $2x^2 + 4x - 5 = 0$

Give your solutions correct to 2 decimal places.

.....
(Total for Question 18 is 3 marks)



***19** The Singh family and the Peterson family go to the cinema.

The Singh family buy 2 adult tickets and 3 child tickets.
They pay £28.20 for the tickets.

The Peterson family buy 3 adult tickets and 5 child tickets.
They pay £44.75 for the tickets.

Find the cost of each adult ticket and each child ticket.

(Total for Question 19 is 5 marks)



20 The volume of a sphere is 70 cm^3 correct to the nearest cm^3 .

Calculate the upper bound for the surface area of the sphere.

Give your answer correct to 1 decimal place.

You must show all your working.

..... cm^2

(Total for Question 20 is 4 marks)



21 The diagram shows a regular hexagon $OABCDE$.

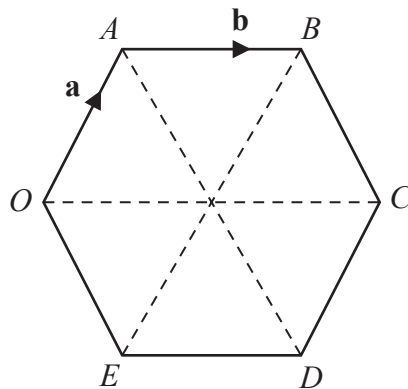

Diagram **NOT** accurately drawn

$$\vec{OA} = \mathbf{a}$$

$$\vec{AB} = \mathbf{b}$$

M is the midpoint of OE .

N is the midpoint of AB .

(a) Find \vec{MN} in terms of \mathbf{a} and/or \mathbf{b} .

$$\vec{MN} = \dots\dots\dots \quad (3)$$

(b) Describe fully what your answer to part (a) shows about the lines OA and MN .

.....
 (2)

(Total for Question 21 is 5 marks)



22 Here is the graph of $y = f(x)$.

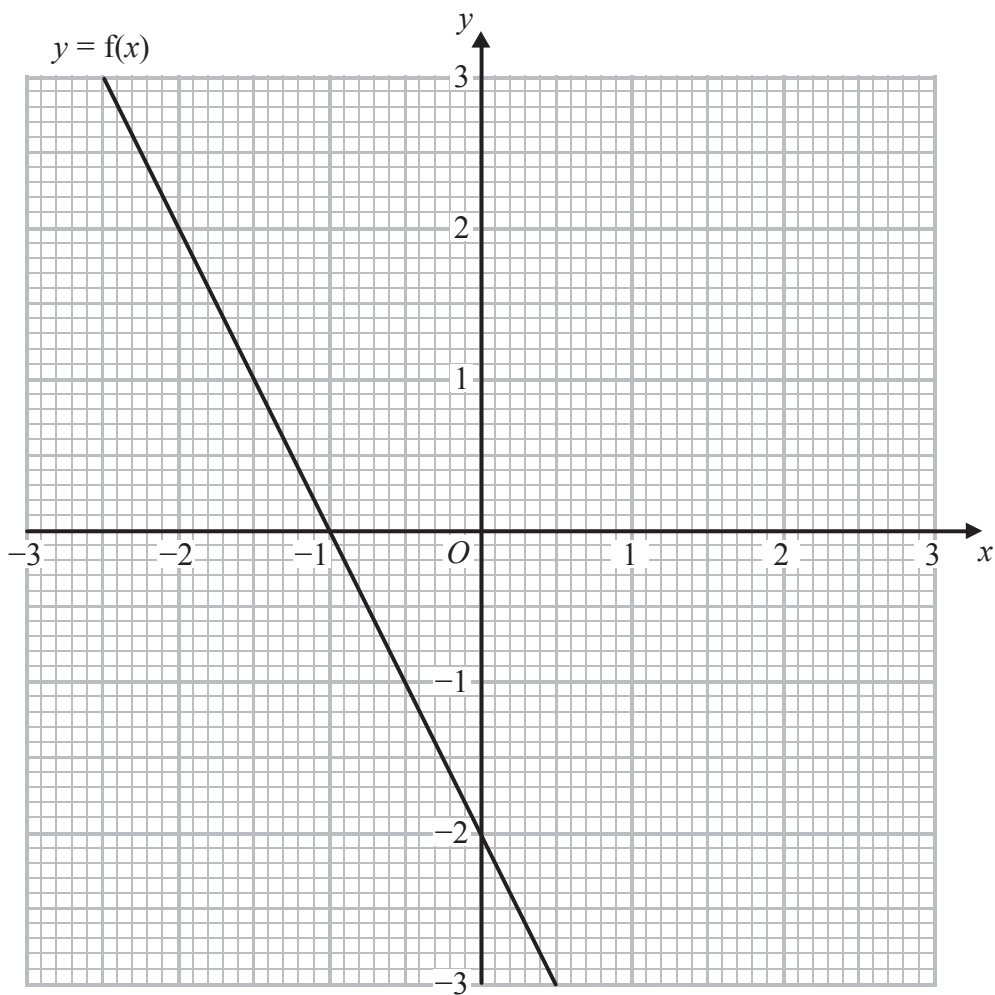

(a) Write down the coordinates of the point where the graph of $y = \frac{1}{2}f(x)$ meets the y -axis.

(.....,)
(1)

(b) On the grid, draw the graph of $y = f(x - 1)$.

(2)

(Total for Question 22 is 3 marks)

TOTAL FOR PAPER IS 80 MARKS

