

Centre Number						Candidate Number				
Surname										
Other Names										
Candidate Signature										

For Examiner's Use	
Examiner's Initials	
Question	Mark
1	
2	
3	
4	
5	
6	
7	
8	
9	
10	
TOTAL	



General Certificate of Education
Advanced Subsidiary Examination
June 2010

Physics (B): Physics in Context PHYB2

Unit 2 Physics Keeps Us Going

Module 1 Moving People, People Moving

Module 2 Energy and the Environment

Wednesday 9 June 2010 9.00 am to 10.15 am

For this paper you must have:

- a pencil and a ruler
- a calculator
- a Data and Formulae Booklet.

Time allowed

- 1 hour 15 minutes

Instructions

- Use black ink or black ball-point pen. Use pencil only for drawing.
- Fill in the boxes at the top of this page.
- Answer **all** questions.
- You must answer the questions in the spaces provided. Do not write outside the box around each page or on blank pages.
- Do all rough work in this book. Cross through any work you do not want to be marked.
- Show all your working.

Information

- The marks for questions are shown in brackets.
- The maximum mark for this paper is 70.
- You are expected to use a calculator where appropriate.
- A *Data and Formulae Booklet* is provided as a loose insert.
- You will be marked on your ability to:
 - use good English
 - organise information clearly
 - use specialist vocabulary where appropriate.

Advice

- You are advised to spend about 20 minutes on **Section A** and about 55 minutes on **Section B**.



JUN10PHYB201

Section A

Answer **all** questions in this section.

There are 20 marks in this section.

1 **Figure 1** shows a stationary gymnast suspended by his arms at the end of two ropes.

Figure 1

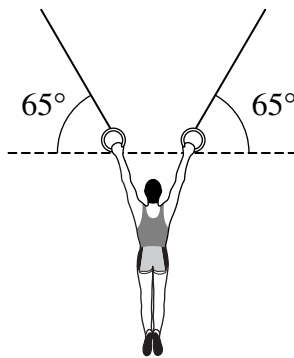

The tension in each rope is $4.1 \times 10^2 \text{ N}$. The angle between each of the ropes and the horizontal is 65° .

Calculate the weight of the gymnast.

Give your answer to an appropriate number of significant figures.

.....
.....
.....
.....

weight of gymnast N
(3 marks)



2 When a 100 W tungsten filament lamp is operating, 3.0% of the input electrical energy is converted into light.

An 18 W compact fluorescent lamp (CFL) emits the same light power output as the filament lamp.

2 (a) Calculate the efficiency of the CFL lamp.

.....
.....
.....
.....

efficiency
(2 marks)

2 (b) The CFL lamp is much more efficient than the tungsten filament lamp. Explain why.

.....
.....
.....
.....

(2 marks)

Turn over for the next question

Turn over ►



3 **Figure 2** shows the graph of the relative intensity I_r against wavelength λ for the Sun.

Figure 2

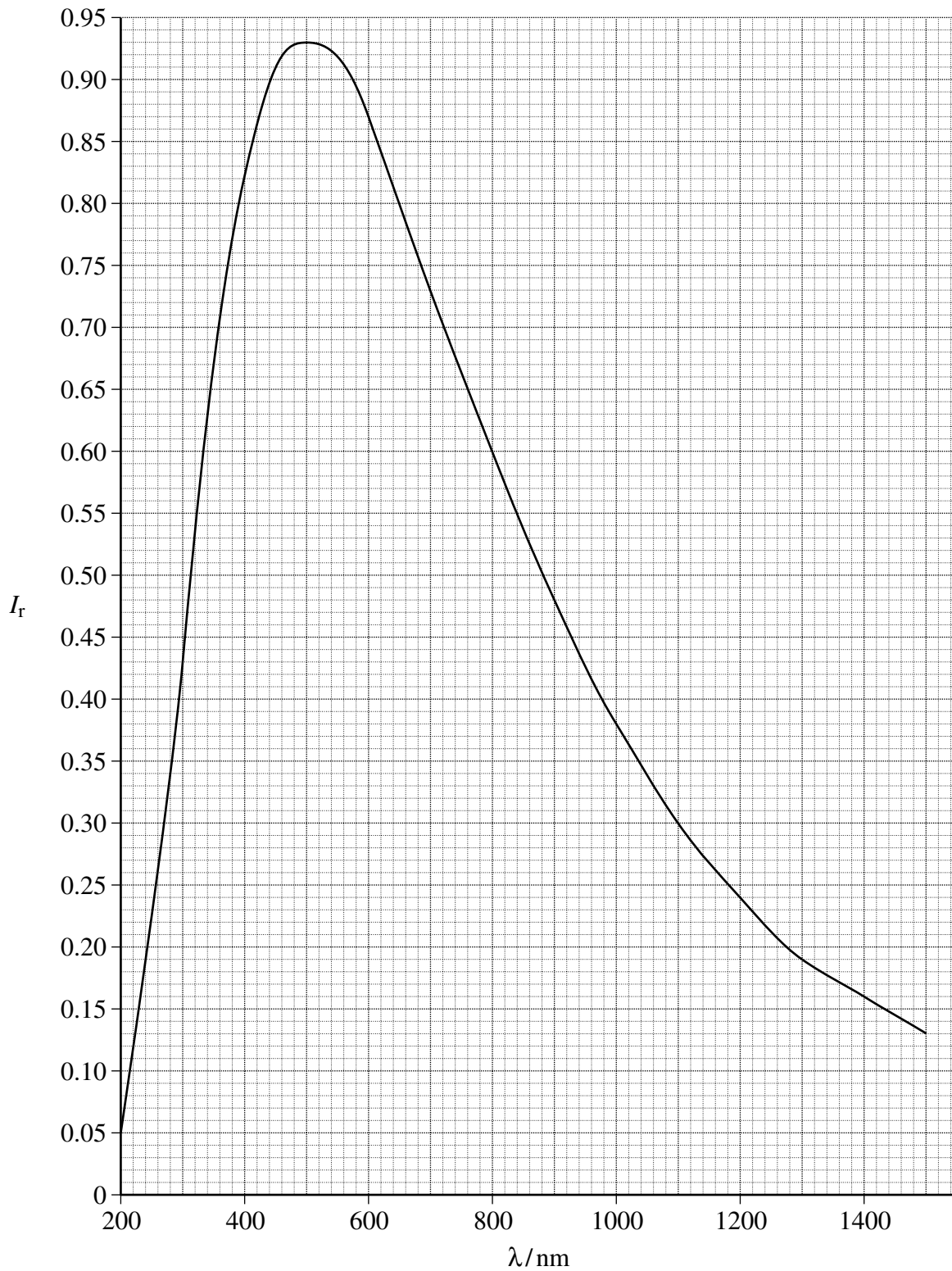

3 (a) State the region of the electromagnetic spectrum in which the peak of the graph of intensity I_r against λ is located.

.....
(1 mark)

3 (b) Using data from **Figure 2**, show that the surface temperature of the Sun is approximately 6000 K.

.....
.....
.....
.....
.....
.....
.....
(3 marks)

Turn over for the next question

Turn over ►



4 A mountain walker of weight 750 N climbs a height of 300 m in 40 minutes.

4 (a) Calculate the average power required due to the gravitational force on the walker during the climb.

.....
.....
.....
.....

average power W
(3 marks)

4 (b) The walker uses a spring loaded walking pole that changes in length by 15 mm when the full weight of the walker is applied to it.

Calculate the stiffness of the spring in the pole.
Give an appropriate unit for your answer.

.....
.....
.....
.....

spring stiffness
unit
(3 marks)



5 A householder removes part of an external wall to create a doorway. He fits a wooden door of dimensions 2.2 m by 1.2 m. The temperature of the air inside the house is 15 K higher than that of the air outside.

Calculate the change in energy loss per second due to this temperature difference as a result of replacing part of the wall with the door.

$$U\text{-value for wall} = 0.60 \text{ W m}^{-2} \text{ K}^{-1}$$

$$U\text{-value for wooden door} = 2.4 \text{ W m}^{-2} \text{ K}^{-1}$$

.....

.....

.....

.....

change in loss of energy per second J s^{-1}
(3 marks)

20

Turn over for the next question

Turn over ►



Section B

Answer **all** questions in this section.

There are 50 marks in this section.

6 **Figure 3** shows a pole-vaulter during a pole-vault.

Figure 3

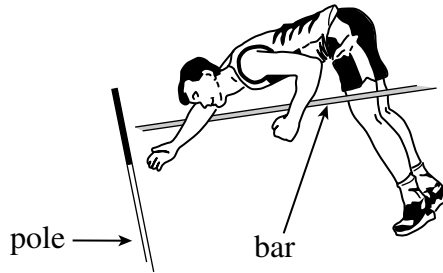

The pole-vaulter is 1.8 m tall and can reach a maximum sprint speed of 8.4 m s^{-1} just before take-off. The mass of the pole-vaulter is 72 kg.

6 (a) (i) Calculate the maximum change in the height of the centre of mass of the pole-vaulter. Assume that the pole-vaulter uses only the kinetic energy he acquires during the sprint.

.....

.....

.....

.....

.....

.....

.....

maximum height change m
(3 marks)



6 (a) (ii) The pole-vaulter's centre of mass is halfway down his body. His centre of mass reaches the same height as the bar.
Calculate the height of the bar above the ground.

.....
.....
.....
.....

height of bar m
(2 marks)

6 (b) (i) Not all of the pole-vaulter's kinetic energy is converted into gravitational potential energy in the pole-vault.

Describe why it is not possible to convert all of his kinetic energy into gravitational potential energy when clearing the bar.

.....
.....
.....
.....
.....
.....
.....
.....
.....
.....

(3 marks)

Question 6 continues on the next page

Turn over ►



6 (b) (ii) The pole-vaulter can clear a higher bar than that calculated in part (a)(ii). This can be done without increasing his maximum sprint speed or changing the equipment used. Explain how this extra height may be achieved.

.....

.....

.....

.....

.....

.....

.....

.....

.....

.....

(3 marks)

11



Turn over for the next question

**DO NOT WRITE ON THIS PAGE
ANSWER IN THE SPACES PROVIDED**

Turn over ►



7 A very high resistance voltmeter reads 15.0 V when it is connected across the terminals of a power supply.

7 (a) Explain why the reading on the voltmeter is equal to the emf of the power supply.

.....
.....
.....
.....
.....
.....

(3 marks)

7 (b) A resistor of value $470\ \Omega$ is connected across the terminals of the power supply in parallel with the voltmeter, as shown in **Figure 4**. The voltmeter reads 14.5 V.

Figure 4

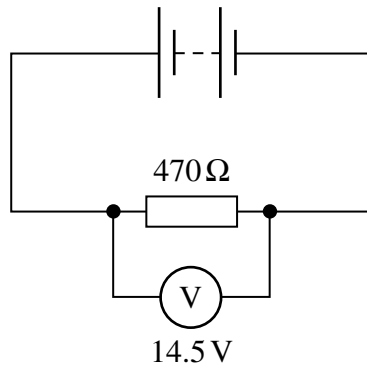

7 (b) (i) Calculate the current in the $470\ \Omega$ resistor.

.....
.....
.....
.....

current A
(2 marks)



7 (b) (ii) Calculate the internal resistance of the power supply.

.....

.....

.....

.....

.....

.....

internal resistance Ω
(3 marks)

8

Turn over for the next question

Turn over ►



- 8 **Figure 5** shows an electrical circuit that contains a $4.0\ \Omega$ resistor, a $0 - 8.0\ \Omega$ variable resistor and a $12\ \text{V}$ power supply with negligible internal resistance.

Figure 5

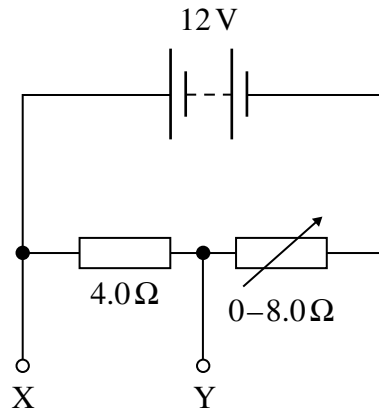

- 8 (a) State the name given to this type of circuit.

.....
(1 mark)

- 8 (b) Calculate the minimum and maximum potential differences that can be obtained across XY. State the corresponding values of the resistance of the variable resistor.

.....
.....
.....
.....
.....
.....

minimum pd V when the resistance of the variable resistor is Ω
maximum pd V when the resistance of the variable resistor is Ω
(4 marks)



8 (c) (i) Complete the circuit diagram to show how a potentiometer (variable resistor) can be connected so that the relative loudness of the sound from two loudspeakers can be adjusted.

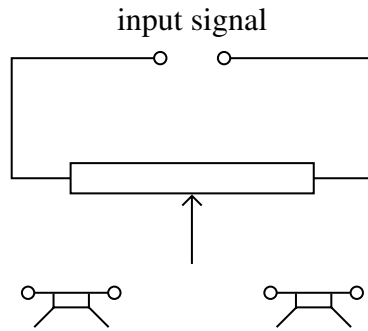

(1 mark)

8 (c) (ii) Explain the advantage of using a potentiometer over the two-resistor arrangement in **Figure 6** for this purpose.

Figure 6

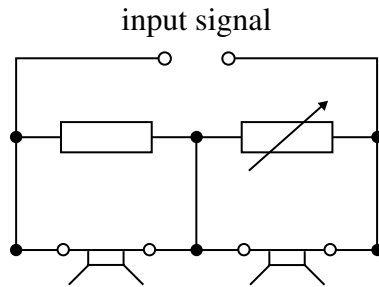

.....

.....

.....

.....

.....

(2 marks)

8

Turn over ►



- 9 **Figure 7** shows data for a photovoltaic cell when the load resistance is varied. The intensity of the energy from the Sun incident on the surface of the photovoltaic cell is constant.

Figure 7

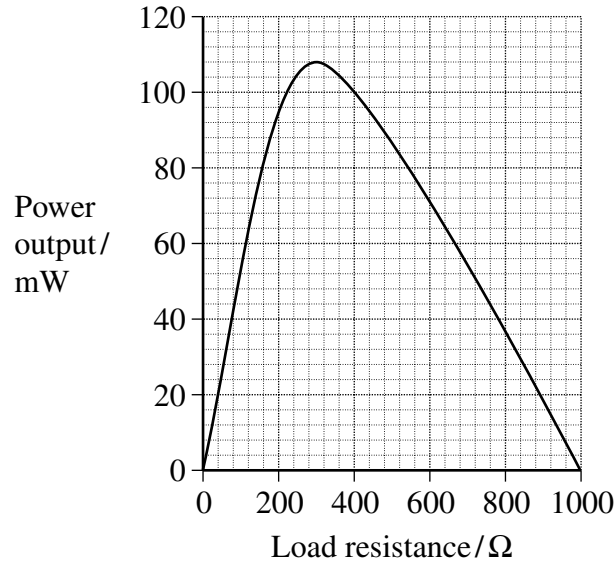

- 9 (a) Using data from **Figure 7**, calculate the current in the load at the peak power.

.....

.....

.....

.....

current A
(3 marks)



9 (b) The active area of the photovoltaic cell has dimensions 60 mm × 60 mm. The intensity of the Sun’s radiation incident on the photovoltaic cell is 730 W m⁻².

When the cell delivers its peak power, calculate

$$\frac{\textit{electrical energy delivered by the cell}}{\textit{energy arriving at the cell from the Sun}}$$

.....
.....
.....
.....
.....

answer
(4 marks)

9 (c) The measurements of the data in **Figure 7** were carried out at noon with the photovoltaic cell in a fixed position.

State **two** reasons why the cell will yield lower peak values at other times of day.

reason 1
.....
.....

reason 2
.....
.....

(2 marks)

9

Turn over ►



10 **Figure 8** shows a car that travels down a hill of constant slope with the engine turned off. The slope is inclined at 9° to the horizontal.

Figure 8

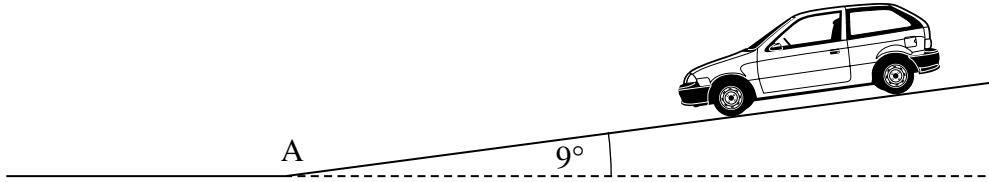

10 (a) The total mass of the car is 1200 kg.

10 (a) (i) Show that a force of about 1.8 kN acts down the slope due to the weight of the car.

.....
.....
.....
.....
.....

(2 marks)

10 (a) (ii) The car is travelling at a constant speed down the hill.

State the magnitude and direction of the resistive force acting on the car.

magnitude of resistive force N

direction of resistive force

(2 marks)



10 (b) The car reaches the end of the slope and moves onto a horizontal road at point A on **Figure 8**. The speed of the car at point A is 18 m s^{-1} . Assume that the resistive force does not change from its value in part (a)(ii). Calculate the time that elapses, after passing point A, before the car stops.

.....
.....
.....
.....
.....
.....
.....
.....

time taken to stop s
(4 marks)

Question 10 continues on the next page

Turn over ►



