

**Thursday 17 May 2012 – Morning**

**AS GCE PHYSICS B (ADVANCING PHYSICS)**

**G491** Physics in Action

Candidates answer on the Question Paper.

**OCR supplied materials:**

- Data, Formulae and Relationships Booklet (sent with general stationery)

**Other materials required:**

- Electronic calculator
- Ruler (cm/mm)

**Duration: 1 hour**



Candidate forename		Candidate surname	
--------------------	--	-------------------	--

Centre number							Candidate number				
---------------	--	--	--	--	--	--	------------------	--	--	--	--

**INSTRUCTIONS TO CANDIDATES**

- Write your name, centre number and candidate number in the boxes above. Please write clearly and in capital letters.
- Use black ink. HB pencil may be used for graphs and diagrams only.
- Read each question carefully. Make sure you know what you have to do before starting your answer.
- Show clearly the working in all calculations, and give answers to only a justifiable number of significant figures.
- Write your answer to each question in the space provided. Additional paper may be used if necessary but you must clearly show your candidate number, centre number and question number(s).
- Answer **all** the questions.
- Do **not** write in the bar codes.

**INFORMATION FOR CANDIDATES**

- The number of marks is given in brackets [ ] at the end of each question or part question.
- The total number of marks for this paper is **60**.
- You are advised to spend about 20 minutes on Section A and 40 minutes on Section B.
- The values of standard physical constants are given in the Data, Formulae and Relationships Booklet. Any additional data required are given in the appropriate question.
-  Where you see this icon you will be awarded marks for the quality of written communication in your answer.  
This means, for example, you should
  - ensure that text is legible and that spelling, punctuation and grammar are accurate so that meaning is clear;
  - organise information clearly and coherently, using specialist vocabulary when appropriate.
- This document consists of **16** pages. Any blank pages are indicated.

Answer **all** the questions.

**Section A**

- 1 The two columns below list the usual units of four electrical quantities and a set of equivalent alternative units.

units	equivalents
A	$\text{J s}^{-1}$
V	$\text{V A}^{-1}$
W	$\text{C s}^{-1}$
$\Omega$	$\text{J C}^{-1}$

Draw a straight line from each **unit** box to the corresponding **equivalent** box.

[3]

- 2 The two columns below list four mechanical properties of materials and a set of definitions.

properties	definitions
stiff	the force per unit cross-sectional area
stress	difficult to indent or scratch
hard	a small strain for a large stress on a material
tough	needs a large energy to break and create a new fracture surface

Draw a straight line from each **property** box to the corresponding **definition** box.

[3]

- 3 Two resistors are connected in series to a 6.0V supply of negligible internal resistance as shown in Fig. 3.1.

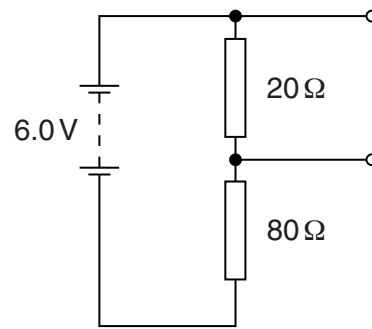

Fig. 3.1

- (a) Show that the p.d. across the 20Ω resistor is greater than 1V.

[2]

- (b) Calculate the power dissipated in the 20Ω resistor.

power = ..... W [2]

- 4 A resistance thermometer uses changes in resistance with temperature to measure temperature. Fig. 4.1 is the calibration graph of its resistance against temperature.

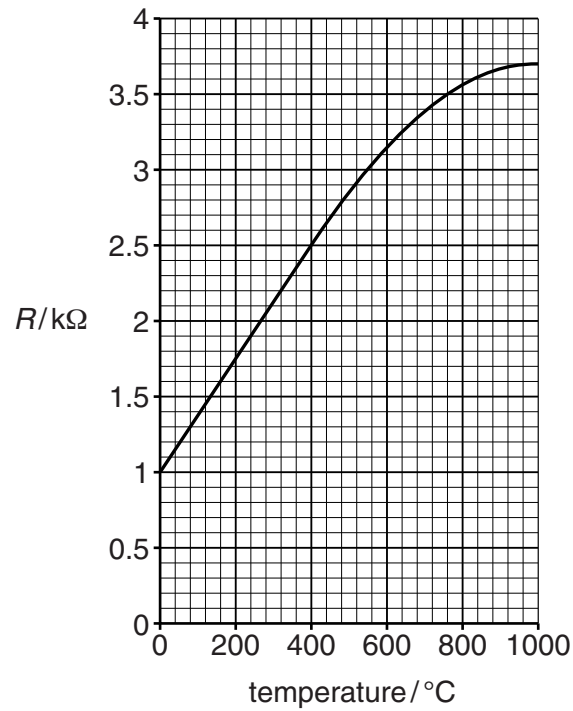

**Fig. 4.1**

- (a) Calculate the sensitivity of the thermometer at  $200^{\circ}C$ .

sensitivity = .....  $\Omega^{\circ}C^{-1}$  [2]

- (b) Describe what happens to the sensitivity of the thermometer as the temperature increases from  $0^{\circ}C$  to  $1000^{\circ}C$ .

[2]

- 5 Fig. 5.1 shows a lens system being used to make a micro-circuit by producing a tiny image.

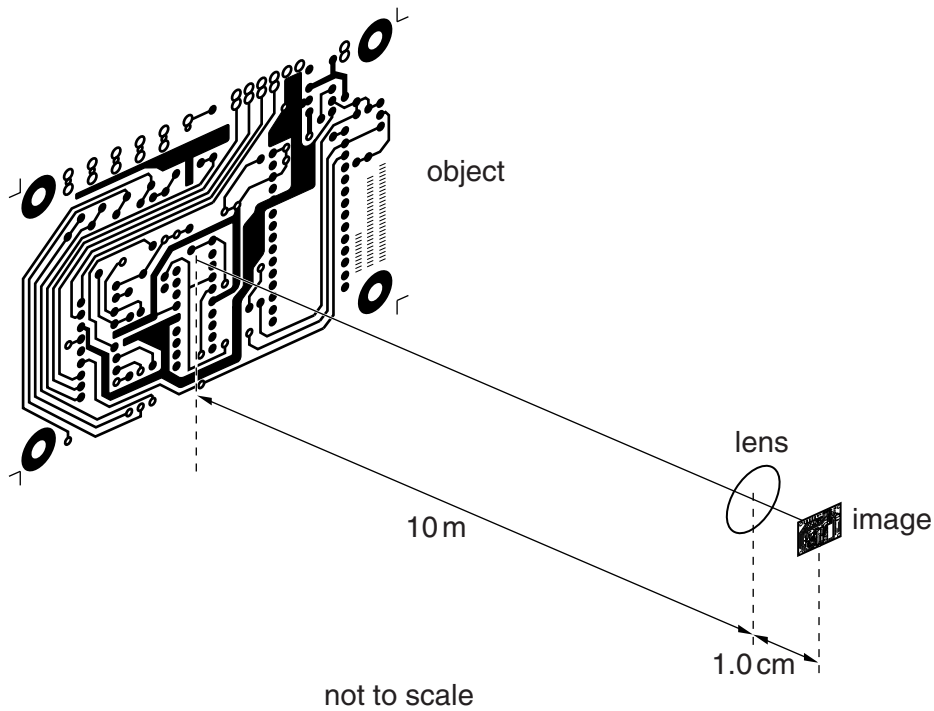

**Fig. 5.1**

- (a) Calculate the magnification of the lens system using the data in Fig. 5.1.

magnification = ..... [2]

- (b) Calculate the power of the lens needed to achieve this magnification.

Make your method clear.

power = ..... D [3]

- 6 Fig. 6.1 shows an image of the Andromeda galaxy taken by the Hubble Space Telescope. The image contains  $4096 \times 3072$  pixels as shown.

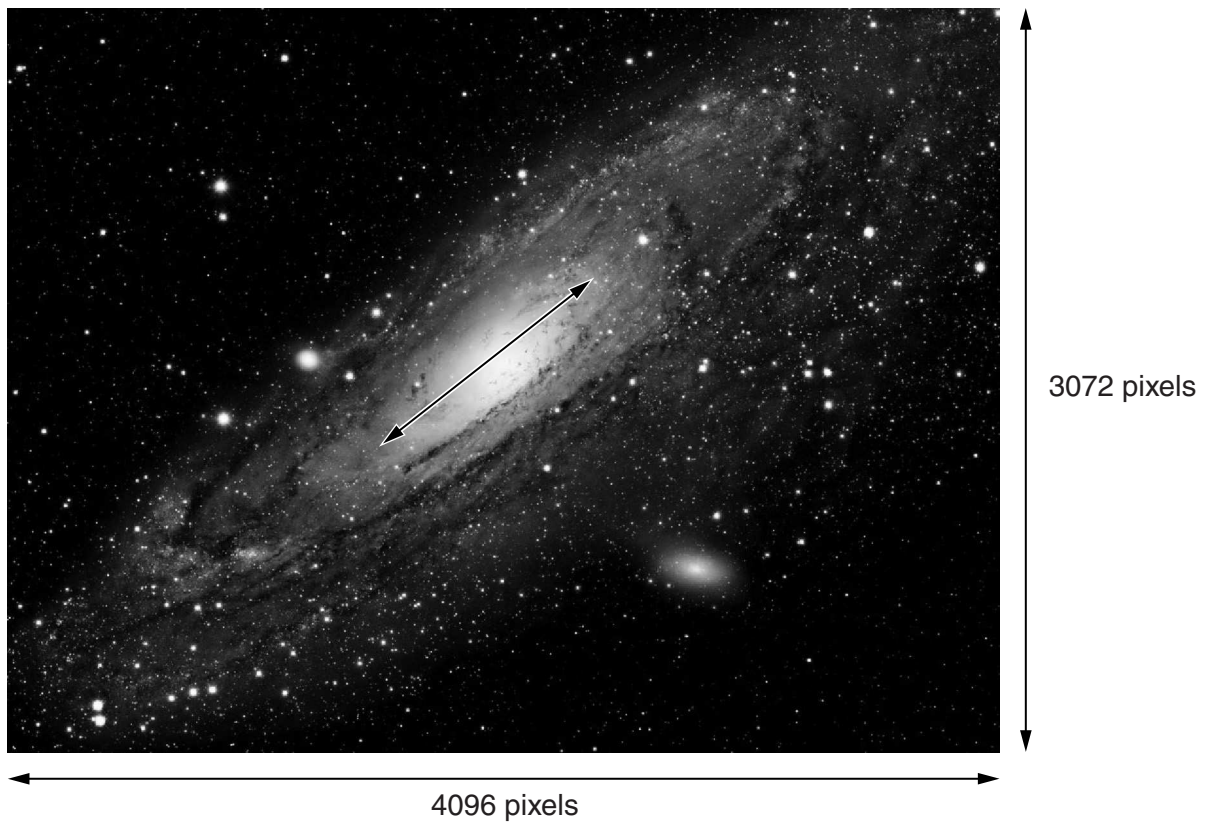

**Fig. 6.1**

The resolution of the image is 30 light years per pixel.

Calculate the diameter of the galactic nucleus indicated by the arrow in Fig. 6.1.

Make your method clear.

diameter = ..... light years [3]

7 Here is a list of numbers.

0.005

0.05

0.5

5.0

50

Write down the number from the list which is the closest estimate for:

(a) the breaking strain of a rubber band .....

(b) the power in kW for a 'one cup' kettle ..... kW  
[2]

[Section A Total: 24]

## Section B

8 This question is about stretching polythene.

(a) A long narrow sample strip of polythene is cut from a shopping bag. It stretches elastically up to a strain of 0.082 at a stress of 14 MPa. This is the elastic limit of the material.

(i) Calculate the Young modulus of the polythene and state the unit.

Young modulus = ..... unit ..... [3]

(ii) The cross-sectional area of the sample is  $1.9 \times 10^{-7} \text{ m}^2$ .

Calculate the force applied to the sample to produce a stress of 14 MPa.

force = ..... N [2]

(b) Fig. 8.1 shows the stress against strain graph for the sample to its breaking point.

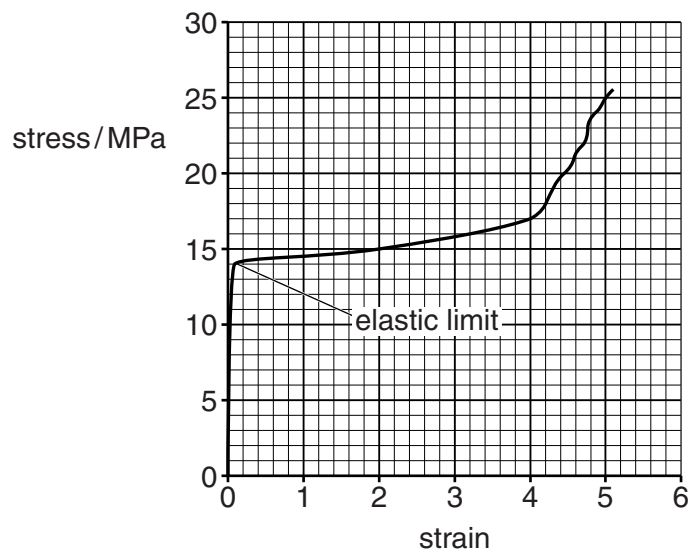

Fig. 8.1



- (i) Describe the behaviour of the sample as it is stretched from the elastic limit to its breaking point.

[2]

- (ii) Use Fig. 8.1 to calculate the extension of the sample at the breaking point.

The original length of the sample is 15 cm.

extension = ..... cm [3]

- (c) Suggest and explain what is happening to the **long chain molecules** in the sample between the elastic limit and the breaking point as stress is increased slowly.

You may wish to use labelled diagrams.



*In your answer you should use appropriate technical terms spelled correctly.*

[4]

[Total: 14]

Turn over

- 9 One method of calibrating a voltmeter is to measure the known p.d. across a standard cell. A standard cell is one whose emf is stable and accurately known.

One such standard cell has an emf  $\varepsilon$  of 1.019V at room temperature.

- (a) State the number of significant figures in this emf value.

number of significant figures = ..... [1]

- (b) The uncertainty in the emf is given as  $1.019 \pm 0.001$  V.

Calculate the % uncertainty implied by this data.

% uncertainty = ..... % [1]

- (c) The p.d. across the cell may change if the current exceeds  $2.8 \mu\text{A}$  or if more than  $10 \mu\text{C}$  of charge are drawn in any measurement.  
The internal resistance of the standard cell is  $350 \Omega$ .

- (i) In a particular voltmeter calibration by a student the current drawn is  $1.1 \mu\text{A}$ .

Show that the maximum time the student has to complete the measurement is less than 10s.

[2]

- (ii) Calculate the resistance of the voltmeter being calibrated.

Make your method clear.

resistance of voltmeter = .....  $\Omega$  [3]

- (iii) Calculate the voltage drop across the internal resistance of the standard cell during the calibration.

voltage drop = ..... V [2]

- (d) Suggest and explain a problem that would arise in an attempt to calibrate a voltmeter of much lower internal resistance using this standard cell.

[2]

[Total: 11]

**10** This question is about a 3-D television system. The TV screen contains  $1920 \times 1080$  colour-pixels. Each colour-pixel consists of three sub-pixels, one red, one green and one blue.

**(a) (i)** The intensity of light emitted by each sub-pixel in the screen is coded by a 12 bit number.

Calculate the number of alternative intensities for each sub-pixel.

number of intensities = ..... **[1]**

**(ii)** Show that about 75Mbits of uncompressed information are needed to produce one image on the screen.

**[1]**

**(iii)** 120 images are displayed on the screen each second.

Estimate the bandwidth required for transmission of uncompressed image data for this TV system. Make your method clear.

bandwidth = ..... Hz **[2]**

**(b)** Light emitted from the 3-D TV screen is unpolarised. To produce a 3-D effect viewers wear glasses containing polarising filters.

**(i)** Explain the difference between unpolarised and polarised light.

You should use labelled diagrams in your explanation.

**[3]**

**Please turn over for question 10(b)(ii).**

- (ii) The images on the TV screen alternate between the views which should be seen by the left and right eyes. An electronic signal to the glasses, synchronised with the TV images, causes the light to be blocked alternately to the left and right eyes. See Fig. 10.1. Each eye sees 60 frames per second, and then the brain integrates these into a single 3-D image with no flicker.

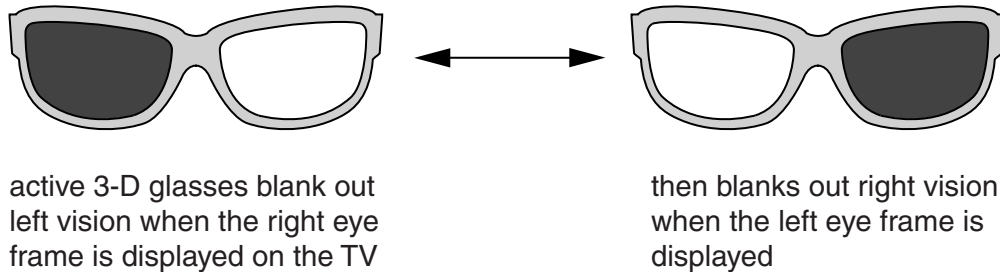

**Fig. 10.1**

Each lens contains two polarising filters. One filter has a fixed plane of polarisation; the other is made from a liquid-crystal material. This material acts as a polarising filter when a voltage is applied across it.

Using your knowledge of polarisation suggest and explain how the glasses alternately block the light to the left and right eye.



*Organise your explanation clearly and coherently.*

[4]

[Total: 11]

[Section B Total: 36]

**END OF QUESTION PAPER**

15  
BLANK PAGE

PLEASE DO NOT WRITE ON THIS PAGE

**PLEASE DO NOT WRITE ON THIS PAGE**



**Copyright Information**

OCR is committed to seeking permission to reproduce all third-party content that it uses in its assessment materials. OCR has attempted to identify and contact all copyright holders whose work is used in this paper. To avoid the issue of disclosure of answer-related information to candidates, all copyright acknowledgements are reproduced in the OCR Copyright Acknowledgements Booklet. This is produced for each series of examinations and is freely available to download from our public website ([www.ocr.org.uk](http://www.ocr.org.uk)) after the live examination series.

If OCR has unwittingly failed to correctly acknowledge or clear any third-party content in this assessment material, OCR will be happy to correct its mistake at the earliest possible opportunity.

For queries or further information please contact the Copyright Team, First Floor, 9 Hills Road, Cambridge CB2 1GE.

OCR is part of the Cambridge Assessment Group; Cambridge Assessment is the brand name of University of Cambridge Local Examinations Syndicate (UCLES), which is itself a department of the University of Cambridge.