

Write your name here

Surname

Other names

Centre Number

Candidate Number

**Edexcel GCSE**

# Mathematics B

**Unit 2: Number, Algebra, Geometry 1  
(Non-Calculator)**

**Higher Tier**

Thursday 8 November 2012 – Afternoon

**Time: 1 hour 15 minutes**

Paper Reference

**5MB2H/01**

**You must have:** Ruler graduated in centimetres and millimetres, protractor, pair of compasses, pen, HB pencil, eraser. Tracing paper may be used.

Total Marks

## Instructions

- Use **black** ink or ball-point pen.
- **Fill in the boxes** at the top of this page with your name, centre number and candidate number.
- Answer **all** questions.
- Answer the questions in the spaces provided – *there may be more space than you need.*
- **Calculators must not be used.**



## Information

- The total mark for this paper is 60
- The marks for **each** question are shown in brackets – *use this as a guide as to how much time to spend on each question.*
- Questions labelled with an **asterisk** (\*) are ones where the quality of your written communication will be assessed.

## Advice

- Read each question carefully before you start to answer it.
- Keep an eye on the time.
- Try to answer every question.
- Check your answers if you have time at the end.

Turn over ►

P40669A

©2012 Pearson Education Ltd.

6/6/7/



**PEARSON**

## GCSE Mathematics 2MB01

Formulae: Higher Tier

**You must not write on this formulae page.  
Anything you write on this formulae page will gain NO credit.**

**Volume of prism** = area of cross section  $\times$  length

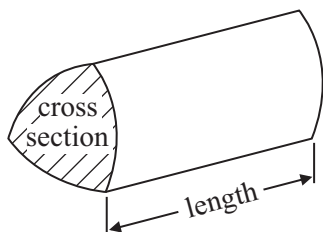

**Area of trapezium** =  $\frac{1}{2} (a + b)h$

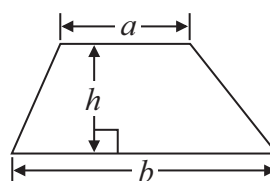

**Volume of sphere** =  $\frac{4}{3} \pi r^3$

**Surface area of sphere** =  $4\pi r^2$

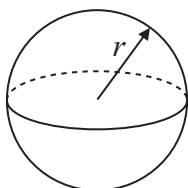

**Volume of cone** =  $\frac{1}{3} \pi r^2 h$

**Curved surface area of cone** =  $\pi r l$

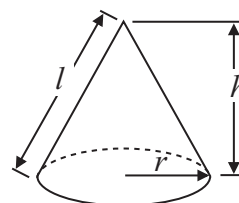

**In any triangle ABC**



**The Quadratic Equation**

The solutions of  $ax^2 + bx + c = 0$   
where  $a \neq 0$ , are given by

$$x = \frac{-b \pm \sqrt{b^2 - 4ac}}{2a}$$

**Sine Rule**  $\frac{a}{\sin A} = \frac{b}{\sin B} = \frac{c}{\sin C}$

**Cosine Rule**  $a^2 = b^2 + c^2 - 2bc \cos A$

**Area of triangle** =  $\frac{1}{2} ab \sin C$



**Answer ALL questions.**

**Write your answers in the spaces provided.**

**You must write down all stages in your working.**

**You must NOT use a calculator.**

- 1** Richard's car uses 1 litre of petrol every 8 miles.  
Petrol costs £1.30 per litre.

Richard drives 240 miles.

Work out the total cost of the petrol the car uses.

£ .....

**(Total for Question 1 is 3 marks)**

---



2 Here is a list of ingredients for making apple crumble for 2 people.

**Apple Crumble  
for 2 people**

10 ounces apples  
4 ounces flour  
2 ounces sugar  
1 ounce butter  
1 tablespoon water  
1 teaspoon baking powder

1 ounce = 28 grams

1 tablespoon = 15 ml

1 teaspoon = 5 ml

Anne is going to make apple crumble for 5 people.

- (a) Work out how much flour she needs.  
Give your answer in grams.

..... grams  
(3)



David is making an apple crumble.  
He uses 140 grams of butter.

(b) Work out how many people he is making apple crumble for.

.....  
(2)

**(Total for Question 2 is 5 marks)**

---



3 Here is a right-angled triangle.

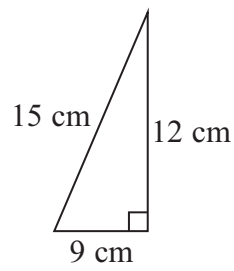

Diagram **NOT** accurately drawn

The shape below is made from 4 of these triangles.

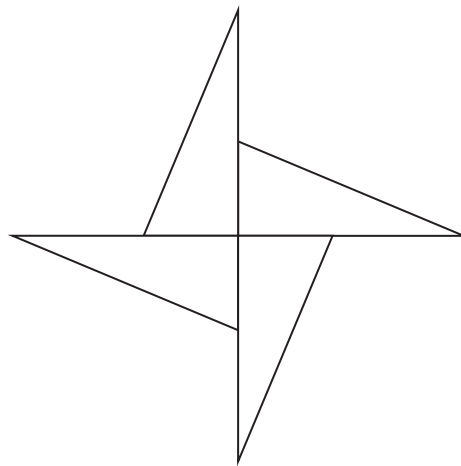

Diagram **NOT** accurately drawn

Work out the perimeter of the shape.

..... cm

**(Total for Question 3 is 3 marks)**



4 (a) Express 54 as a product of its prime factors.

.....  
(2)

(b) Find the Lowest Common Multiple (LCM) of 45 and 54

.....  
(2)

**(Total for Question 4 is 4 marks)**



- 5 You can use the graph opposite to find out how much Lethna has to pay for the units of electricity she has used.

Lethna pays at one rate for the first 100 units of electricity she uses.  
She pays at a different rate for all the other units of electricity she uses.

Lethna uses a total of 900 units of electricity.

Work out how much she must pay.

£.....





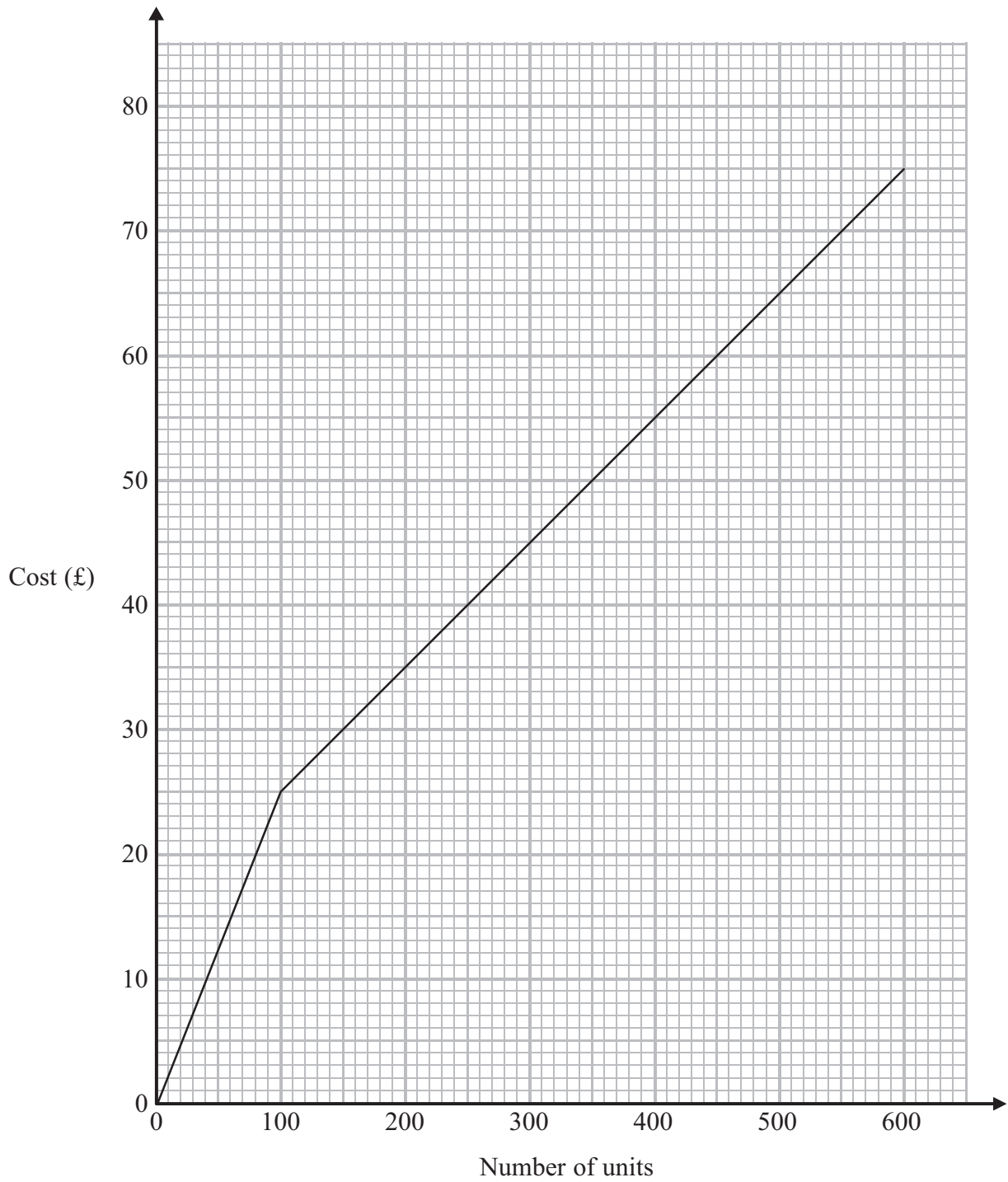

**(Total for Question 5 is 3 marks)**



6 The diagram shows a wall in Neil's house.

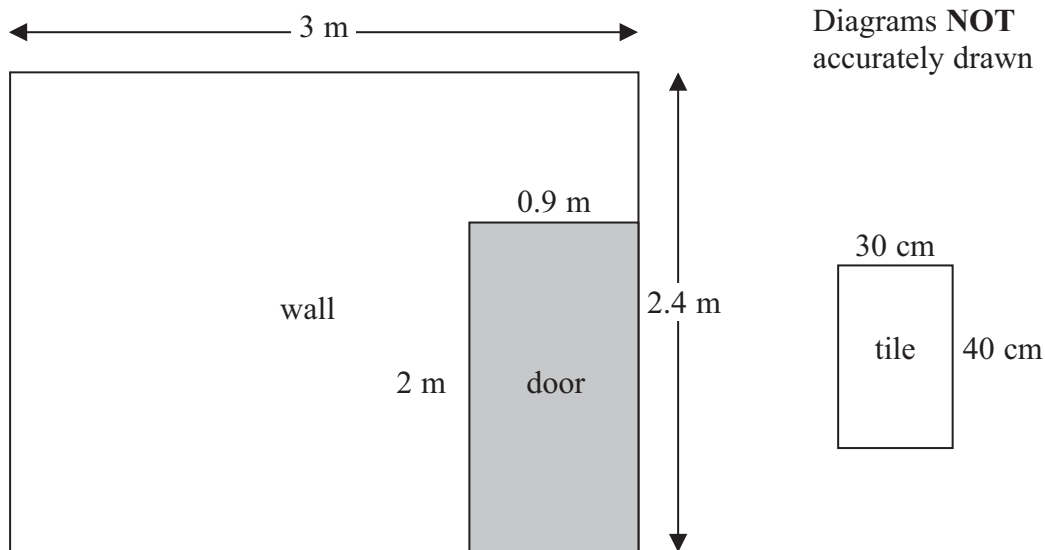

Neil is going to cover the wall completely with tiles.  
Each tile has a width of 30 cm and a height of 40 cm.

The tiles are sold in packs.  
There are 6 tiles in each pack.  
Each pack costs £15

Work out the least amount of money Neil needs to pay for the tiles.  
You must show all your working.

£ .....

(Total for Question 6 is 4 marks)



7 Using the information that

$$170.2 \div 4.6 = 37$$

write down the value of

(a)  $1702 \div 4.6$

.....  
(1)

(b)  $170.2 \div 460$

.....  
(1)

(c)  $3.7 \times 4.6$

.....  
(1)

**(Total for Question 7 is 3 marks)**

---



8 Here are the first five terms of an arithmetic sequence.

4      11      18      25      32

(a) Write down, in terms of  $n$ , an expression for the  $n$ th term of this sequence.

.....  
(2)

An expression for the  $n$ th term of another sequence is  $3n^2 - 1$

(b) Find the fourth term of this sequence.

.....  
(2)

**(Total for Question 8 is 4 marks)**

---



9

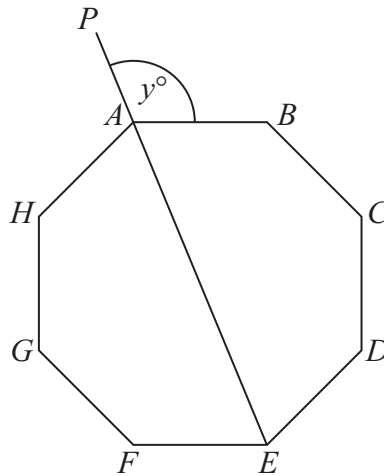

Diagram **NOT** accurately drawn

$ABCDEFGH$  is a regular octagon.  
 $PAE$  is a straight line.

Angle  $PAB = y^\circ$

Work out the value of  $y$

$y = \dots\dots\dots$

(Total for Question 9 is 4 marks)



10 (a) Write 125 000 in standard form.

.....  
(1)

(b) Write  $8 \times 10^{-4}$  as an ordinary number.

.....  
(1)

**(Total for Question 10 is 2 marks)**

---



11

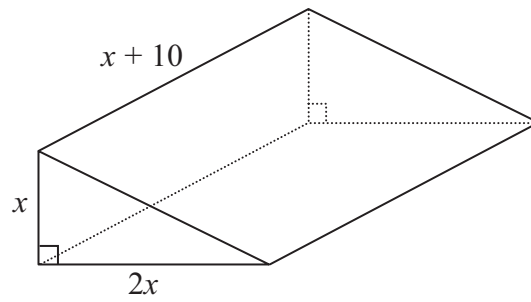

Diagram **NOT**  
accurately drawn

The diagram shows a solid triangular prism.  
All the measurements are in centimetres.

The volume of the prism is  $V \text{ cm}^3$ .

Find a formula for  $V$  in terms of  $x$ .  
Give your answer in simplified form.

.....  
(Total for Question 11 is 3 marks)



12

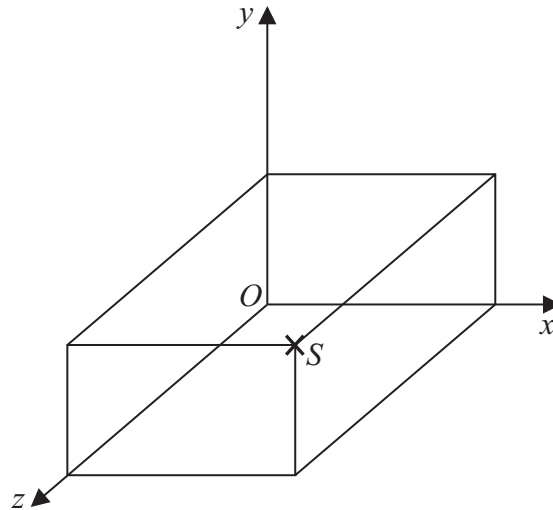

Diagram **NOT** accurately drawn

The diagram shows a cuboid drawn on a 3-D grid.

Three of the vertices of the cuboid are  $P(3, 2, 0)$   
 $Q(3, 0, 0)$   
 $R(3, 0, 4)$

(a) Label the vertex  $Q$  with a cross ( $\times$ ).

(1)

The vertex  $S$  is shown on the diagram.

(b) Write down the coordinates of the vertex  $S$ .

(....., ....., .....)  
(1)

**(Total for Question 12 is 2 marks)**





**13** Write down the value of

(i)  $4^{-2}$

(ii)  $64^{\frac{1}{3}}$

.....

.....

---

**(Total for Question 13 is 2 marks)**

---



14 (a) Factorise  $x^2 + 5x + 4$

.....  
(2)

(b) Expand and simplify  $(3x - 1)(2x + 5)$

.....  
(2)

(c) Write as a single fraction  $\frac{1}{2x} + \frac{1}{5x} - \frac{1}{3x}$

.....  
(2)

**(Total for Question 14 is 6 marks)**

---



\*15

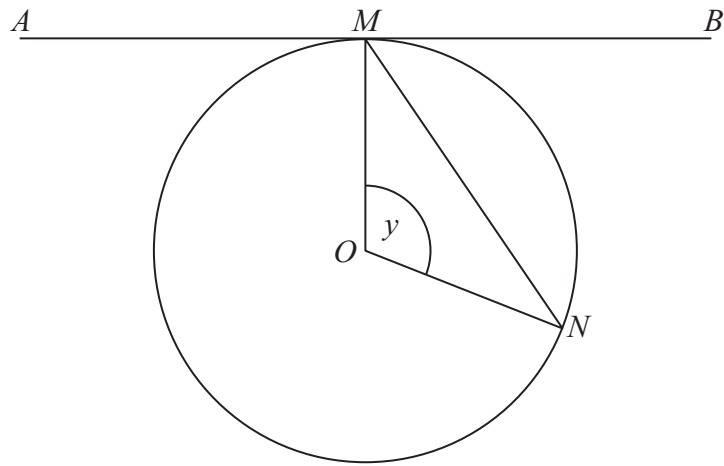

Diagram NOT  
accurately drawn

$M$  and  $N$  are two points on the circumference of a circle centre  $O$ .  
The straight line  $AMB$  is the tangent to the circle at  $M$ .

Angle  $MON = y$

Prove that angle  $BMN = \frac{1}{2}y$

(Total for Question 15 is 5 marks)



16

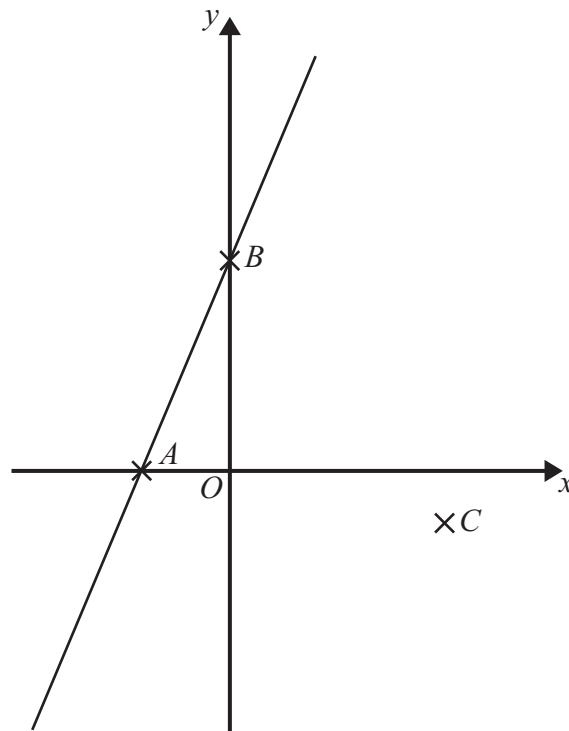

Diagram **NOT**  
accurately drawn

In the diagram

$A$ is the point	$(-2, 0)$
$B$ is the point	$(0, 4)$
$C$ is the point	$(5, -1)$

Find an equation of the line that passes through  $C$  and is perpendicular to  $AB$ .

.....  
(Total for Question 16 is 4 marks)



17 Rationalise the denominator of  $\frac{(6 - \sqrt{5})(6 + \sqrt{5})}{\sqrt{31}}$

Give your answer in its simplest form.

.....  
**(Total for Question 17 is 3 marks)**

---

**TOTAL FOR PAPER IS 60 MARKS**



**BLANK PAGE**



**BLANK PAGE**



**BLANK PAGE**

