

OCR

Oxford Cambridge and RSA

Tuesday 2 June 2015 – Afternoon

AS GCE CHEMISTRY A

F322/01 Chains, Energy and Resources

Candidates answer on the Question Paper.

OCR supplied materials:

- *Data Sheet for Chemistry A* (inserted)

Other materials required:

- Scientific calculator

Duration: 1 hour 45 minutes



Candidate forename		Candidate surname	
--------------------	--	-------------------	--

Centre number						Candidate number				
---------------	--	--	--	--	--	------------------	--	--	--	--

INSTRUCTIONS TO CANDIDATES

- The Insert will be found inside this document.
- Write your name, centre number and candidate number in the boxes above. Please write clearly and in capital letters.
- Use black ink. HB pencil may be used for graphs and diagrams only.
- Answer **all** the questions.
- Read each question carefully. Make sure you know what you have to do before starting your answer.
- Write your answer to each question in the space provided. If additional space is required, you should use the lined pages at the end of this booklet. The question number(s) must be clearly shown.
- Do **not** write in the bar codes.

INFORMATION FOR CANDIDATES

- The number of marks is given in brackets [] at the end of each question or part question.
-  Where you see this icon you will be awarded marks for the quality of written communication in your answer.

This means for example you should:

- ensure that text is legible and that spelling, punctuation and grammar are accurate so that meaning is clear;
- organise information clearly and coherently, using specialist vocabulary when appropriate.
- You may use a scientific calculator.
- A copy of the *Data Sheet for Chemistry A* is provided as an insert with this question paper.
- You are advised to show all the steps in any calculations.
- The total number of marks for this paper is **100**.
- This document consists of **24** pages. Any blank pages are indicated.

Answer **all** the questions.

1 This question is about different alkanes present in crude oil.

(a) Compound **A**, shown below, is one of the structural isomers of C_7H_{16} .

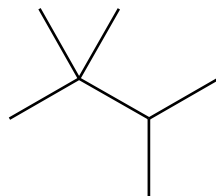

Compound A

(i) What is meant by the term *structural isomers*?

.....

 [1]

(ii) Name compound **A**.

..... [1]

(b) The structural isomers of C_5H_{12} have different boiling points.

Draw the **skeletal formula** of the structural isomer of C_5H_{12} with the highest boiling point.

[1]

(c) A molecule of an alkane has 24 carbon atoms.

State the empirical formulae of this alkane.

..... [1]

(d) Alkanes are used as fuels.

(i) Construct an equation for the complete combustion of octane C_8H_{18} .

..... [1]

(ii) Combustion of 36.48 g of octane produced 2.50 mol of carbon dioxide.

Show that this combustion was incomplete.

[2]

(e) Alkanes in crude oil can be used to manufacture ethene. Two stages are required.

(i) Name the **two** stages.

.....

..... [1]

(ii) Write an equation for the preparation of ethene from an alkane.

..... [1]

[Total: 9]

2 Butan-2-ol can be prepared using two different methods.

Method 1

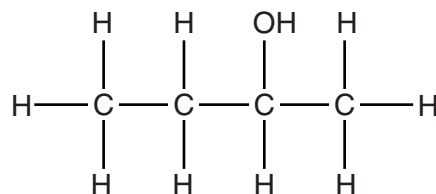
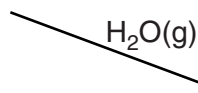
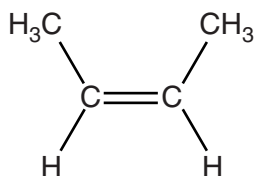

Method 2

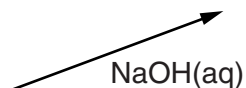
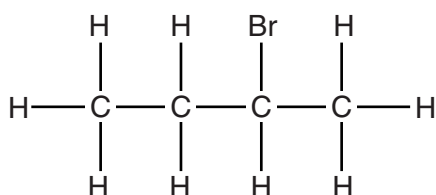

butan-2-ol

(a) Comment on the atom economy of each method, giving your reasons.

.....

 [2]

(b) State the catalyst required for **Method 1**.

..... [1]

(c) Average bond enthalpies can be used to calculate enthalpy changes.

(i) What is meant by the term *average bond enthalpy*?

.....

 [2]

- (ii) Calculate the enthalpy change of reaction, ΔH_r , for preparing 1 mol of butan-2-ol by **Method 1**.

Average bond enthalpies are given below.

Bond	Average bond enthalpy/kJ mol ⁻¹
O–H	464
C–H	413
C–C	347
C–O	358
C=C	612

$$\Delta H_r = \dots\dots\dots \text{kJ mol}^{-1} \quad [3]$$

- (d) A student uses **Method 2** to prepare 3.552 g of butan-2-ol from 2-bromobutane. The percentage yield of butan-2-ol is 80.0%.

Calculate the mass of 2-bromobutane that the student uses.
Give your answer to **three** significant figures.

$$\text{mass of 2-bromobutane} = \dots\dots\dots \text{g} \quad [3]$$

[Total: 11]

Turn over

3 Methanol, CH₃OH, is an important feedstock for the chemical industry.

In the manufacture of methanol, carbon dioxide and hydrogen are reacted together in the reversible reaction shown below.

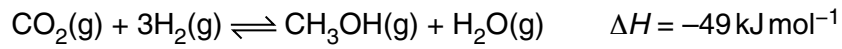

(a) Describe and explain the effect of increasing the pressure on the reaction **rate**.

.....

 [2]

(b) State le Chatelier's principle.

.....

 [1]

(c) High pressures and low temperatures would give a maximum equilibrium yield of methanol.

(i) Explain this statement in terms of le Chatelier's principle.

.....

 [3]

(ii) Explain why the actual conditions used by the chemical industry might be different.

.....

 [2]

(d) The manufacture of methanol uses a catalyst.

- Sketch a labelled diagram of the Boltzmann distribution on the grid provided.
- Label your axes.
- Using your Boltzmann distribution, explain how the catalyst increases the rate of reaction.

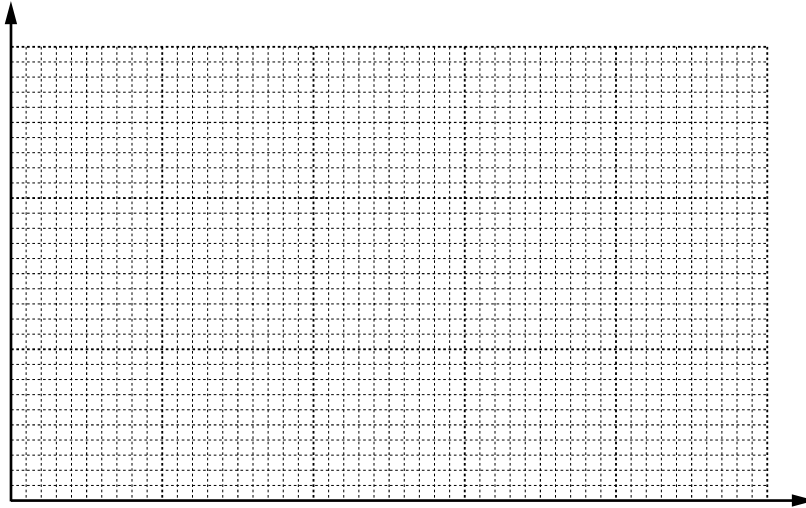

.....
.....
.....
.....
..... [4]

(e) Explain why the use of a catalyst can reduce the demand for energy.

.....
.....
..... [1]

[Total: 13]

4 This question is about the compounds shown below.

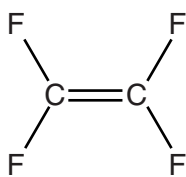
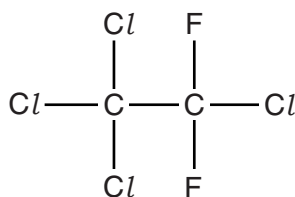
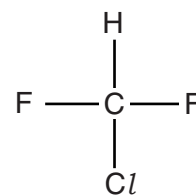
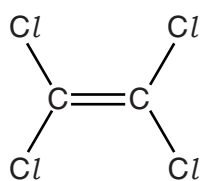
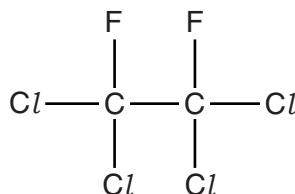
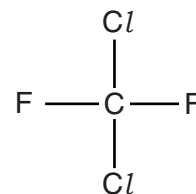
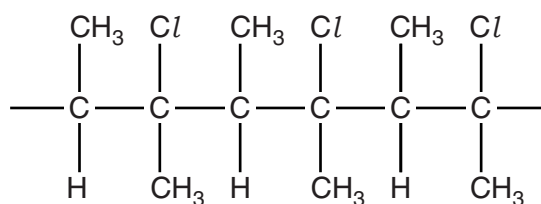
**B****C****D****E****F****G****H**

(a) Which compound, **B** to **H**, could be used to make the polymer PTFE?

..... [1]

(b) Polymer **H** can be disposed of by combustion. One environmental problem is the production of toxic gases, such as CO.

(i) Draw the structure of the monomer needed to produce polymer **H**.

[1]

(ii) Give the formula of an acidic toxic gas that could form during combustion of polymer **H**.

..... [1]

(c) Compound **G** was once used as a propellant in aerosols. Compound **G** has been linked with depletion of the ozone layer in the stratosphere.

(i) State **two** properties that made compound **G** suitable for use as an aerosol.

- 1
- 2 [1]

(ii) Explain the following statements, using equations where appropriate.

- Life on Earth benefits from the presence of an ozone layer.
- The concentration of ozone is maintained in the ozone layer.
- Compound **G** produces radicals which catalyse the breakdown of ozone.

.....
.....
.....
.....
.....
.....
.....
.....
.....
.....
.....
.....
.....
.....
.....
.....
.....
.....
..... [5]

(iii) Alternative ‘ozone-friendly’ compounds are now used as propellants instead of compound **G**.

Which compound, **B** to **H**, might be suitable as an ‘ozone-friendly’ propellant?

..... [1]

(d) Compounds **C** and **F** can be analysed to obtain infrared and mass spectra.

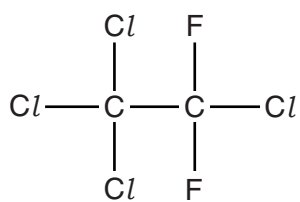
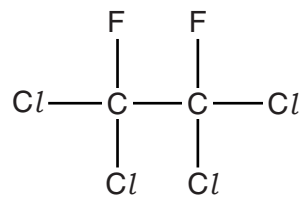
**C****F**

(i) What happens to molecules when infrared radiation is absorbed?

..... [1]

(ii) Suggest the molecular formulae of **two** ions responsible for peaks in the mass spectrum of **C** that are **not** in the mass spectrum of **F**.

.....

..... [2]

[Total: 13]

11
BLANK PAGE

Question 5 starts on page 12
PLEASE DO NOT WRITE ON THIS PAGE

5 Allyl bromide, $\text{CH}_2=\text{CHCH}_2\text{Br}$, is used in the production of polymers.

(a) Part of the $\text{C}=\text{C}$ double bond in allyl bromide is called a π -bond.

Draw a labelled diagram to show the formation of the π -bond.

[2]

(b) Allyl bromide is a member of a homologous series. Compounds in this series have the same general formula.

(i) What is meant by the term *homologous series*?

.....

 [2]

(ii) What is the general formula of the homologous series that has allyl bromide as a member?

..... [1]

(iii) Give the systematic name for allyl bromide.

..... [1]

(c) Reaction mechanisms use curly arrows and can involve electrophiles and nucleophiles.

(i) What does a *curly arrow* represent in mechanisms?

.....
 [1]

(ii) What is meant by the term *nucleophile*?

.....
 [1]

(d) Allyl bromide, $\text{CH}_2=\text{CHCH}_2\text{Br}$, reacts with aqueous sodium hydroxide.

(i) Outline the mechanism of this reaction.

Include curly arrows, relevant dipoles and final product(s).

[3]

(ii) Name the type of mechanism.

..... [1]

(e) Allyl bromide, $\text{CH}_2=\text{CHCH}_2\text{Br}$, reacts with bromine, Br_2 .

(i) Outline the mechanism of this reaction.

Include curly arrows, relevant dipoles and the structures of the intermediate and final product(s).

[4]

(ii) Name the type of mechanism.

..... [1]

(f) Allyl bromide is reacted as shown below.

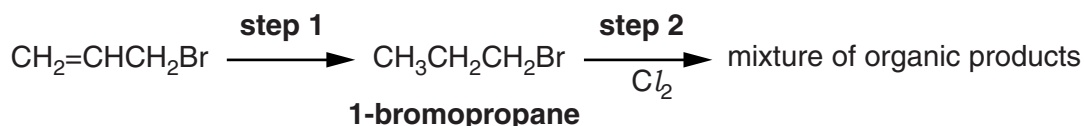

(i) State the reagents and conditions for **step 1**.

..... [1]

(ii) In **step 2**, 1-bromopropane reacts with chlorine by radical substitution.

Outline the mechanism for the monochlorination of 1-bromopropane.

In your mechanism, you can show the formula of 1-bromopropane as $\text{C}_3\text{H}_7\text{Br}$.

Include the names of the three stages in this mechanism, state the essential conditions and all termination steps.

.....
.....
.....
.....
.....
.....
.....
.....
.....
.....
.....
.....
.....
.....
.....
.....
.....
.....
.....
.....
..... [5]

(iii) Radical substitution produces a mixture of organic products.

Suggest **two** reasons why.

.....
.....
.....
.....
.....
..... [2]

[Total: 25]

6 A branched-chain alcohol **J** is a liquid and has the molecular formula $C_5H_{12}O$.

(a) A student does an experiment to measure the enthalpy change of combustion, ΔH_c , of alcohol **J**.

(i) The student burns alcohol **J** using the apparatus below.

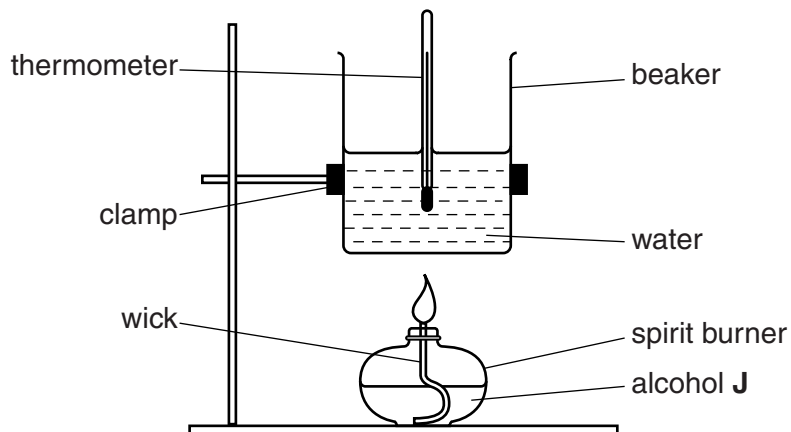

The student found that combustion of 1.54 g of alcohol **J** changes the temperature of 180 g of water from 22.8 °C to 75.3 °C.

The specific heat capacity of water is $4.18 \text{ J g}^{-1} \text{ K}^{-1}$.

- Calculate the amount, in mol, of alcohol **J** that burns.
- Calculate the enthalpy change of combustion, ΔH_c , of alcohol **J**, in kJ mol^{-1} .

Give your final answer to **three** significant figures.

$$\Delta H_c = \dots\dots\dots \text{kJ mol}^{-1} \quad [4]$$

- (ii) The calculated value of ΔH_c from this experiment is different from the value obtained from data books.

Apart from heat loss, suggest **two** reasons for the difference.

Assume that the calculation has been carried out correctly.

.....

.....

.....

..... [2]

- (b) The enthalpy change of combustion for alcohol **J** can also be determined indirectly from standard enthalpy changes of formation.

- (i) Write an equation, including state symbols, for the chemical change that represents the standard enthalpy change of formation of the liquid alcohol **J**, $C_5H_{12}O$.

..... [1]

- (ii) The equation for the complete combustion of alcohol **J** is shown below.

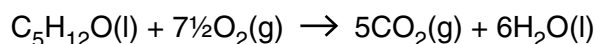

Enthalpy changes of formation, ΔH_f , are shown in the table.

Substance	$C_5H_{12}O(l)$	$CO_2(g)$	$H_2O(l)$
$\Delta H_f/kJmol^{-1}$	-366	-394	-286

Calculate the enthalpy change of combustion, ΔH_c , of alcohol **J** from the information given above.

$$\Delta H_c = \dots\dots\dots kJmol^{-1} \quad [3]$$

(d) The alcohol **J** is soluble in water.

Explain why alcohol **J** is soluble in water.

Use a labelled diagram to support your answer.

Include relevant dipoles and lone pairs.

.....

.....

..... [1]

[Total: 17]

19
BLANK PAGE

Question 7 starts on page 20
PLEASE DO NOT WRITE ON THIS PAGE

7 **L**, **M**, **N** and **P** are straight-chain organic compounds containing C, H and O only.

The flowchart shows reactions involving these compounds.

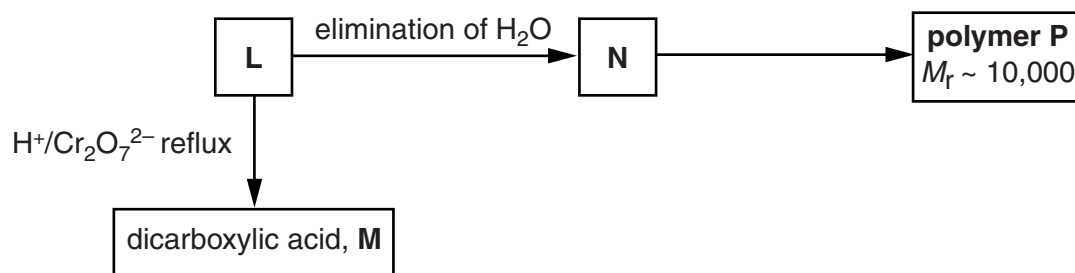

Analysis of compound **L** shows the following.

- Percentage composition by mass: C, 40.00%; H, 6.67%; O, 53.33%.
- Relative molecular mass of 90.0.
- The infrared spectrum below.

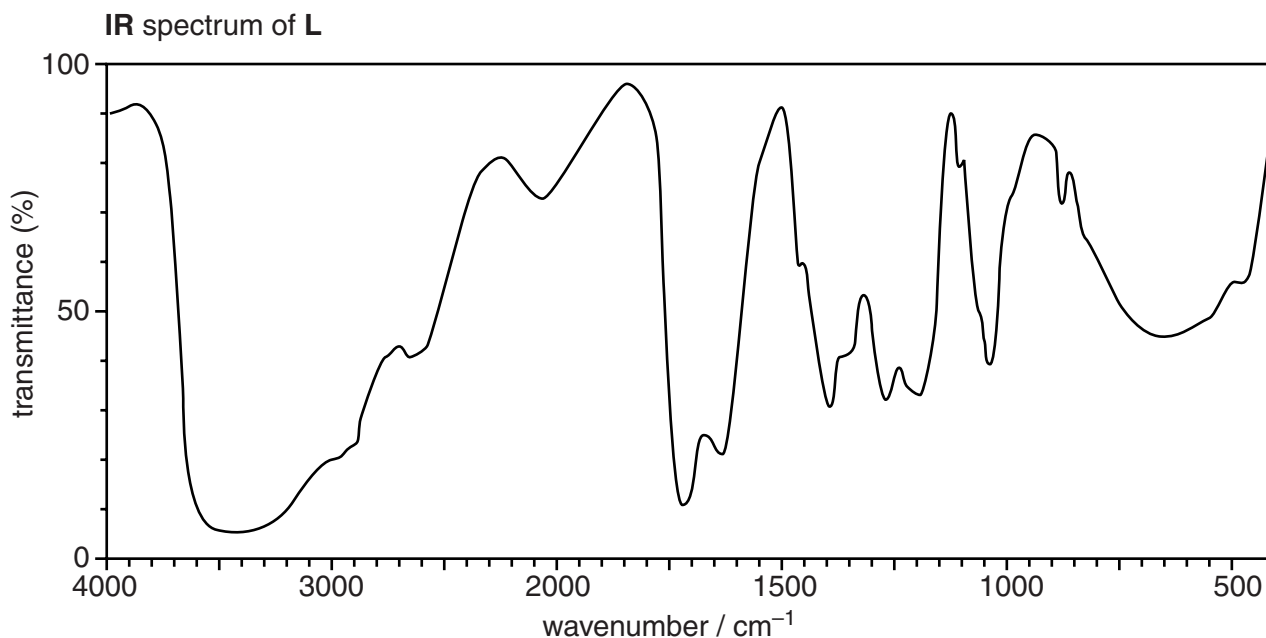

(a) Calculate the empirical and molecular formulae of compound **L**.

Show your working.

.....

.....

.....

.....

.....

.....

..... [3]

ADDITIONAL ANSWER SPACE

If additional answer space is required, you should use the following line page(s). The question number(s) must be clearly shown in the margins.

A large area of the page is reserved for additional answer space. It consists of a solid vertical line on the left side and a series of horizontal dotted lines extending across the page, providing a grid for writing.

A large rectangular area with a solid vertical line on the left side and horizontal dotted lines extending across the page, providing a space for writing answers.



Copyright Information

OCR is committed to seeking permission to reproduce all third-party content that it uses in its assessment materials. OCR has attempted to identify and contact all copyright holders whose work is used in this paper. To avoid the issue of disclosure of answer-related information to candidates, all copyright acknowledgements are reproduced in the OCR Copyright Acknowledgements Booklet. This is produced for each series of examinations and is freely available to download from our public website (www.ocr.org.uk) after the live examination series.

If OCR has unwittingly failed to correctly acknowledge or clear any third-party content in this assessment material, OCR will be happy to correct its mistake at the earliest possible opportunity.

For queries or further information please contact the Copyright Team, First Floor, 9 Hills Road, Cambridge CB2 1GE.

OCR is part of the Cambridge Assessment Group; Cambridge Assessment is the brand name of University of Cambridge Local Examinations Syndicate (UCLES), which is itself a department of the University of Cambridge.