

Please write clearly in block capitals.

Centre number

--	--	--	--	--

Candidate number

--	--	--	--

Surname

---

Forename(s)

---

Candidate signature

---

# GCSE MATHEMATICS (LINEAR)

# F

Foundation Tier Paper 2

Friday 4 November 2016

Morning

Time allowed: 1 hour 45 minutes

## Materials

For this paper you must have:

- a calculator
- mathematical instruments.



## Instructions

- Use black ink or black ball-point pen. Draw diagrams in pencil.
- Answer **all** questions.
- You must answer the questions in the spaces provided. Do not write outside the box around each page or on blank pages.
- Do all rough work in this book.

## Information

- The marks for questions are shown in brackets.
- The maximum mark for this paper is 105.
- The quality of your written communication is specifically assessed in Questions 5, 17 and 20. These questions are indicated with an asterisk (\*).
- You may ask for more answer paper, tracing paper and graph paper. These must be tagged securely to this answer book.

## Advice

- In all calculations, show clearly how you work out your answer.



**Formulae Sheet: Foundation Tier**

**Area of trapezium** =  $\frac{1}{2}(a+b)h$

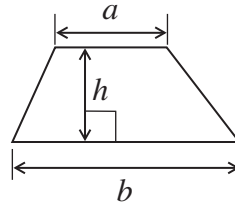

**Volume of prism** = area of cross section  $\times$  length

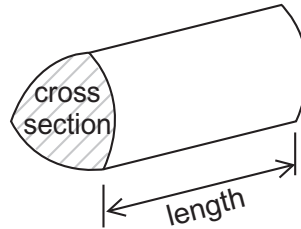

Answer **all** questions in the spaces provided.

- 1 (a)** Which two numbers add up to 100?  
Circle your answer.

[1 mark]

37 and 73

24 and 66

19 and 81

50 and 150

- 1 (b)** Which two numbers have a difference of 14?  
Circle your answer.

[1 mark]

81 and 57

12 and 2

2 and 7

22 and 8

- 1 (c)** Which two numbers have a product of 18?  
Circle your answer.

[1 mark]

3 and 6

3 and 15

15 and 33

36 and 2

**Turn over for the next question**



**2** Here are the ages of 20 students.

16	15	16	16	13
14	15	16	16	13
13	14	15	15	16
14	14	15	16	15

**2 (a)** Complete the tally and frequency columns in the table.

**[3 marks]**

Age	Tally	Frequency
13		
14		
15		
16		

**2 (b)** Write down the modal age.

**[1 mark]**

Answer \_\_\_\_\_

**2 (c)** One of the students is chosen at random.

Write down the probability that the student is 13 years old.

**[1 mark]**

\_\_\_\_\_

Answer \_\_\_\_\_



- 3 The diagram shows three rows of a tiling pattern.  
The pattern is made from 11 whole tiles and 2 half tiles.

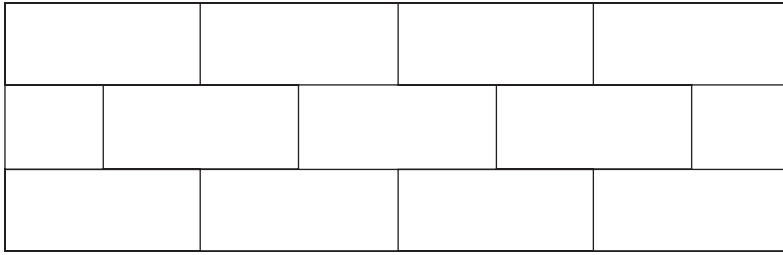

Using the same pattern,  
work out the number of whole tiles and half tiles needed altogether to tile this wall.

**[3 marks]**

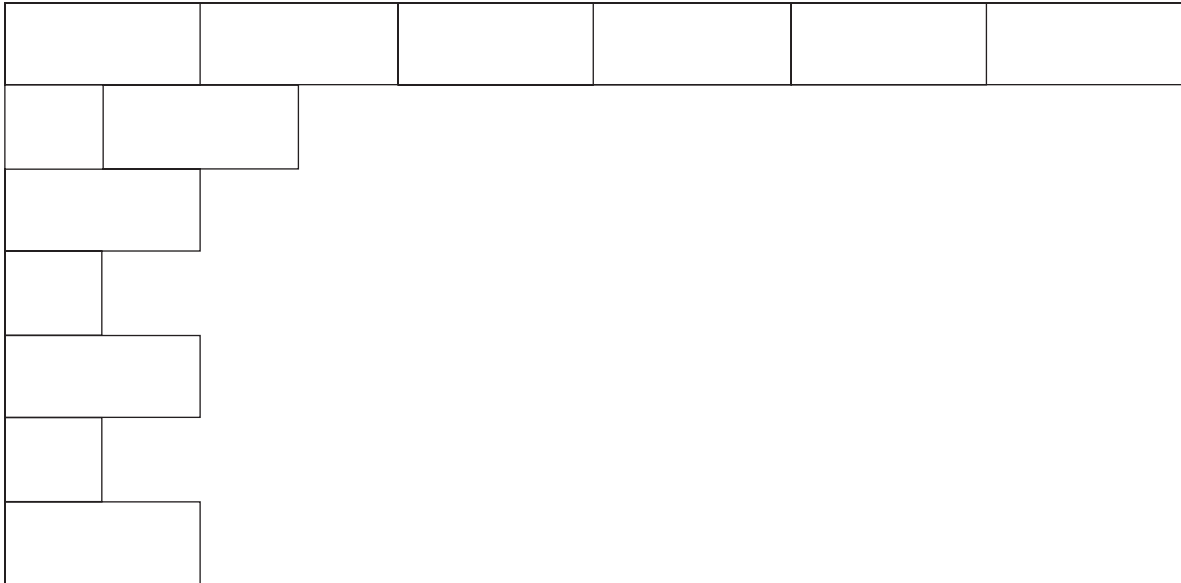

---



---



---

\_\_\_\_\_ whole tiles

\_\_\_\_\_ half tiles

8

Turn over ►



4 Jack is  $x$  years old.

Eric is three times Jack's age.  
Kate is 3 years younger than Jack.  
Suzy is 3 years younger than Kate.

4 (a) Match the people to their ages.  
One has been done for you.

[3 marks]

Jack	$x$
Eric	$x + 3$
Kate	$x - 3$
Suzy	$3x$
	$x - 6$

4 (b) Mary is 50 years old.  
She is 2 years older than Eric.

How old is Jack?

[2 marks]

---



---



---

Answer \_\_\_\_\_ years old



\*5 Tina buys the following items in a sale.

Item	Normal price	In the sale
Shirt	£20	£4.50 off
Trousers	£39	Half price
Shoes	£18.50	10% off
Scarf	£6.99	Save one-third

How much does she pay altogether?  
Complete the table below.

[5 marks]

---



---



---



---



---



---



---

Item	Sale price (£)
Shirt	
Trousers	
Shoes	
Scarf	
<b>Total</b>	



6 (a) Work out the size of angle  $x$ .

[1 mark]

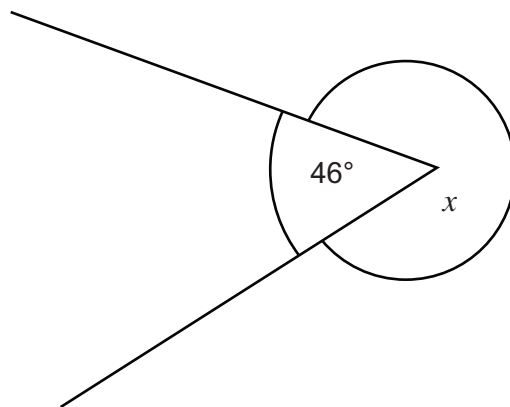

Not drawn accurately

---

Answer \_\_\_\_\_ degrees

6 (b) The time shown on a clock is 5 o'clock.

Work out the obtuse angle between the hour hand and the minute hand of the clock.

[2 marks]

---

---

Answer \_\_\_\_\_ degrees





7 (a) Work out the value of  $5x + 7y$  when  $x = 3$  and  $y = 4$

[2 marks]

---

---

Answer \_\_\_\_\_

7 (b) Work out the value of  $2w^2$  when  $w = 5.4$

[2 marks]

---

---

Answer \_\_\_\_\_

7 (c) Work out the value of  $2w^2$  when  $w = -5.4$

[1 mark]

Answer \_\_\_\_\_

7 (d) Simplify fully  $6a + 7b + 3b + a$

[2 marks]

---

---

Answer \_\_\_\_\_



8 Work out the perimeter of this rectangle.

[2 marks]

Not drawn accurately

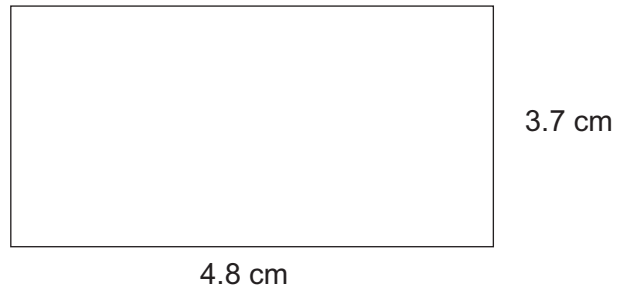

---

---

Answer \_\_\_\_\_ cm



- 9 Work out the shaded area on the centimetre grid.  
State the units of your answer.

[4 marks]

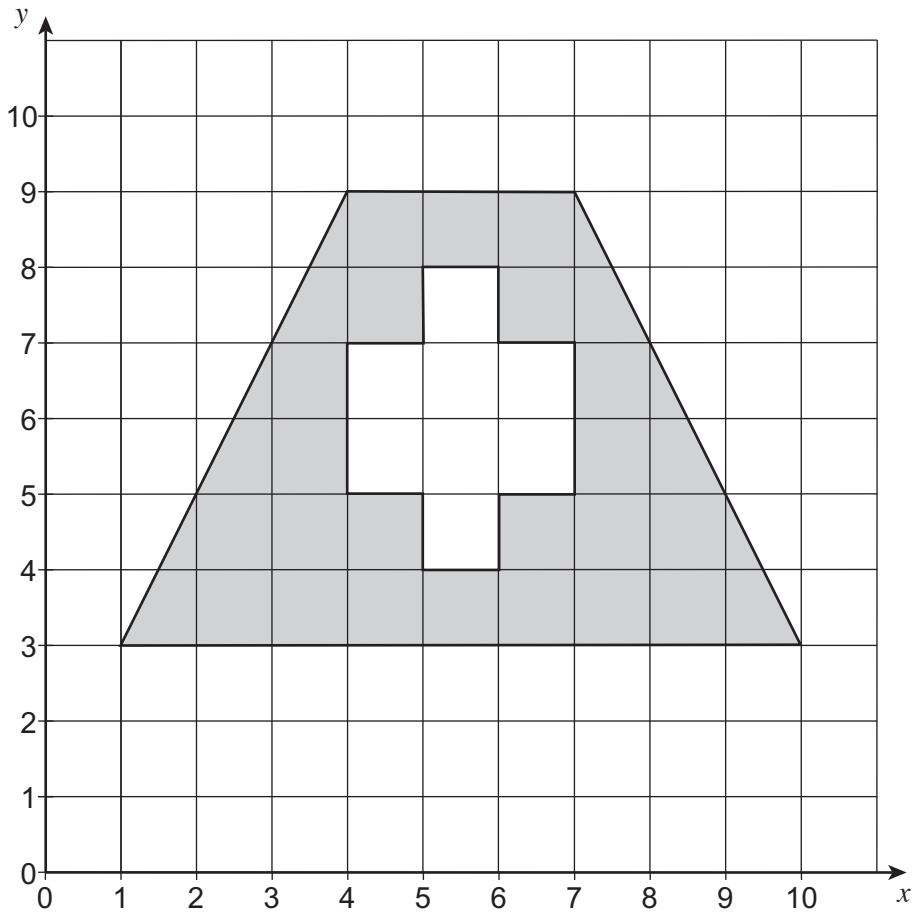

Answer \_\_\_\_\_

Turn over ►



**10** Here are five cards.

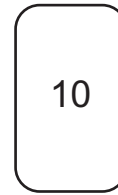
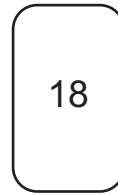
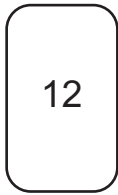

**10 (a)** Write down the range of the numbers.

**[1 mark]**

---

Answer \_\_\_\_\_

**10 (b)** Work out the mean of the numbers.

**[2 marks]**

---

---

Answer \_\_\_\_\_



- 10 (c)** Change the number on one of the cards so that the mean of the five numbers goes down by 2

**[2 marks]**

---

---

Answer

Change

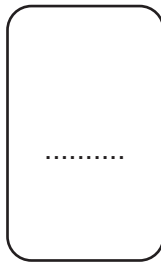

to

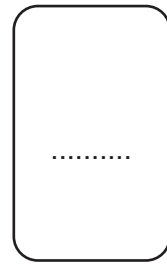

**Turn over for the next question**



- 11** Here is a 4 by 4 magic square.  
Every row, column and diagonal adds up to 34

16	2	3	13
5	11	10	8
9	7	6	12
4	14	15	1

There are other rotational symmetry patterns of four numbers that add up to 34

For example 2, 3, 14 and 15

16	2	3	13
5	11	10	8
9	7	6	12
4	14	15	1

In each part use rotational symmetry to work out and shade **two more** numbers so that the four shaded numbers add up to 34

**11 (a)**

**[1 mark]**

16	2	3	13
5	11	10	8
9	7	6	12
4	14	15	1



11 (b)

[1 mark]

16	2	3	13
5	11	10	8
9	7	6	12
4	14	15	1

11 (c)

[1 mark]

16	2	3	13
5	11	10	8
9	7	6	12
4	14	15	1

Turn over for the next question

Turn over ►



**12** A staircase has 12 steps as shown.

Each step is 19 cm high.

Not drawn accurately

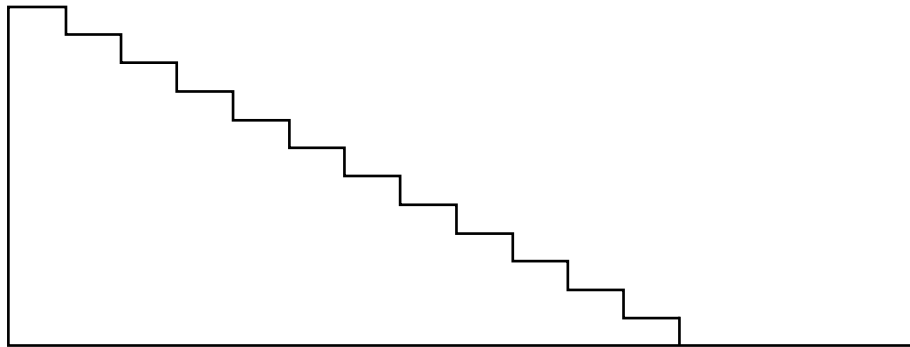

**12 (a)** Work out the height of this staircase.

**[2 marks]**

---

---

Answer \_\_\_\_\_ cm

**12 (b)** A different staircase has identical steps.  
The height of this staircase is 3.04 metres.

Work out the number of steps.

**[3 marks]**

---

---

---

Answer \_\_\_\_\_





- 13 (a)** Work out  $\sqrt{18.4} + 3.1^2$   
Give your answer to 1 decimal place.

**[2 marks]**

---

---

Answer \_\_\_\_\_

- 13 (b)** Work out  $-105 \div 4.2$

**[1 mark]**

---

Answer \_\_\_\_\_

**Turn over for the next question**



**14** A bag contains 20 red counters and 30 blue counters.  
A counter is picked at random.

**14 (a)** What is the probability that the counter is blue? **[1 mark]**

---

Answer \_\_\_\_\_

**14 (b)** The red counters are numbered from 1 to 20  
The blue counters are numbered from 1 to 30  
What is the probability that the counter has the number 10 on it?

**[1 mark]**

---

Answer \_\_\_\_\_

**14 (c)** What is the probability that the counter has a number containing a 2?  
Give your answer as a fraction in its simplest form.

**[3 marks]**

---

---

---

---

---

Answer \_\_\_\_\_



15

This hexagon has two lines of symmetry.

Not drawn accurately

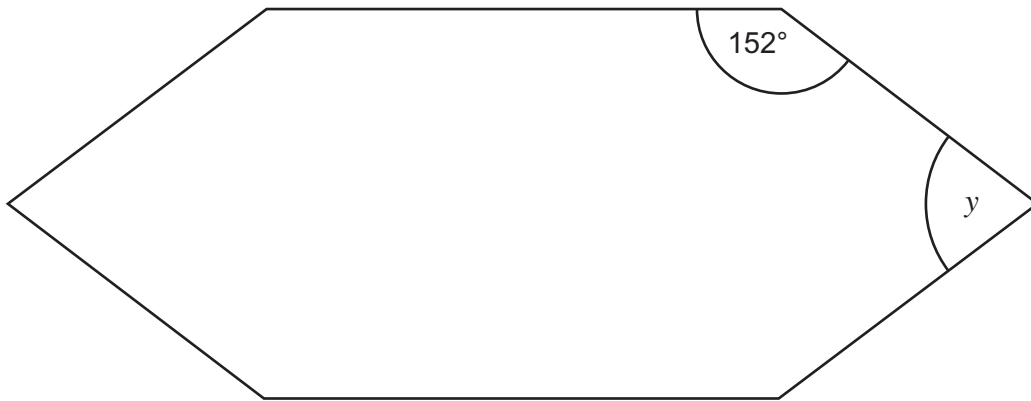
Work out the size of angle  $y$ .**[3 marks]**

---

---

---

---

---

---

Answer \_\_\_\_\_ degrees

**Turn over for the next question**

- 16 (a)** On the grid, enlarge shape *A* by scale factor 2  
Label it *B*.

**[2 marks]**

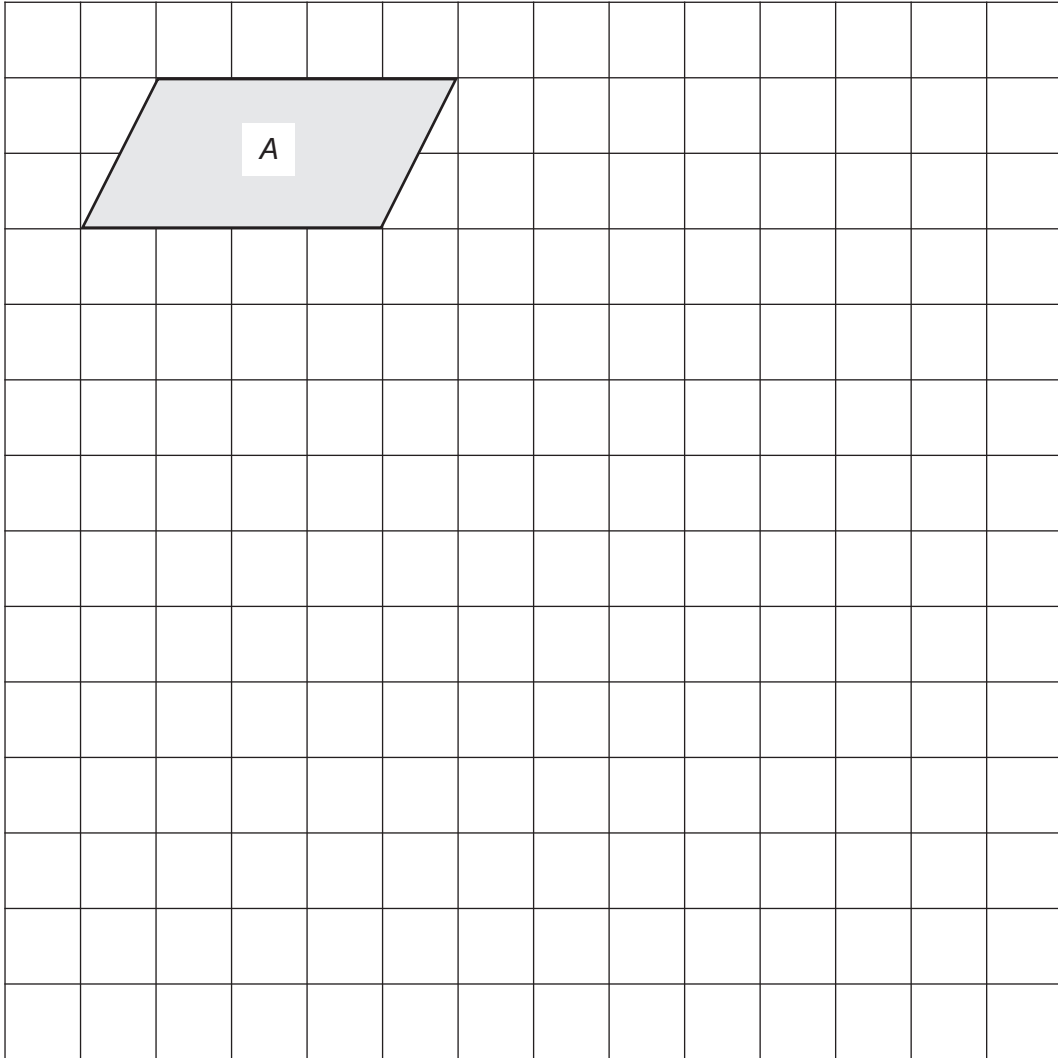

- 16 (b)** How many times bigger is the area of shape *B* than the area of shape *A*?

**[1 mark]**

\_\_\_\_\_

Answer \_\_\_\_\_



16 (c) On this grid, rotate shape A by  $90^\circ$  clockwise about point P.

[3 marks]

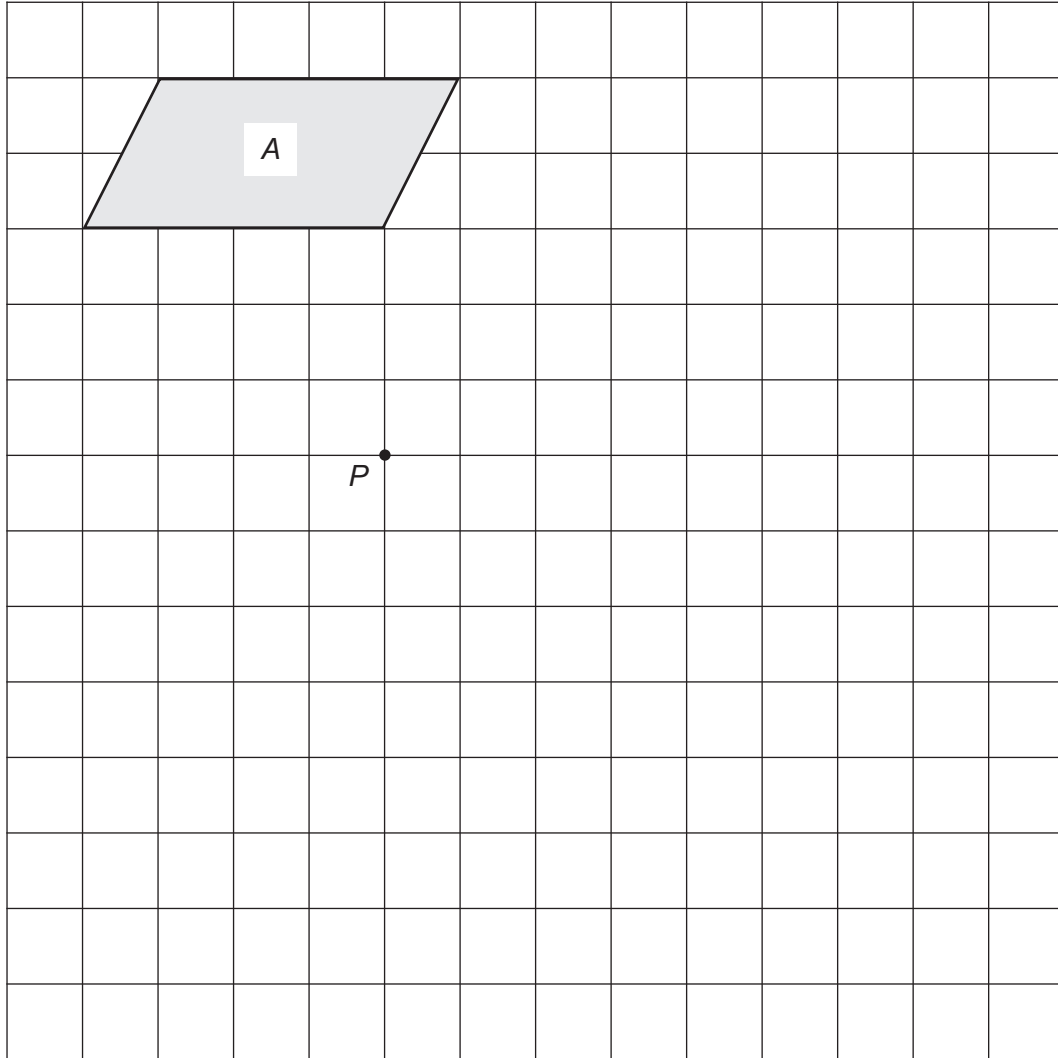

Turn over for the next question



- 17 100 people are asked about their work.  
Here are some of the results.

	Full time	Part time	Not working	Total
Men	24	9		60
Women	18			40
Total	42			100

- 17 (a) The total number working **part time** is the same as the total number of people **not working**.

Complete the table.

[4 marks]



**\*17 (b)** In this survey, there are 60 men and 40 women.

Which is greater

the percentage of the men who work full time

or

the percentage of the women who work full time?

You **must** show your working.

**[3 marks]**

---

---

---

---

---

---

---

Answer \_\_\_\_\_

**Turn over for the next question**



**18** A builder mixes sand and cement in the ratio 4 : 1

**18 (a)** Altogether he mixes 250 kg

How much sand and cement does he use?

**[2 marks]**

---

---

---

Sand \_\_\_\_\_ kg

Cement \_\_\_\_\_ kg

**18 (b)** Cement is sold in 25 kg bags.

Work out the **maximum** amount of mix that the builder can make with 3 bags of cement.

**[3 marks]**

---

---

---

Answer \_\_\_\_\_ kg





19 (a) Complete the table of values for  $y = x^2 - 5$  for values of  $x$  from  $-3$  to  $3$

[2 marks]

$x$	$-3$	$-2$	$-1$	$0$	$1$	$2$	$3$
$y$	$4$		$-4$			$-1$	$4$

19 (b) Draw the graph of  $y = x^2 - 5$  for values of  $x$  from  $-3$  to  $3$

[2 marks]

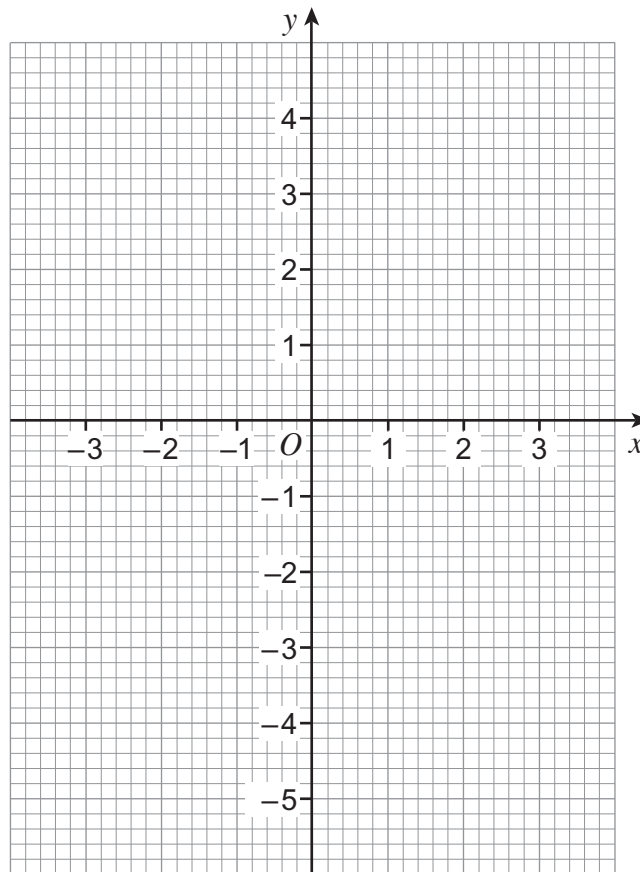

19 (c) Use the graph of  $y = x^2 - 5$  to write down the values of  $x$  when  $y = 0$

[1 mark]

Answer \_\_\_\_\_ and \_\_\_\_\_



**20** The table shows the proportions of left-handed and right-handed students in a school.

	Left-handed	Right-handed
Boys	15%	85%
Girls	12%	88%

**\*20 (a)** 20 boys and 10 girls are chosen at random from the school.

Estimate the number of left-handed students chosen.

**[3 marks]**

---

---

---

Answer \_\_\_\_\_

**20 (b)** There are an equal number of boys and girls in the school.  
A student is chosen at random.

Work out the probability that the student is right-handed.

**[2 marks]**

---

---

Answer \_\_\_\_\_



**21 (a)** Work out the area of a circle of radius 6 cm

**[2 marks]**

---



---

Answer \_\_\_\_\_  $\text{cm}^2$

**21 (b)** Quarter circles of radius 6 cm are cut from the corners of a rectangle as shown.

**[3 marks]**

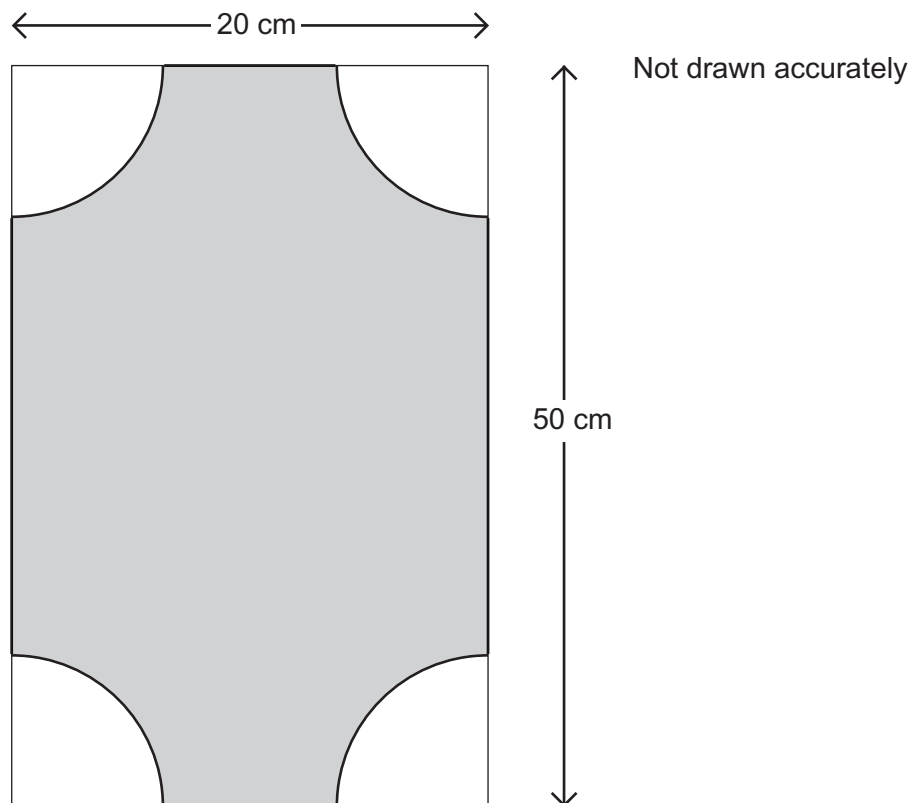

Work out the shaded area.

---



---



---

Answer \_\_\_\_\_  $\text{cm}^2$



22

In 1981 the population of England was 46 million.  
In 2011 the population of England was 53 million.

Work out the increase in population as a percentage of the 1981 figure.

**[3 marks]**

---

---

---

---

Answer \_\_\_\_\_ %



23

The area of the rectangle and the area of the triangle are equal.

Not drawn accurately

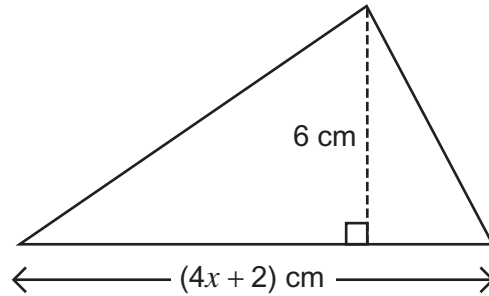
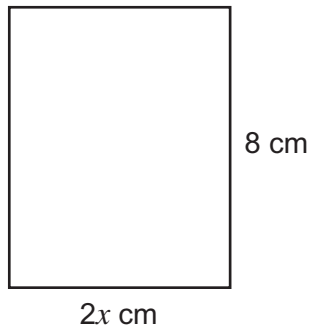
Work out the value of  $x$ .**[4 marks]**

---

---

---

---

---

---

---

 $x =$  \_\_\_\_\_**Turn over for the next question**

7

**Turn over ►**

24

A ladder of length 31 feet is leaning against a wall as shown.  
The foot of the ladder is 8 feet from the wall.  
The wall is 35 feet tall.

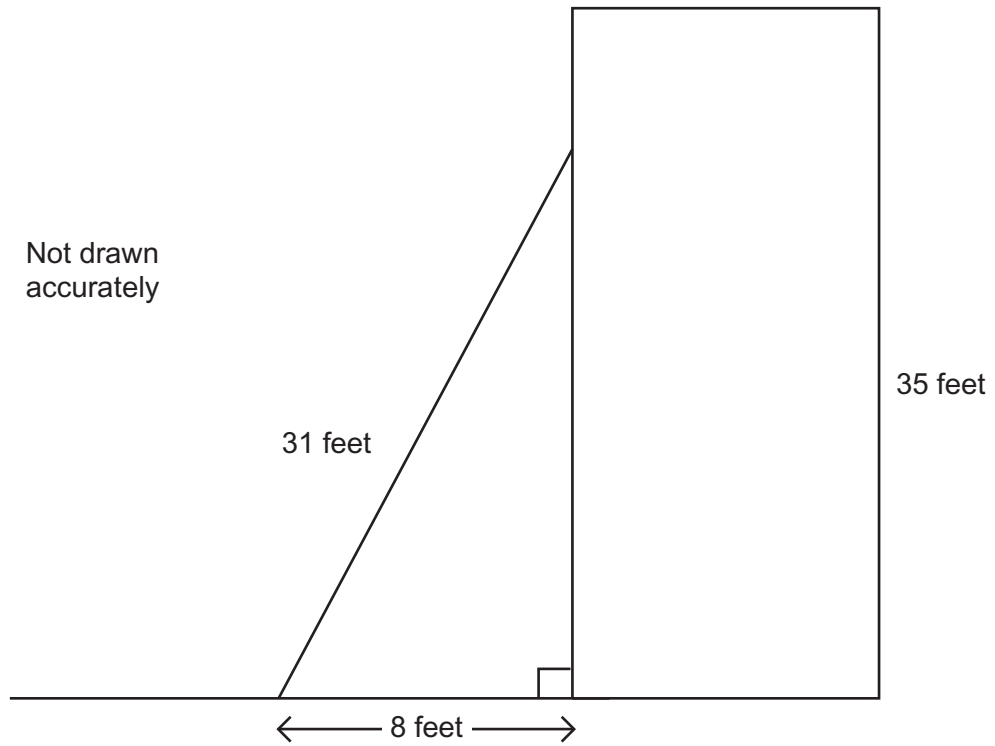

Work out the distance from the top of the ladder to the top of the wall.

[4 marks]

---

---

---

---

---

---

---

---

---

---

Answer \_\_\_\_\_ feet

**END OF QUESTIONS**

4
---



**There are no questions printed on this page**

**DO NOT WRITE ON THIS PAGE  
ANSWER IN THE SPACES PROVIDED**



**There are no questions printed on this page**

**DO NOT WRITE ON THIS PAGE  
ANSWER IN THE SPACES PROVIDED**

**Copyright Information**

For confidentiality purposes, from the November 2015 examination series, acknowledgements of third party copyright material will be published in a separate booklet rather than including them on the examination paper or support materials. This booklet is published after each examination series and is available for free download from [www.aqa.org.uk](http://www.aqa.org.uk) after the live examination series.

Permission to reproduce all copyright material has been applied for. In some cases, efforts to contact copyright-holders may have been unsuccessful and AQA will be happy to rectify any omissions of acknowledgements. If you have any queries please contact the Copyright Team, AQA, Stag Hill House, Guildford, GU2 7XJ.

Copyright © 2016 AQA and its licensors. All rights reserved.

