

Please write clearly in block capitals.

Centre number

--	--	--	--	--

Candidate number

--	--	--	--

Surname

Forename(s)

Candidate signature

GCSE MATHEMATICS (LINEAR)

H

Higher Tier Paper 1

Wednesday 2 November 2016 Morning Time allowed: 1 hour 30 minutes

Materials

For this paper you must have:

- mathematical instruments.

You must **not** use a calculator.



Instructions

- Use black ink or black ball-point pen. Draw diagrams in pencil.
- Answer **all** questions.
- You must answer the questions in the spaces provided. Do not write outside the box around each page or on blank pages.
- Do all rough work in this book.

Information

- The marks for questions are shown in brackets.
- The maximum mark for this paper is 70.
- The quality of your written communication is specifically assessed in Questions 6, 7 and 21. These questions are indicated with an asterisk (*).
- You may ask for more answer paper, tracing paper and graph paper. These must be tagged securely to this answer book.

Advice

- In all calculations, show clearly how you work out your answer.



Formulae Sheet: Higher Tier

Area of trapezium = $\frac{1}{2}(a+b)h$

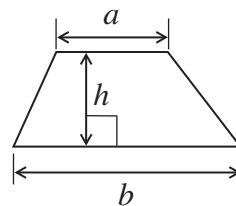

Volume of prism = area of cross section \times length

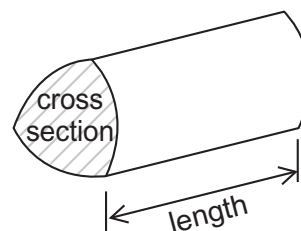

Volume of sphere = $\frac{4}{3}\pi r^3$

Surface area of sphere = $4\pi r^2$

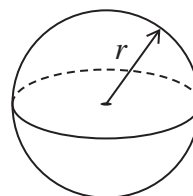

Volume of cone = $\frac{1}{3}\pi r^2 h$

Curved surface area of cone = $\pi r l$

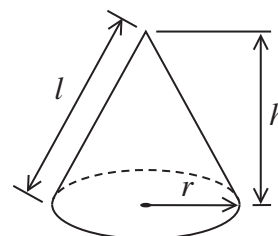

In any triangle ABC

Area of triangle = $\frac{1}{2}ab \sin C$

Sine rule $\frac{a}{\sin A} = \frac{b}{\sin B} = \frac{c}{\sin C}$

Cosine rule $a^2 = b^2 + c^2 - 2bc \cos A$

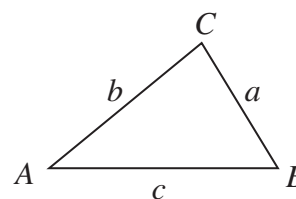

The Quadratic Equation

The solutions of $ax^2 + bx + c = 0$, where $a \neq 0$, are given by

$$x = \frac{-b \pm \sqrt{b^2 - 4ac}}{2a}$$



Answer **all** questions in the spaces provided.

1 Solve $5w - 3 = 3w + 15$

[3 marks]

$w =$ _____

2 A spinner has four sections A, B, C and D.
The table shows the probabilities of the spinner landing on A, B or C.

Outcome	A	B	C	D
Probability	0.2	0.3	0.15	

Work out the probability of landing on D.

[2 marks]

Answer _____



3 Here is a straight-line graph.

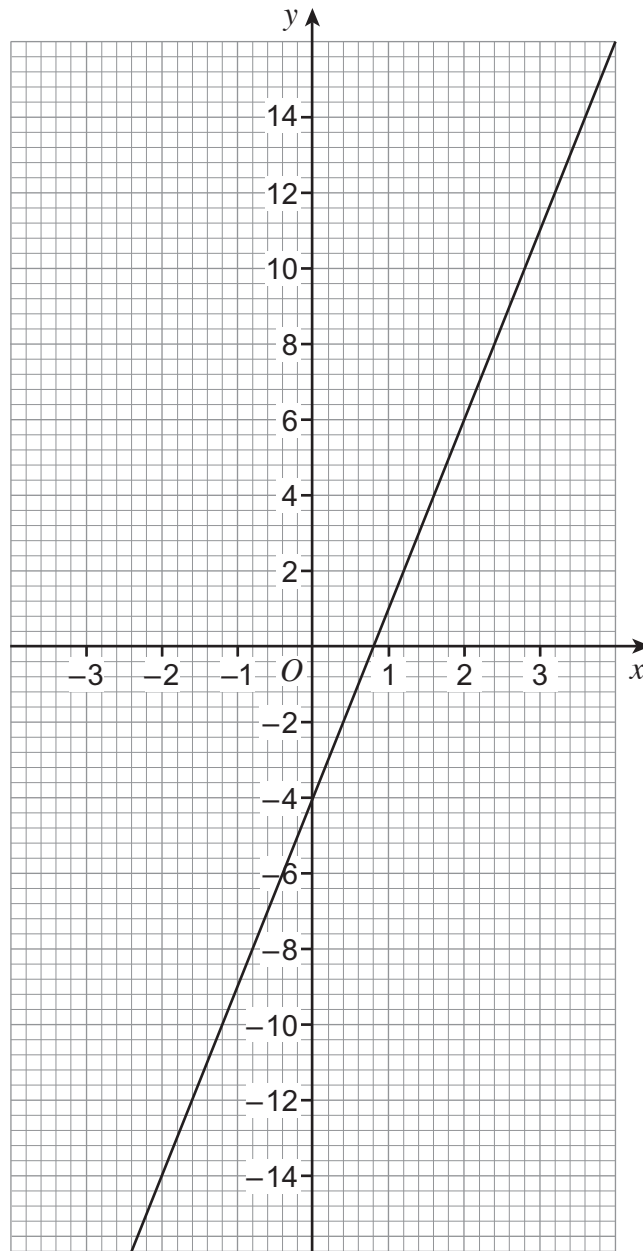

3 (a) Use the graph to work out the value of x when $y = 8$

[1 mark]

Answer _____



3 (b) Work out the gradient of the line.

[3 marks]

Answer _____

4 Expand and simplify $6(x - 3) - 4(x - 5)$

[3 marks]

Answer _____

Turn over for the next question

7

Turn over ►



5 Draw a diagram to show this data.

Height, h , (cm)	Frequency
$5 < h \leq 10$	4
$10 < h \leq 15$	9
$15 < h \leq 20$	12
$20 < h \leq 25$	5

[3 marks]

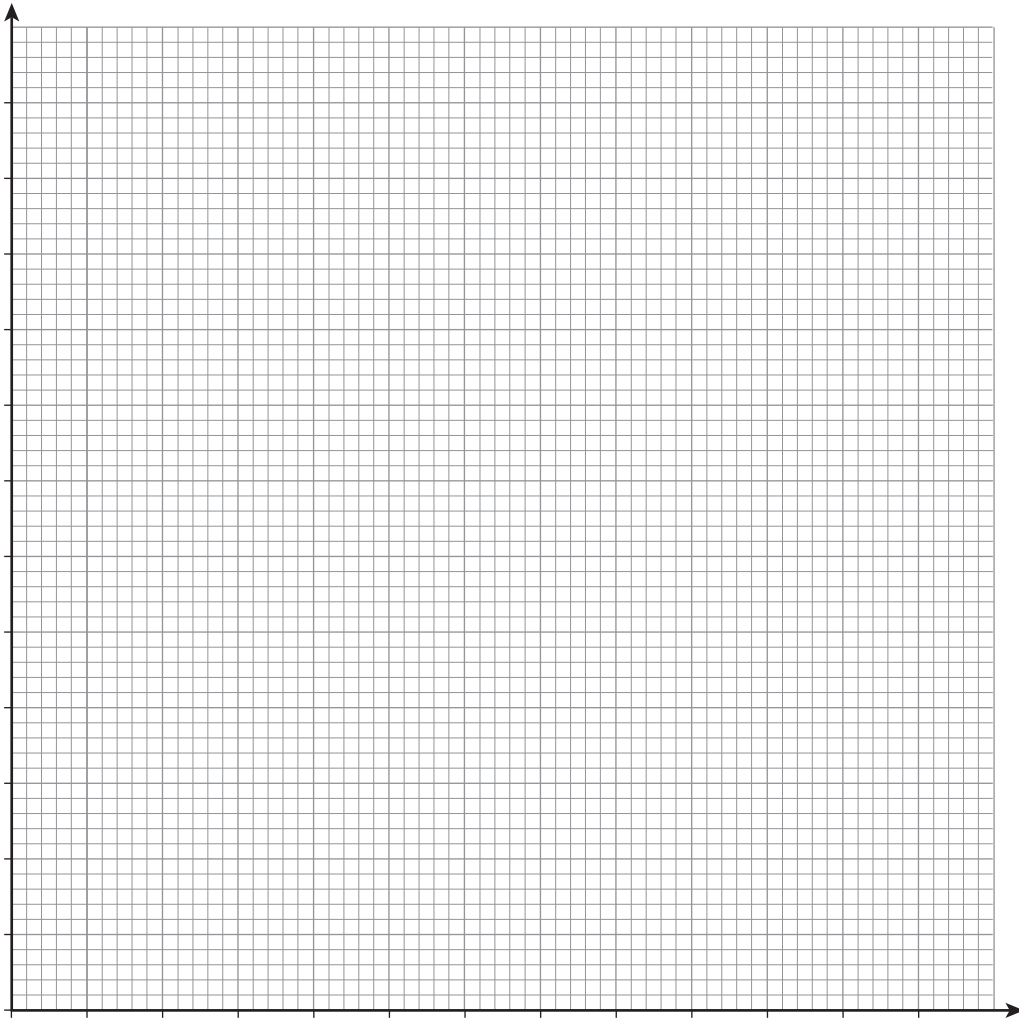

*6 Here is a drink container and a lunch box.

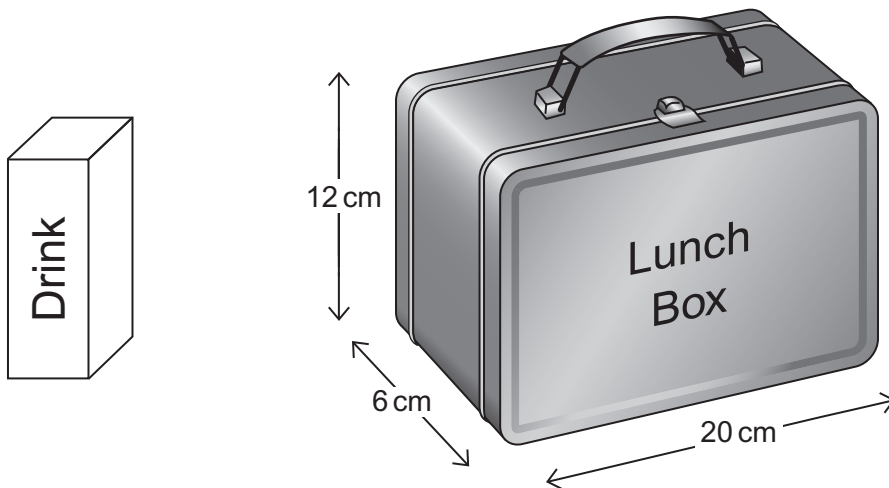

The drink container is a cuboid with a square base.
The area of the base = 25 cm^2
The volume of the container = 400 cm^3

Will the container fit inside the lunch box?
You **must** show your working.

[4 marks]



*7

A parallelogram $ABCD$ and a triangle DCE are joined as shown.
 BCE is a straight line.

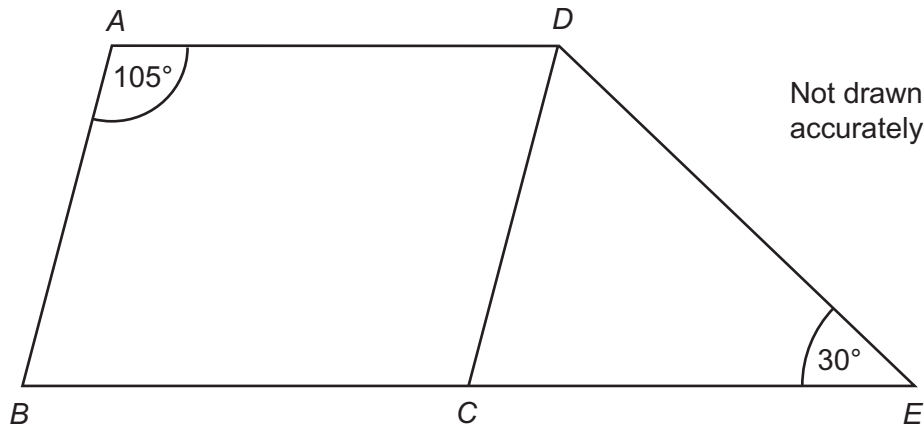

Show that DCE is an isosceles triangle.
 You **must** show your working.

[4 marks]



- 8 Field A is a rectangle with sides of 30 m and 70 m
Field B is a square with the same **perimeter** as Field A.



How much bigger in area is Field B than Field A?
You **must** show your working.

[4 marks]

Answer _____ m²

Turn over for the next question



9 Here are the first five terms of a linear sequence.

9 15 21 27 33 ...

Work out the n th term.

[2 marks]

Answer _____

10 Factorise $x^2 - 100$

[1 mark]

Answer _____



- 11 (a)** Work out $2 \times 10^6 \times 8 \times 10^4$
Give your answer in standard form.

[2 marks]

Answer _____

- 11 (b)** Work out $\frac{2 \times 10^6}{8 \times 10^4}$
Give your answer as an ordinary number.

[2 marks]

Answer _____

Turn over for the next question



12 Solve $2x + 3 + \frac{4x - 1}{2} = 10$

Do **not** use trial and improvement.

[4 marks]

$x =$ _____



13 A park ranger wants to estimate the number of fish in a lake.

She catches 400 fish.

She marks them with ink and puts them back in the lake.

The next day she catches 60 fish.

There are 3 marked with ink.

The ranger says,

“There are about 8000 fish in the lake.”

Show that she is correct.

[3 marks]

Turn over for the next question

7

Turn over ►



14

The pie charts show the eye colour of some students.

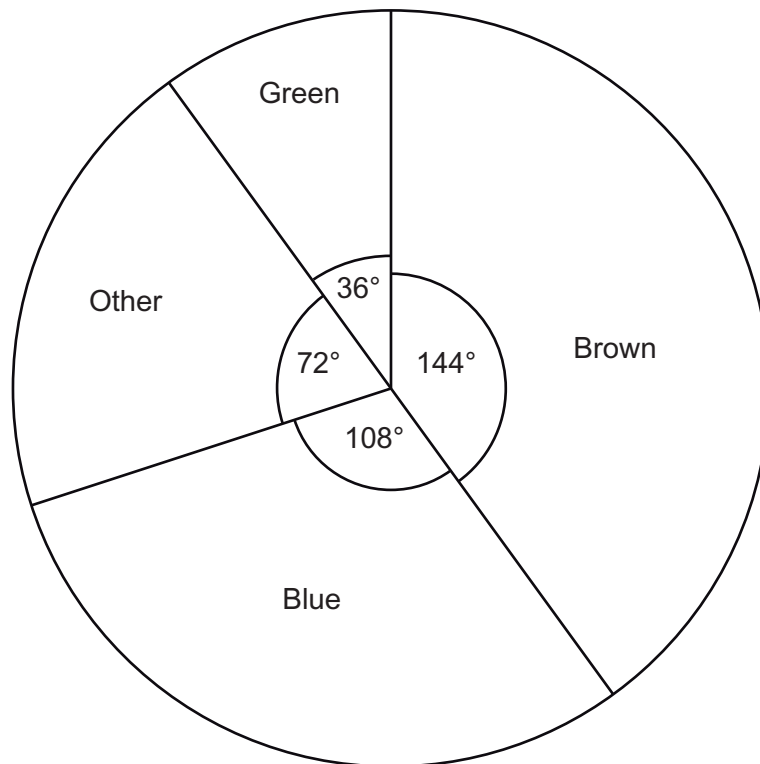
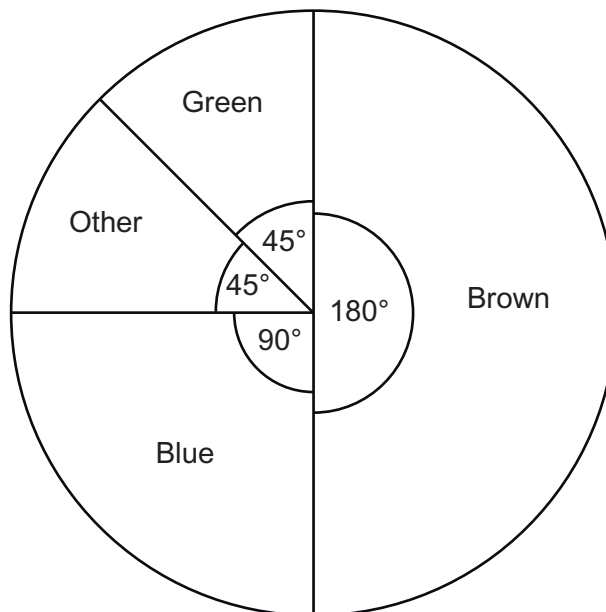
Girls**Boys**

The areas of the pie charts are proportional to the number of students.

The radius of the girls' pie chart is 5 cm
The radius of the boys' pie chart is 4 cm

5 girls have green eyes.

How many boys and girls altogether have blue eyes?

[5 marks]

Answer _____

Turn over for the next question

5

Turn over ►



- 15** A headteacher wants to do a survey of students in years 9, 10 and 11
The table shows the number of students in each year.

Year	9	10	11
Number in year	235	215	250

She wants to take a sample of 70 students, stratified by year group.

Complete the table below to show the number of students in each year she should sample.

[3 marks]

Year	9	10	11
Number in year	235	215	250
Sample size			



16 Work out $64^{\frac{2}{3}}$ [2 marks]

Answer _____

17 Show that $(\sqrt{3} + \sqrt{75})^2 = 108$ [2 marks]

Turn over for the next question

7

Turn over ►



18 Show that $\frac{2}{x-3} + \frac{1}{x-1} = 1$

simplifies to $x^2 - 7x + 8 = 0$

[3 marks]



- 19 The area of this rectangle is 8 cm^2

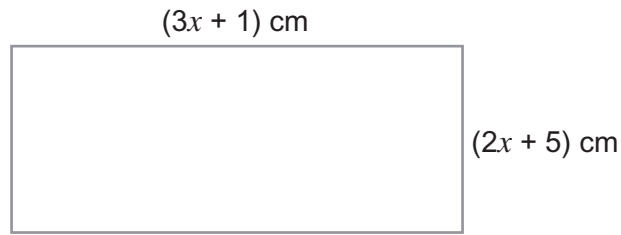

Not drawn
accurately

Work out the value of x .

[4 marks]

Answer _____

Turn over for the next question

7

Turn over ►



- 20 (a)** O is the centre of the circle.
Work out the size of angle a .

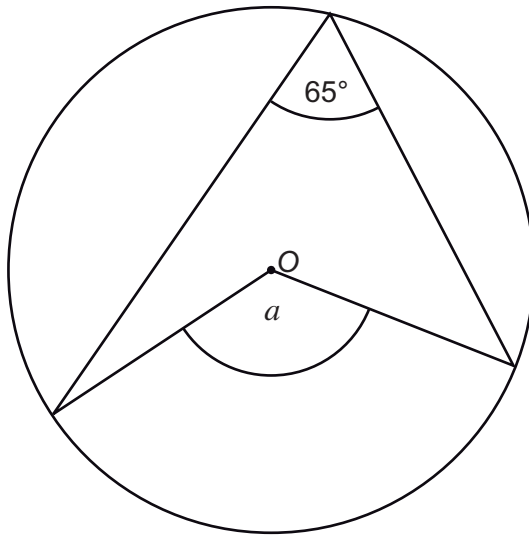

Not drawn
accurately

Circle your answer.

[1 mark]

115°

130°

135°

295°

- 20 (b)** Work out the size of angle b .

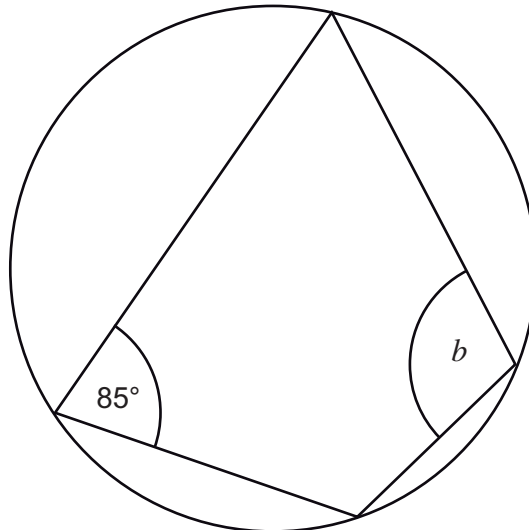

Not drawn
accurately

Circle your answer.

[1 mark]

85°

90°

95°

115°



20 (c) $ABCD$ are points on the circumference of a circle centre O .

$$\text{Angle } BCD = 130^\circ$$

$$\text{Angle } ABC = 105^\circ$$

$$\text{Angle } OBC = \text{Angle } ODC$$

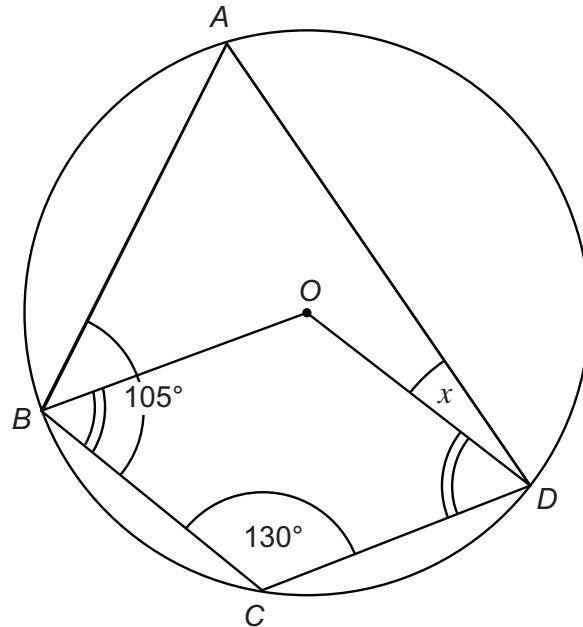

Not drawn
accurately

Work out the size of angle ADO , marked x on the diagram.
You **must** show your working which may be on the diagram.

[4 marks]

Answer _____ degrees



- *21 This shape is made from two identical sectors.

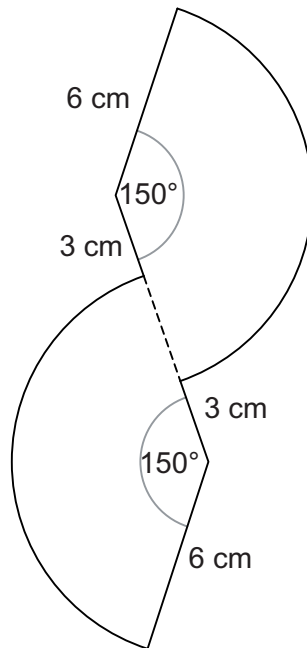

Not drawn
accurately

Work out the perimeter of the shape.
Give your answer in terms of π .

[4 marks]

Answer _____ cm

END OF QUESTIONS



There are no questions printed on this page

**DO NOT WRITE ON THIS PAGE
ANSWER IN THE SPACES PROVIDED**



There are no questions printed on this page

**DO NOT WRITE ON THIS PAGE
ANSWER IN THE SPACES PROVIDED**

Copyright Information

For confidentiality purposes, from the November 2015 examination series, acknowledgements of third party copyright material will be published in a separate booklet rather than including them on the examination paper or support materials. This booklet is published after each examination series and is available for free download from www.aqa.org.uk after the live examination series.

Permission to reproduce all copyright material has been applied for. In some cases, efforts to contact copyright-holders may have been unsuccessful and AQA will be happy to rectify any omissions of acknowledgements. If you have any queries please contact the Copyright Team, AQA, Stag Hill House, Guildford, GU2 7XJ.

Copyright © 2016 AQA and its licensors. All rights reserved.

