

Write your name here

Surname

Other names

Pearson
Edexcel GCSE

Centre Number

--	--	--	--	--

Candidate Number

--	--	--	--

Mathematics B

Unit 2: Number, Algebra, Geometry 1
(Non-Calculator)

Foundation Tier

Thursday 4 June 2015 – Morning
Time: 1 hour 15 minutes

Paper Reference

5MB2F/01

You must have: Ruler graduated in centimetres and millimetres, protractor, pair of compasses, pen, HB pencil, eraser. Tracing paper may be used.

Total Marks



Instructions

- Use **black** ink or ball-point pen.
- **Fill in the boxes** at the top of this page with your name, centre number and candidate number.
- Answer **all** questions.
- Answer the questions in the spaces provided – *there may be more space than you need.*
- **Calculators must not be used.**

Information

- The total mark for this paper is 60
- The marks for **each** question are shown in brackets – *use this as a guide as to how much time to spend on each question.*
- Questions labelled with an **asterisk** (*) are ones where the quality of your written communication will be assessed.

Advice

- Read each question carefully before you start to answer it.
- Keep an eye on the time.
- Try to answer every question.
- Check your answers if you have time at the end.

Turn over ►

P44789A

©2015 Pearson Education Ltd.

6/6/6/



PEARSON

GCSE Mathematics 2MB01

Formulae: Foundation Tier

**You must not write on this formulae page.
Anything you write on this formulae page will gain NO credit.**

Area of trapezium = $\frac{1}{2}(a + b)h$

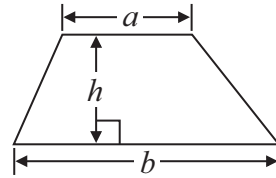

Volume of prism = area of cross section \times length

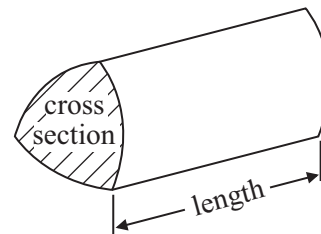

Answer ALL questions.

Write your answers in the spaces provided.

You must write down all stages in your working.

You must NOT use a calculator.

1 (a) Work out $17.2 + 25.8$

.....
(1)

(b) Work out $\frac{1}{4} \times 60$

.....
(1)

(c) Write down the value of the 3 in 18.35

.....
(1)

(Total for Question 1 is 3 marks)



2 Here is an equilateral triangle.

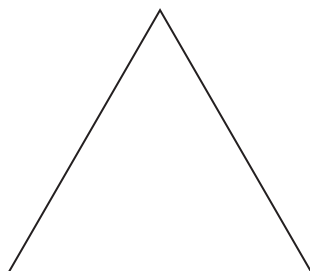

(a) Write down the order of rotational symmetry of the triangle.

.....
(1)

Here is a solid prism.

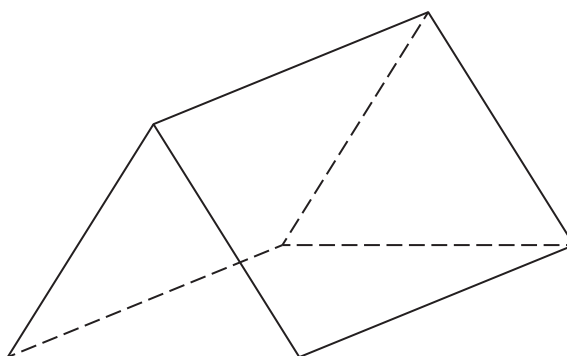

(b) (i) Write down the number of faces of the prism.

(ii) Write down the number of edges of the prism.

.....
(2)

(Total for Question 2 is 3 marks)



3 (a) Shade $\frac{3}{4}$ of this shape.

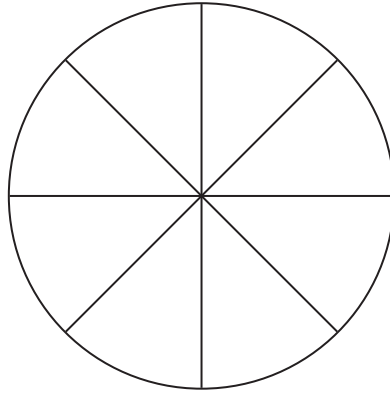

(1)

*(b) Which has the greater value 0.3 or $\frac{1}{3}$?

Give a reason for your answer.

(2)

(Total for Question 3 is 3 marks)

4 Jodie has 40 eggs.

She wants to put all the eggs into boxes.
She can put 6 eggs into each box.

Find the smallest number of boxes Jodie needs.
You must show your working.

(Total for Question 4 is 2 marks)



5 Here is a solid prism.

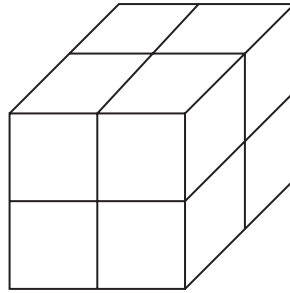

Diagram **NOT**
accurately drawn

The prism is made from centimetre cubes.

(a) Write down the volume of the prism.

.....cm³
(1)

Here is a centimetre grid.

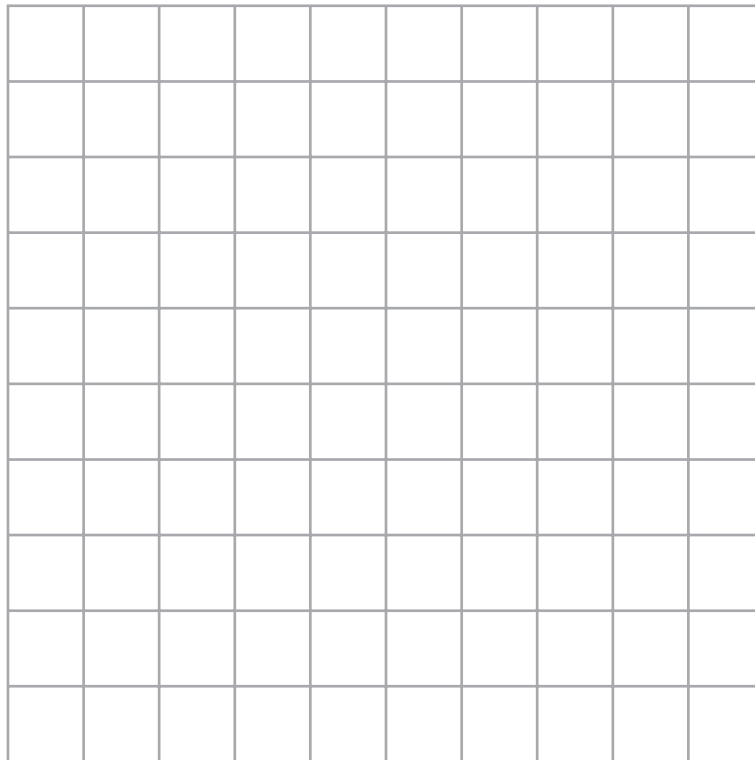

(b) On the grid, draw a rectangle with an area of 12 cm².

(2)

(Total for Question 5 is 3 marks)



***6** Kerry uses sticky tape to fasten parcels.

She uses 15 cm of sticky tape to fasten each parcel.

Kerry needs to fasten 25 parcels.

She has 300 cm of sticky tape.

Does Kerry have enough sticky tape to fasten all the parcels?

You must show your working.

(Total for Question 6 is 3 marks)



7 The diagram shows a circle and two straight lines.

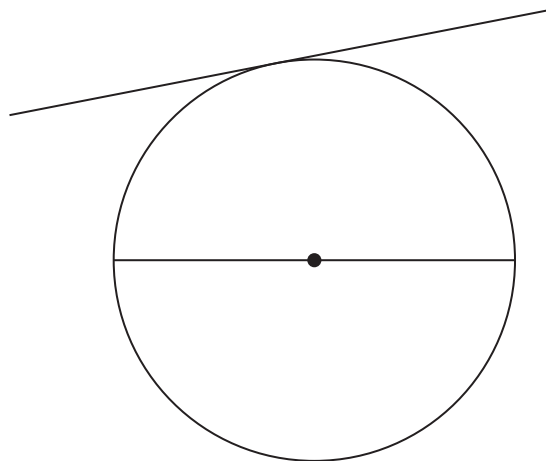

The straight line inside the circle goes through the centre of the circle.

(a) Write down the mathematical name of this straight line.

.....
(1)

The straight line outside the circle touches the circle at one point.

(b) Write down the mathematical name of this straight line.

.....
(1)

Here is a circle centre O .

(c) In the circle, draw a sector of the circle.

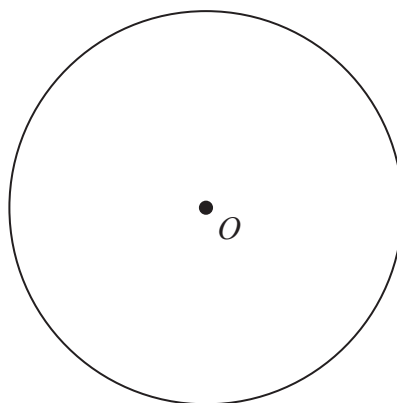

(1)

(Total for Question 7 is 3 marks)



8 A quadrilateral is drawn on the grid.

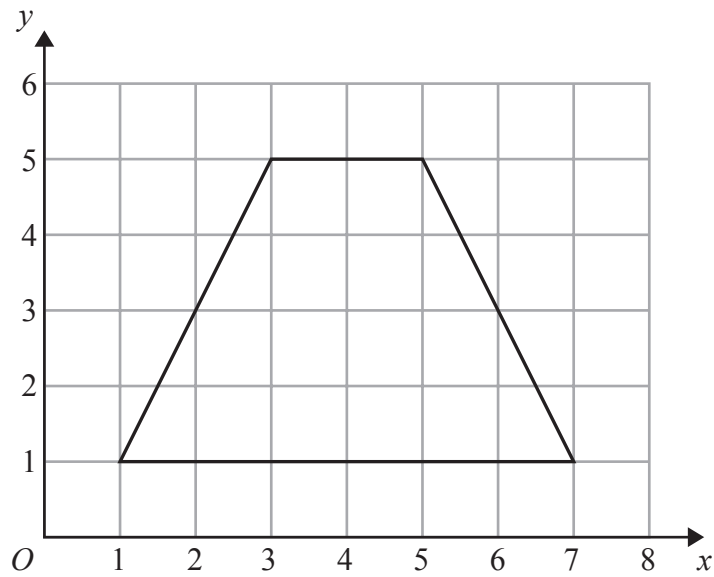

(a) Write down the mathematical name of this quadrilateral.

.....
(1)

(b) On the grid, draw the line of symmetry of the quadrilateral.

(1)

(c) On the grid, mark with a cross (×) the point (3, 4).

Label this point *P*.

(1)

(Total for Question 8 is 3 marks)



9 Penelope is going to cook a chicken.

She uses this rule to find the cooking time.

$$\text{cooking time} = 20 \text{ minutes for each } 0.5 \text{ kg} + 10 \text{ minutes}$$

The chicken has a weight of 2 kg.

Penelope wants to finish cooking the chicken at 12 30 pm.

What time should Penelope start cooking the chicken?

.....
(Total for Question 9 is 4 marks)

10 (i) Write down the next two terms in this number sequence.

100 95 90 85

(ii) Explain how you got your answer.

.....
.....
(Total for Question 10 is 2 marks)



11 (a) Work out 30% of 60

.....
(2)

(b) Work out $-15 \div -3$

.....
(1)

(c) Work out the value of $4 + 3 \times (9 - 2)$

.....
(1)

(Total for Question 11 is 4 marks)



12 (a) Simplify $4ab - 3ab$

.....
(1)

(b) Simplify $x^2 + x^2 + x^2$

.....
(1)

(c) Simplify $3x - 2y + x - 3y$

.....
(2)

(Total for Question 12 is 4 marks)



13 The diagram shows a cuboid.

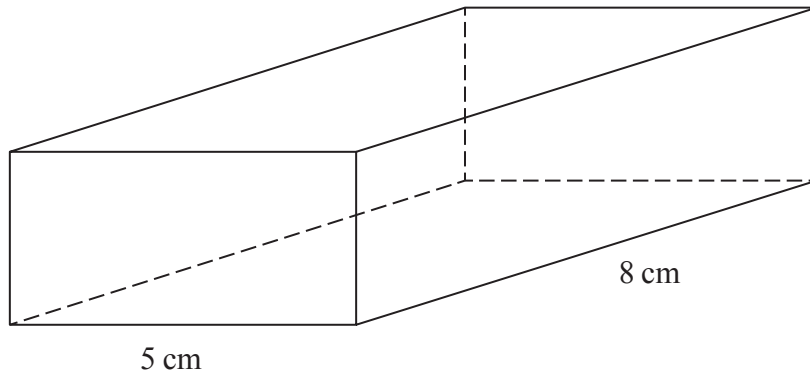

Diagram **NOT** accurately drawn

The width of the cuboid is 5 cm.

The length of the cuboid is 8 cm.

The volume of the cuboid is 120 cm^3 .

Work out the height of the cuboid.

..... cm

(Total for Question 13 is 2 marks)



14 Here is a graph you can use to change between metres and feet.

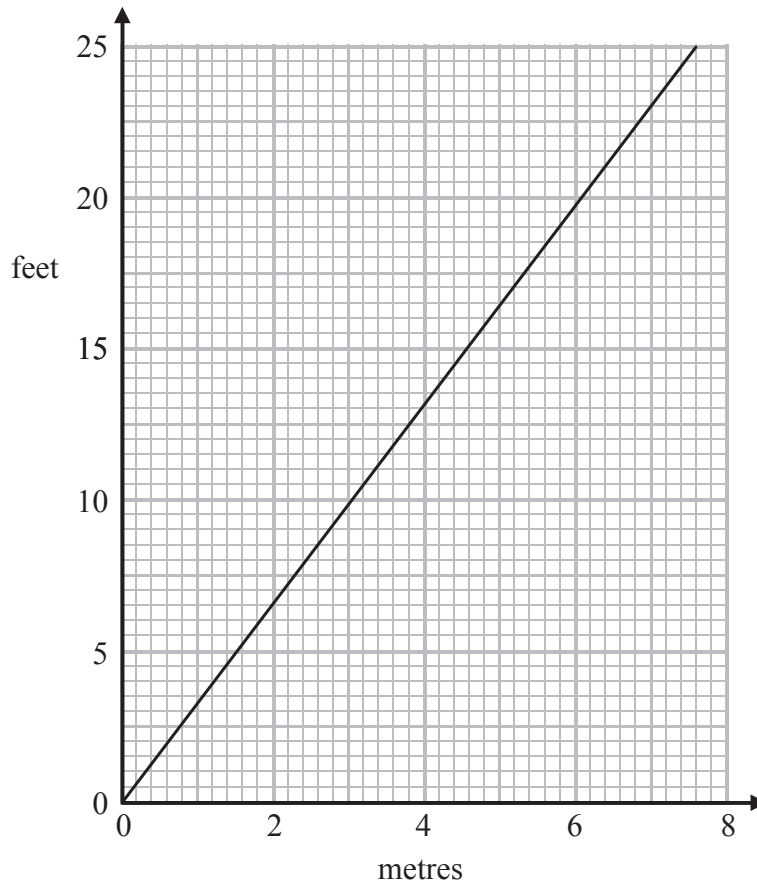

An American space rocket is 360 feet tall.
A European space rocket is 50 metres tall.

The American space rocket is taller than the European space rocket.

How much taller?

You must show your working.

(Total for Question 14 is 3 marks)



*15

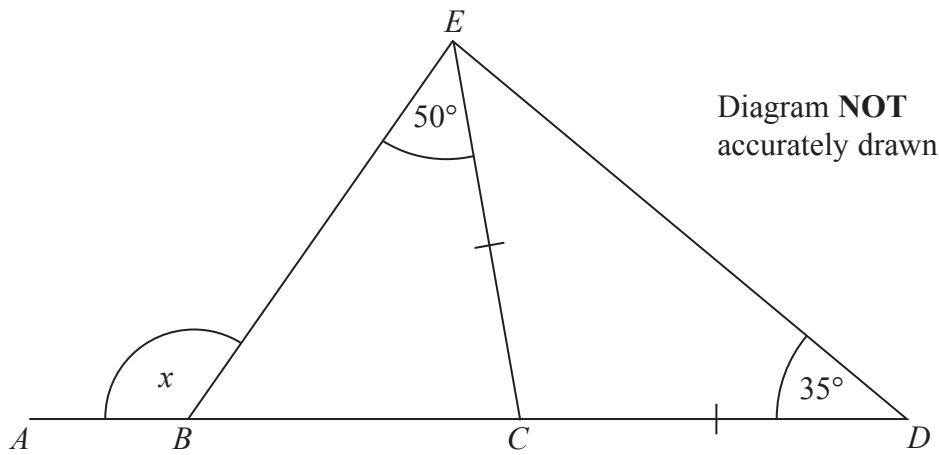

$ABCD$ is a straight line.

$CE = CD$

Angle $BEC = 50^\circ$

Angle $CDE = 35^\circ$

Work out the size of the angle marked x .

You must give reasons for your answer.

(Total for Question 15 is 4 marks)



P 4 4 7 8 9 A 0 1 5 2 0

*16 Paperclips are sold in boxes.

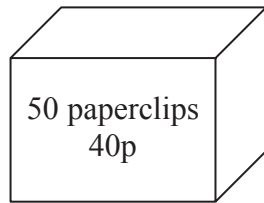

Small box

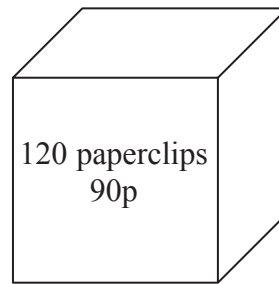

Large box

A small box has 50 paperclips and costs 40p.
A large box has 120 paperclips and costs 90p.

Which box is the better value for money?
You must show your working.

(Total for Question 16 is 3 marks)



17 (a) Factorise fully $6xy + 18xy^2$

.....
(2)

(b) Simplify $\frac{w^6}{w^3}$

.....
(1)

(c) Simplify $(a^4)^5$

.....
(1)

(Total for Question 17 is 4 marks)



18 The diagram shows a rectangular floor.

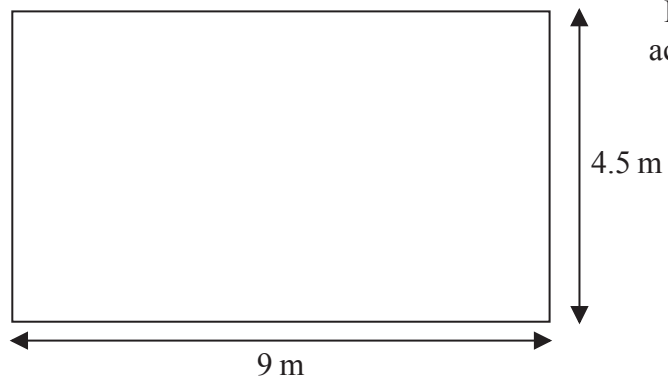

Diagram **NOT**
accurately drawn

Toji is going to cover the floor with floor boards.
Each floor board is 0.1 m wide and 1.5 m long.

Work out the smallest number of floor boards Toji needs.

(Total for Question 18 is 3 marks)



19 Gary's motorbike uses petrol.

Gary needs to mix oil with the petrol.
He mixes oil and petrol in the ratio 1 : 14 by volume.

Gary is going to ride his motorbike 3000 miles.
Each 20 miles he rides uses 1 litre of the oil and petrol mixture.

A 500 ml bottle of oil costs £3.99

Work out the total cost of the bottles of oil Gary needs to buy.
(1 litre = 1000 ml)

You must show all your working.

£

(Total for Question 19 is 4 marks)

TOTAL FOR PAPER IS 60 MARKS



BLANK PAGE

