

Centre Number						Candidate Number				
Surname										
Other Names										
Candidate Signature										

For Examiner's Use	
Examiner's Initials	
Question	Mark
1	
2	
3	
4	
5	
6	
TOTAL	



General Certificate of Secondary Education  
Higher Tier  
June 2013

## Additional Science

Unit Physics P2

## Physics

Unit Physics P2

PH2HP

H

Thursday 23 May 2013 9.00 am to 10.00 am

**For this paper you must have:**

- a ruler
- a calculator
- the Physics Equations Sheet (enclosed).

**Time allowed**

- 1 hour

**Instructions**

- Use black ink or black ball-point pen.
- Fill in the boxes at the top of this page.
- Answer **all** questions.
- You must answer the questions in the spaces provided. Do not write outside the box around each page or on blank pages.
- Do all rough work in this book. Cross through any work you do not want to be marked.

**Information**

- The marks for questions are shown in brackets.
- The maximum mark for this paper is 60.
- You are expected to use a calculator where appropriate.
- You are reminded of the need for good English and clear presentation in your answers.
- Question 2 (b) should be answered in continuous prose. In this question you will be marked on your ability to:
  - use good English
  - organise information clearly
  - use specialist vocabulary where appropriate.

**Advice**

- In all calculations, show clearly how you work out your answer.



J U N 1 3 P H 2 H P 0 1

G/K91104 6/6/6/6

PH2HP

Answer **all** questions in the spaces provided.

- 1** The diagram shows a boat pulling a water skier.

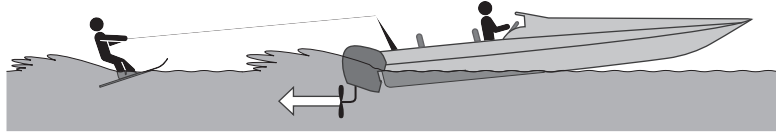

- 1 (a)** The arrow represents the force on the water produced by the engine propeller. This force causes the boat to move.

Explain why.

.....

.....

.....

.....

(2 marks)

- 1 (b)** The boat accelerates at a constant rate in a straight line. This causes the velocity of the water skier to increase from 4.0 m/s to 16.0 m/s in 8.0 seconds.

- 1 (b) (i)** Calculate the acceleration of the water skier and give the unit.

Use the correct equation from the Physics Equations Sheet.

.....

.....

.....

Acceleration = .....

(3 marks)



1 (b) (ii) The water skier has a mass of 68 kg.

Calculate the resultant force acting on the water skier while accelerating.

Use the correct equation from the Physics Equations Sheet.

.....  
.....  
.....

Resultant force = ..... N  
(2 marks)

1 (b) (iii) Draw a ring around the correct answer to complete the sentence.

The force from the boat pulling the water skier forwards

will be 

less than
the same as
greater than

 the answer to part (b)(ii).

Give the reason for your answer.

.....  
.....

(2 marks)

9

Turn over for the next question

Turn over ►



**2 (a)** The diagram shows the circuit used to obtain the data needed to plot the current–potential difference graph for a filament bulb.

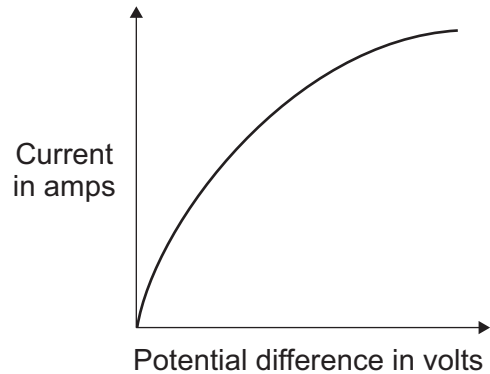
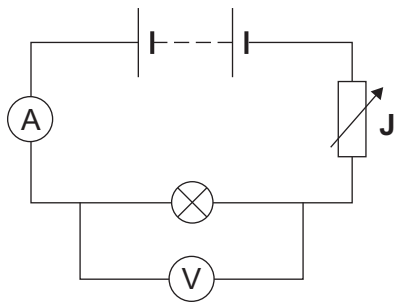

**2 (a) (i)** Why is the component labelled 'J' included in the circuit?

.....  
 .....

(1 mark)

**2 (a) (ii)** The resistance of the bulb increases as the potential difference across the bulb increases. Why?

.....  
 .....

(1 mark)

**2 (a) (iii)** The bulb is at full brightness when the potential difference across the bulb is 12V. The current through the bulb is then 3A.

Calculate the power of the bulb when it is at full brightness and give the unit.

Use the correct equation from the Physics Equations Sheet.

.....  
 .....

Power = .....

(3 marks)



**2 (b)** *In this question you will be assessed on using good English, organising information clearly and using specialist terms where appropriate.*

The table gives data about two types of light bulb people may use in their homes.

Type of light bulb	Energy efficiency	Cost of one light bulb	Average lifetime in hours
Halogen	10%	£1.95	2 000
Light Emitting Diode (LED)	32%	£11.70	36 000

Both types of light bulb produce the same amount of light.

Evaluate, in terms of cost and energy efficiency, the use of the two types of light bulb.

To gain full marks you must compare both types of light bulb and conclude which light bulb would be the best to use.

.....

.....

.....

.....

.....

.....

.....

.....

.....

.....

.....

.....

.....

.....

.....

.....

.....

.....

.....

.....

.....

(6 marks)

11

Turn over ▶



3 (a) Nuclear power stations generate about 14% of the world's electricity.

3 (a) (i) Uranium-235 is used as a fuel in some nuclear reactors.

Name **one** other substance used as a fuel in some nuclear reactors.

.....

(1 mark)

3 (a) (ii) Energy is released from nuclear fuels by the process of nuclear fission.  
This energy is used to generate electricity.

Describe how this energy is used to generate electricity.

Do **not** explain the nuclear fission process.

.....  
.....  
.....  
.....  
.....  
.....

(3 marks)

3 (b) The diagram shows the nuclear fission process for an atom of uranium-235.

Complete the diagram to show how the fission process starts a chain reaction.

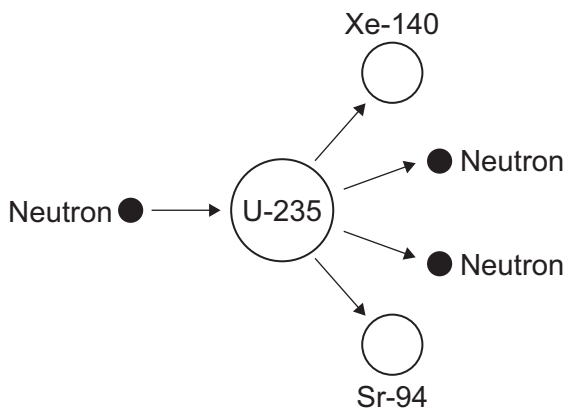

(2 marks)



3 (c) The diagram shows the cross-section through a nuclear reactor.

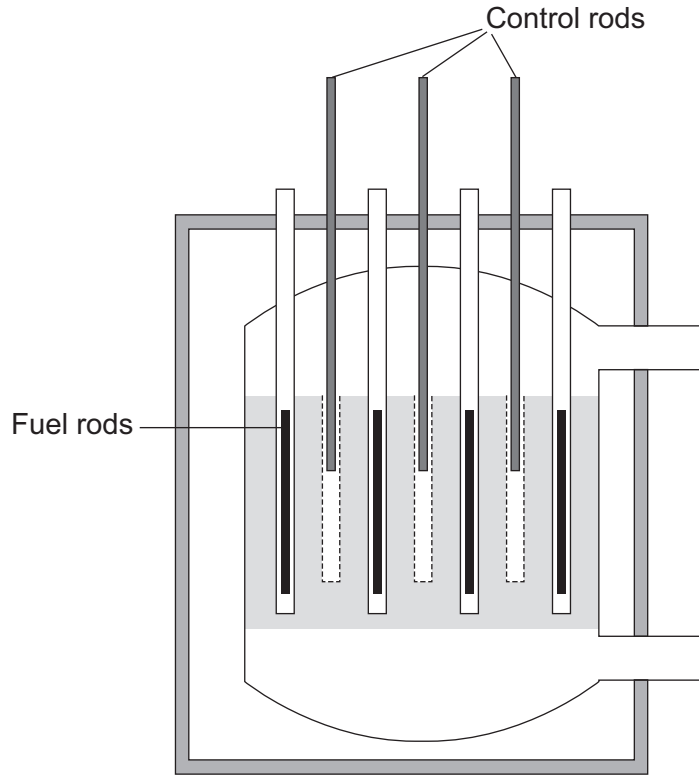

The control rods, made from boron, are used to control the chain reaction. Boron atoms absorb neutrons without undergoing nuclear fission.

Why does lowering the control rods reduce the amount of energy released each second from the nuclear fuel?

.....

.....

.....

.....

(2 marks)

8
---

Turn over ►



4 (a) The stopping distance of a vehicle is made up of two parts, the thinking distance and the braking distance.

4 (a) (i) What is meant by *thinking distance*?

.....  
.....

(1 mark)

4 (a) (ii) State **two** factors that affect thinking distance.

1 .....

2 .....

(2 marks)

4 (b) A car is travelling at a speed of 20 m/s when the driver applies the brakes. The car decelerates at a constant rate and stops.

4 (b) (i) The mass of the car and driver is 1600 kg.

Calculate the kinetic energy of the car and driver before the brakes are applied.

Use the correct equation from the Physics Equations Sheet.

.....  
.....  
.....

Kinetic energy = ..... J  
(2 marks)

4 (b) (ii) How much work is done by the braking force to stop the car and driver?

Work done = ..... J  
(1 mark)





4 (b) (iii) The braking force used to stop the car and driver was 8000 N.

Calculate the braking distance of the car.

Use the correct equation from the Physics Equations Sheet.

.....  
.....  
.....  
.....

Braking distance = ..... m  
(2 marks)

4 (b) (iv) The braking distance of a car depends on the speed of the car and the braking force applied.

State **one** other factor that affects braking distance.

.....  
.....

(1 mark)

4 (b) (v) Applying the brakes of the car causes the temperature of the brakes to increase.

Explain why.

.....  
.....  
.....  
.....

(2 marks)

**Question 4 continues on the next page**

**Turn over ▶**



**4 (c)** Hybrid cars have an electric engine and a petrol engine. This type of car is often fitted with a regenerative braking system. A regenerative braking system not only slows a car down but at the same time causes a generator to charge the car's battery.

State and explain the benefit of a hybrid car being fitted with a regenerative braking system.

.....

.....

.....

.....

.....

.....

(3 marks)

<b>14</b>



**5** In 2011 an earthquake caused severe damage to a nuclear power station in Japan. The damage led to the release of large amounts of radioactive iodine-131 ( $^{131}_{53}\text{I}$ ) into the atmosphere.

**5 (a)** The table gives some information about an atom of iodine-131 ( $^{131}_{53}\text{I}$ ).

Complete the table.

mass number	131
number of protons	53
number of neutrons	

(1 mark)

**5 (b)** Complete the sentence.

The number of protons in an atom is called the proton number or the ..... number.

(1 mark)

**5 (c)** An atom of iodine-131 decays into an atom of xenon (Xe) by emitting a beta particle.

**5 (c) (i)** The decay of iodine-131 can be represented by the equation below.

Complete the equation by writing the correct number in each of the **two** boxes.

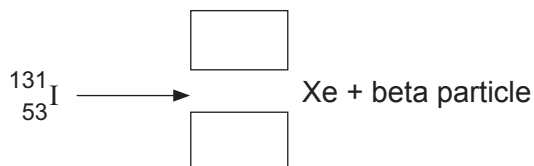

(2 marks)

**Question 5 continues on the next page**

**Turn over ►**



**5 (c) (ii)** A sample of rainwater contaminated with iodine-131 gives a count rate of 1200 counts per second.

Calculate how many days it will take for the count rate from the sample of rainwater to fall to 75 counts per second.

Half-life of iodine-131 = 8 days

Show clearly how you work out your answer.

.....  
.....

..... days  
(2 marks)

**5 (c) (iii)** If people drink water contaminated with iodine-131, the iodine-131 builds up in the thyroid gland. This continues until the thyroid is saturated with iodine-131 and cannot absorb any more. The radiation emitted from the iodine-131 could cause cancer of the thyroid.

In Japan, people likely to be drinking water contaminated with iodine-131 were advised to take tablets containing a non-radioactive isotope of iodine.

Suggest why this advice was given.

.....  
.....  
.....  
.....

(2 marks)

8
---



- 6 The picture shows an electric cooker hob. The simplified circuit diagram shows how the four heating elements connect to the mains electricity supply. The heating elements are identical.

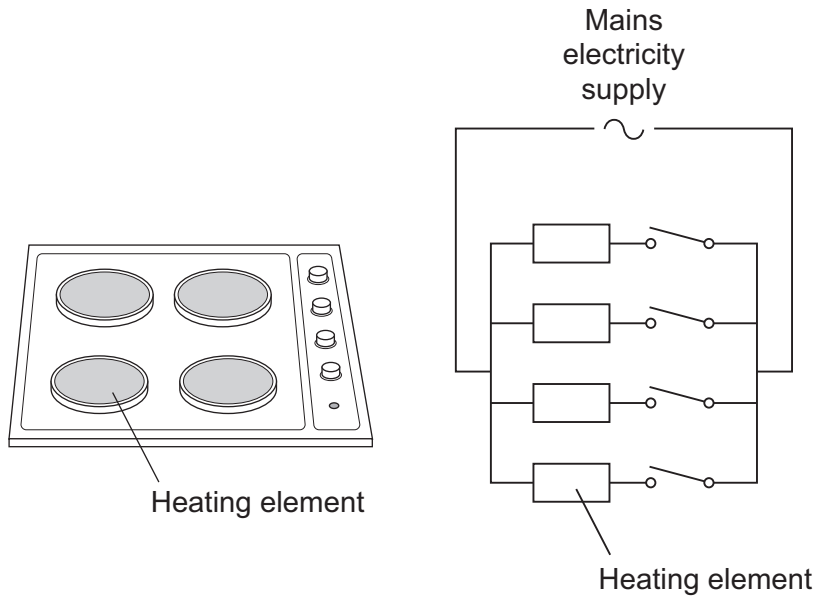

When all four heating elements are switched on at full power the hob draws a current of 26A from the 230V mains electricity supply.

- 6 (a) Calculate the resistance of one heating element when the hob is switched on at full power.

Use the correct equation from the Physics Equations Sheet.

Give your answer to 2 significant figures.

.....

.....

.....

Resistance = .....  $\Omega$   
(3 marks)

Question 6 continues on the next page

Turn over ►



6 (b) The table gives the maximum current that can safely pass through copper wires of different cross-sectional area.

Cross-sectional area in mm <sup>2</sup>	Maximum safe current in amps
1.0	11.5
2.5	20.0
4.0	27.0
6.0	34.0

6 (b) (i) The power sockets in a home are wired to the mains electricity supply using cables containing 2.5 mm<sup>2</sup> copper wires. Most electrical appliances are connected to the mains electricity supply by plugging them into a standard power socket.

It would **not** be safe to connect the electric cooker hob to the mains electricity supply by plugging it into a standard power socket.

Why?

.....

.....

.....

.....

(2 marks)

6 (b) (ii) Describe the structure of the cable that should be used to connect the electric cooker hob to the mains electricity supply.

.....

.....

.....

.....

.....

.....

.....

.....

(3 marks)



**6 (c)** Mains electricity is an alternating current supply. Batteries supply a direct current.

What is the difference between an alternating current and a direct current?

.....

.....

.....

.....

(2 marks)

10
----

**END OF QUESTIONS**



**There are no questions printed on this page**

**DO NOT WRITE ON THIS PAGE  
ANSWER IN THE SPACES PROVIDED**

