

## GCSE (9–1) Mathematics

J560/02 Paper 2 (Foundation Tier)

**Thursday 8 June 2017 – Morning**

**Time allowed: 1 hour 30 minutes**

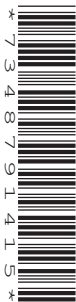

**You may use:**

- Geometrical instruments
- Tracing paper

**Do not use:**

- A calculator



First name									
Last name									
Centre number						Candidate number			

### INSTRUCTIONS

- Use black ink. You may use an HB pencil for graphs and diagrams.
- Complete the boxes above with your name, centre number and candidate number.
- Answer **all** the questions.
- Read each question carefully before you start to write your answer.
- Where appropriate, your answers should be supported with working. Marks may be given for a correct method even if the answer is incorrect.
- Write your answer to each question in the space provided.
- Additional paper may be used if required but you must clearly show your candidate number, centre number and question number(s).
- Do **not** write in the barcodes.

### INFORMATION

- The total mark for this paper is **100**
- The marks for each question are shown in brackets [ ].
- This document consists of **20** pages.

Answer **all** the questions.

1 George recorded all the different types of tree in a wood.

(a) His results are shown in this table.

Complete the table.

Type of tree	Tally	Frequency
Alder		8
Beech		15
Oak		18
Rowan		
Other		13

[2]

(b) Complete the bar chart to show George's results.

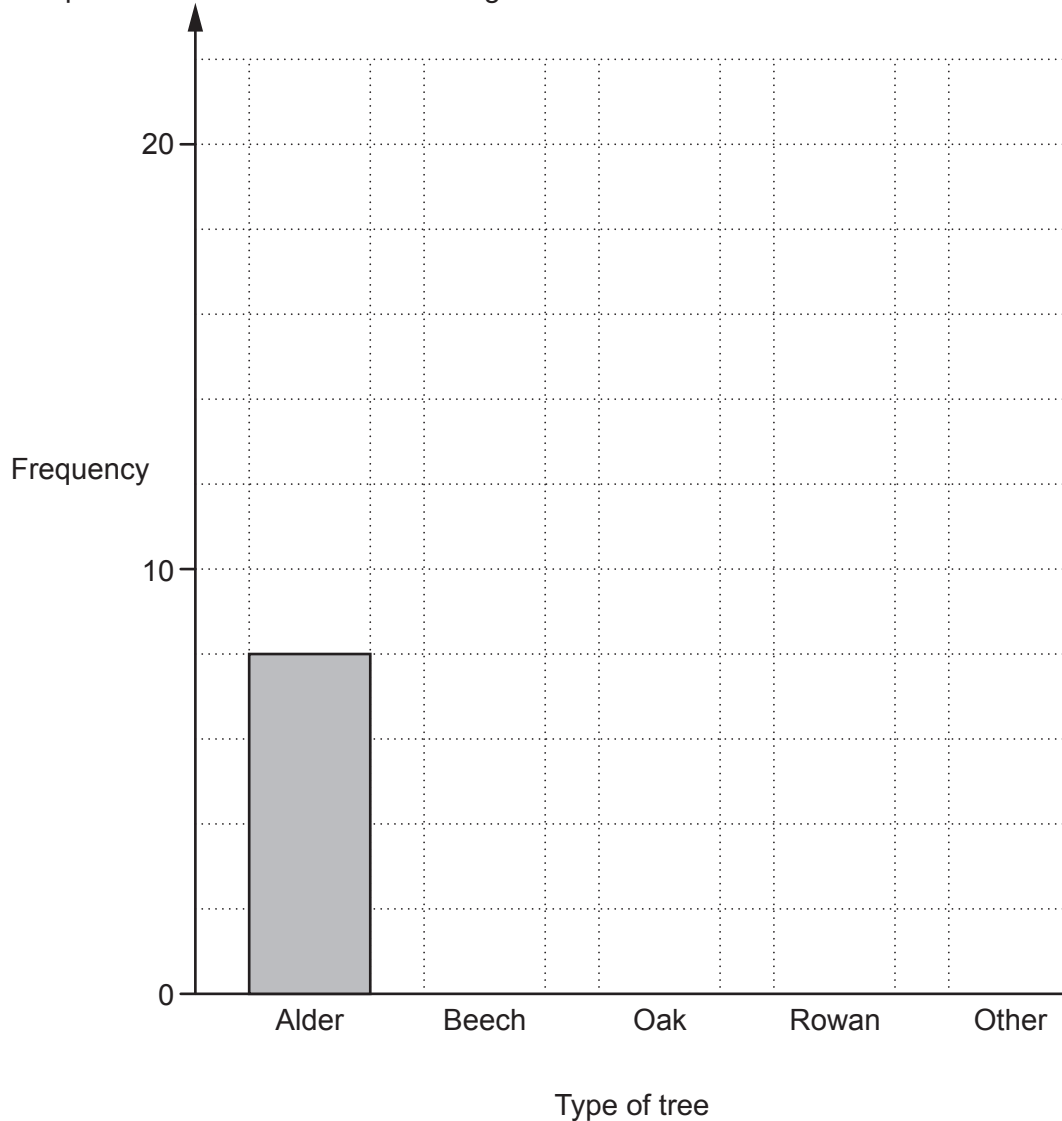

[2]

(c) George found 60 trees altogether in the wood.

What percentage of the trees were oak trees?

(c) ..... % [2]

2 (a) Work out.

(i)  $6\frac{1}{2} + \frac{3}{4}$

(a)(i) ..... [1]

(ii)  $\frac{4}{7}$  of 63

(ii) ..... [2]

(b) Show that  $\frac{4}{5}$  is bigger than  $\frac{7}{9}$ .

.....  
..... [2]

(c) Find a fraction which is bigger than  $\frac{1}{5}$  and smaller than  $\frac{1}{4}$ .

(c) ..... [2]

- 3 (a) Nathan works out  $23 \times 12.4$  without a calculator.

This is Nathan's working.

$10 \times 12.4 = 12.40$ $20 \times 12.4 = 24.80$ $3 \times 12.4 = 37.2$ $23 \times 12.4 = 24.80 + 37.2 = 62$
---

Nathan's working is incorrect.

Explain the error that Nathan has made and work out the correct answer.

.....

.....

..... [3]

- (b) Four friends buy cinema tickets using this offer.

<p><b>Cinema tickets</b></p> <p>Buy 3 tickets and get a ticket <b>free</b></p>
--

They **each** pay £6.45.

How much does a ticket cost?

(b) £ ..... [3]

4 A and B are two farms on this map.

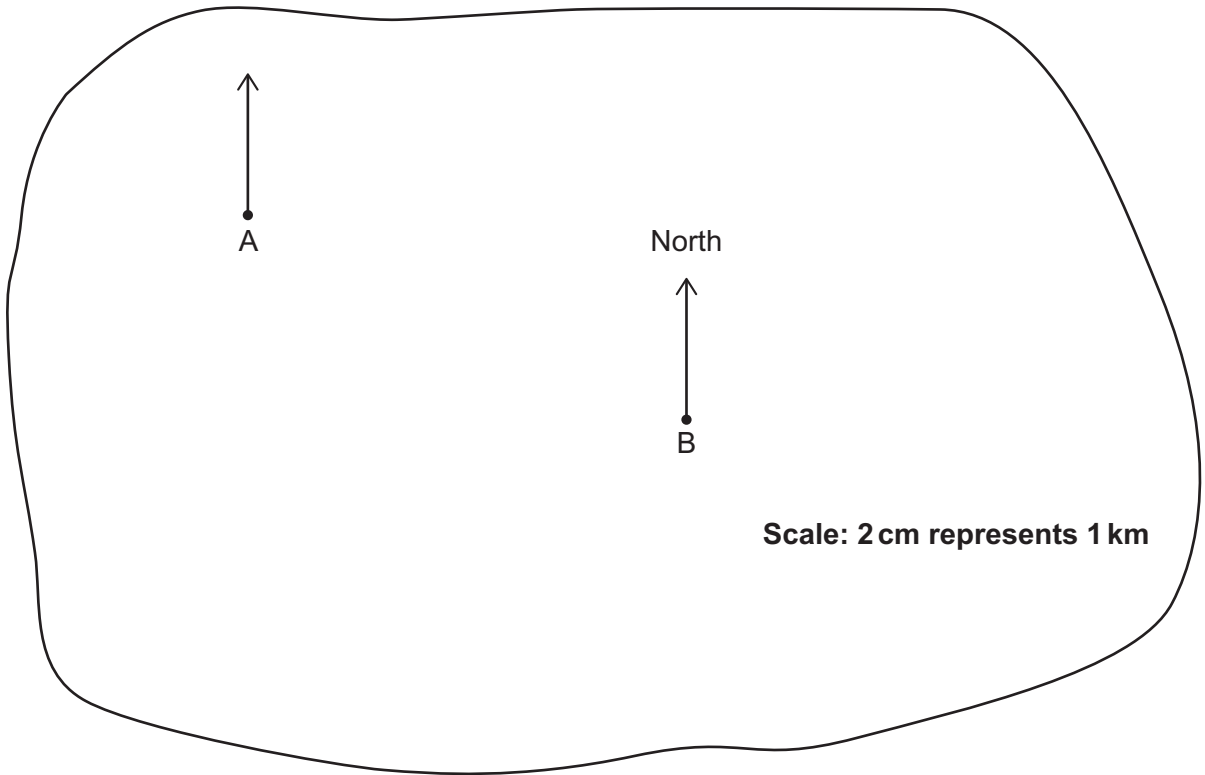

Use the map to complete these sentences.

(a) (i) The distance from A to B is ..... km. [2]

(ii) The bearing of B from A is ..... °. [1]

(b) C is another farm.  
C is 2.5 km from B on a bearing of 230°.

Mark and label the position of C on the map with a cross. [2]

5 (a) Multiply out.

$$3x(x + 2y)$$

(a) ..... [2]

(b) Solve.

(i)  $7x = 28$

(b)(i)  $x =$  ..... [1]

(ii)  $\frac{x}{3} - 2 = 9$

(ii)  $x =$  ..... [2]

- 6 XY and BD are parallel lines.  
 X is a point on AB and C is a point on BD.  
 $XB = XC$ .

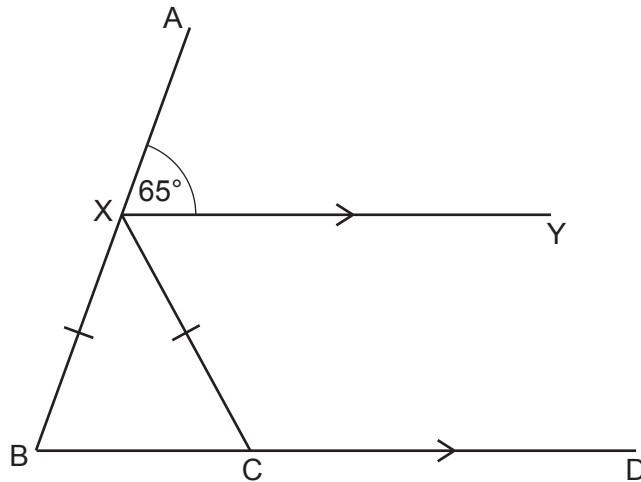

Not to scale

- (a) Complete this sentence.

Angle  $XBC = 65^\circ$  because ..... [1]

- (b) Work out angle  $BXC$ .  
 Give a reason for each angle you work out.

(b) .....  $^\circ$  [4]

- 7 There are **20 coins** in a pot.  
The coins are 1p, 2p, 5p and 10p.

A coin is taken at random from the pot.

- The probability that it is a 1p coin is  $\frac{3}{10}$ .
- The probability that it is a 2p coin is  $\frac{2}{5}$ .

The total value of the coins in the pot is 57 pence.

Work out how many of each type of coin there are in the pot.

1p ..... , 2p ..... , 5p ..... , 10p ..... [4]



8 (a) Evaluate.

(i)  $\sqrt{121}$

(a)(i) ..... [1]

(ii)  $4^{-2}$

(ii) ..... [1]

(b) Work out.

$(9 - 3 \times 2)^2$

(b) ..... [2]

(c) Fill in the power.

$5^{\boxed{\phantom{000}}} = 125$

[1]

9 Lillian works 7 hours each day for 5 days a week. She earns £420 each week.

(a) How much does she earn per hour?

(a) £ ..... [3]

(b) Lillian decides that she is going to work 7 hours each day for **only 4 days** a week. Her earnings are to be reduced by 20%. Lillian thinks that this reduction is reasonable.

(i) Explain why a reduction of 20% is reasonable.

.....  
..... [1]

(ii) How much will Lillian earn working 4 days a week?

(b)(ii) £ ..... [2]

- 10 A square is divided into three rectangles, **A**, **B** and **C**.

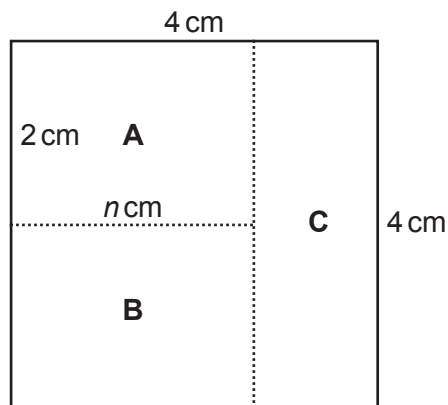

Not to scale

Rectangle **A** has length  $n$  cm and a width of 2 cm.  
 Rectangle **C** has length 4 cm.

- (a) (i) Write down an algebraic expression for the width of rectangle **C**.

(a)(i) ..... cm [1]

- (ii) Write down an algebraic expression for the **area** of rectangle **A**.

(ii) ..... cm<sup>2</sup> [1]

- (b) The three rectangles all have the **same** area.

Work out the value of  $n$ .

(b)  $n =$  ..... [3]

11 (a) These are the first five terms in a Fibonacci sequence.

1 3 4 7 11

Write down the next two terms in the sequence.

(a) ..... [1]

(b) In a different Fibonacci sequence the fourth term is 31 and the fifth term is 50.

Work out the first term in this sequence.

(b) ..... [2]

(c) The second and third terms in the following Fibonacci sequence are  $x$  and  $y$ .

Write down algebraic expressions for the first, fourth and fifth terms.

.....  $x$   $y$  ..... [3]

- 12 A farmer has a field that is in the shape of a trapezium. He measures the field so that he can work out the area. He puts his measurements on this diagram of the field.

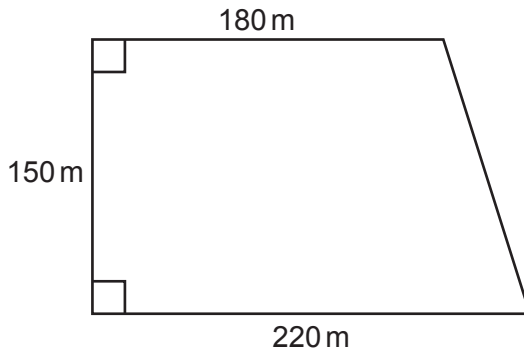

Not to scale

- (a) The farmer has rounded his measurements to two significant figures.

Give a reason why he may have done this.

.....  
 ..... [1]

- (b) The field produces 6400 kilograms of wheat per hectare. One hectare is 10 000 m<sup>2</sup>.

Work out how many kilograms of wheat the field produces.

(b) ..... kg [5]

13 The front and side elevations of a prism, with a pentagon as its cross section, are drawn on this one-centimetre square grid.

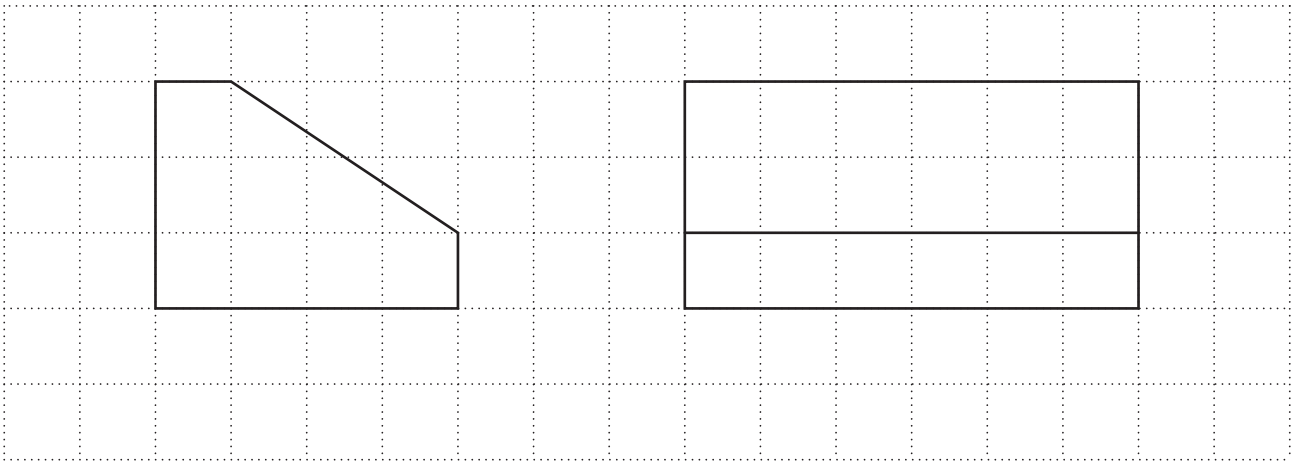

(a) Draw accurately the plan of the prism on the grid below.



[2]

(b) Calculate the volume of the prism.

(b) ..... cm<sup>3</sup> [3]

14 Work out  $\frac{2}{15} \times \frac{15}{22}$ .

Give your answer in its lowest terms.

..... [2]

15 The graph shows Mia's journey from her home to university.

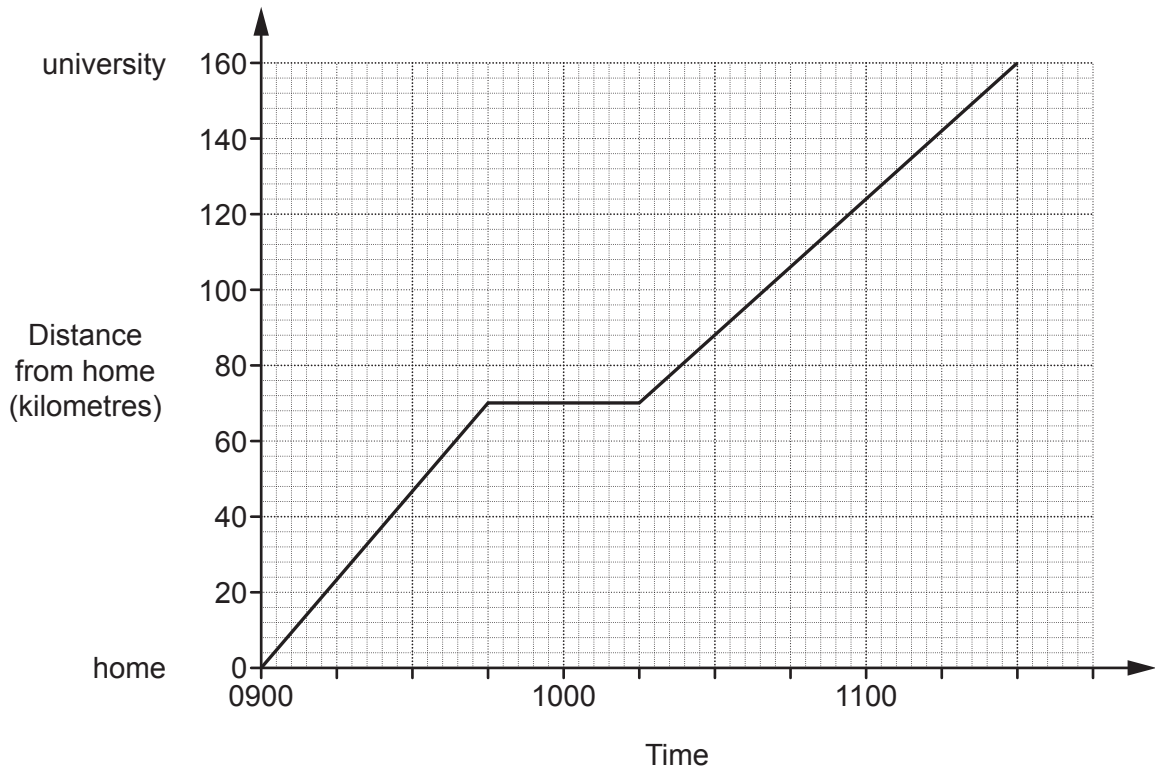

Calculate Mia's average speed for the whole journey.

..... km/h [3]

- 16 Last year, Katie earned £16 200.  
Her total loan repayments were £6400.

Katie estimates that the ratio of her loan repayments to her earnings is approximately 3 : 8.

Is she correct?  
Show your reasoning.

..... [3]



17 (a) Rearrange the equation to make  $x$  the subject.

$$y = 7x - 3$$

(a)  $x = \dots\dots\dots$  [2]

(b) Factorise.

(i)  $x^2 - xy$

(b)(i)  $\dots\dots\dots$  [1]

(ii)  $x^2 + 8x + 12$

(ii)  $\dots\dots\dots$  [2]

18 Jenny played four games of golf.  
For these games her modal score was 76 and her mean score was 75.  
Her range of scores was 10.

What were her scores for the four games?

$\dots\dots\dots$   $\dots\dots\dots$   $\dots\dots\dots$   $\dots\dots\dots$  [4]

19 The population of a village is in the following ratios.

- men : children = 11 : 3
- women : children = 5 : 2

(a) Find the ratio men : women.  
Give your answer in its simplest form.

(a) ..... : ..... [2]

(b) There are 36 children in the village.  
Find the total population of the village.

(b) ..... [3]

- 20 George is the manager of a shoe shop. He samples 50 of his customers and asks them about the **one** style of shoe they would buy next. The table shows his results.

Style of shoe	Number of customers
Laced shoes	18
Boots	15
Sandals	8
Trainers	5
Other	4

George buys 1000 pairs of shoes with the number of each style based on his survey results.

How many pairs of sandals should he buy?

Write down any assumption you make about his sample.

.....  
..... [3]

21 Triangles **P** and **Q** are right-angled.

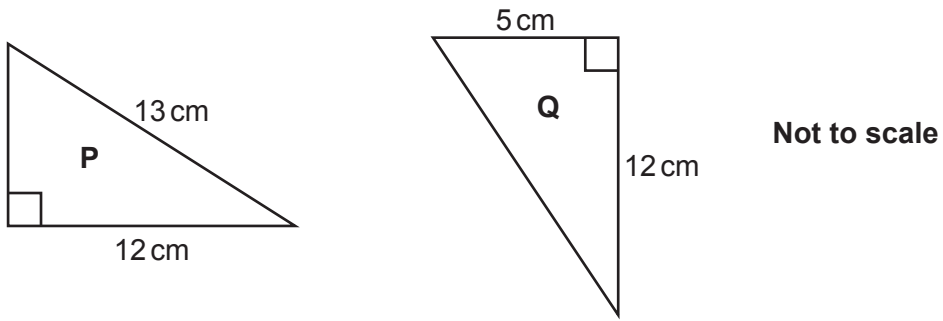

(a) Show that the two shorter sides in triangle **P** have the same lengths as the two shorter sides in triangle **Q**. [3]

(b) Explain why the two triangles are congruent.

.....  
..... [1]

**END OF QUESTION PAPER**

**Copyright Information**

OCR is committed to seeking permission to reproduce all third-party content that it uses in its assessment materials. OCR has attempted to identify and contact all copyright holders whose work is used in this paper. To avoid the issue of disclosure of answer-related information to candidates, all copyright acknowledgements are reproduced in the OCR Copyright Acknowledgements Booklet. This is produced for each series of examinations and is freely available to download from our public website ([www.ocr.org.uk](http://www.ocr.org.uk)) after the live examination series.

If OCR has unwittingly failed to correctly acknowledge or clear any third-party content in this assessment material, OCR will be happy to correct its mistake at the earliest possible opportunity.

For queries or further information please contact the Copyright Team, First Floor, 9 Hills Road, Cambridge CB2 1GE.

OCR is part of the Cambridge Assessment Group; Cambridge Assessment is the brand name of University of Cambridge Local Examinations Syndicate (UCLES), which is itself a department of the University of Cambridge.

## ERRATUM NOTICE

**Thursday 8 June 2017 – Morning**

**F**

**GCSE (9-1) Mathematics**

**J560/02** Paper 2 (Foundation Tier)

**FOR THE ATTENTION OF  
THE EXAMINATIONS OFFICER**

**To be opened on the day of the exam**

**Instructions to Invigilators:**

Before the start of the examination, please read out to candidates the following notice (please read out this notice **twice** to ensure understanding):

Please turn to **page 8, Question 7**, of the Question Paper.

Please add the following sentence on a new line after bullet point two:

This coin is put back.

Any enquiry about this notice should be referred to the Customer Contact Centre on 01223 553 998 or [general.qualifications@ocr.org.uk](mailto:general.qualifications@ocr.org.uk)