

Please write clearly in block capitals.

Centre number

--	--	--	--	--

Candidate number

--	--	--	--

Surname

Forename(s)

Candidate signature

GCSE MATHEMATICS (LINEAR)

H

Higher Tier Paper 2

Friday 4 November 2016

Morning

Time allowed: 2 hours

Materials

For this paper you must have:

- a calculator
- mathematical instruments.



Instructions

- Use black ink or black ball-point pen. Draw diagrams in pencil.
- Answer **all** questions.
- You must answer the questions in the spaces provided. Do not write outside the box around each page or on blank pages.
- Do all rough work in this book.

Information

- The marks for questions are shown in brackets.
- The maximum mark for this paper is 105.
- The quality of your written communication is specifically assessed in Questions 2, 6 and 20. These questions are indicated with an asterisk (*).
- You may ask for more answer paper, tracing paper and graph paper. These must be tagged securely to this answer book.

Advice

- In all calculations, show clearly how you work out your answer.



N 0 V 1 6 4 3 6 5 2 H 0 1

Formulae Sheet: Higher Tier

Area of trapezium = $\frac{1}{2}(a+b)h$

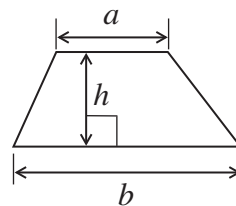

Volume of prism = area of cross section \times length

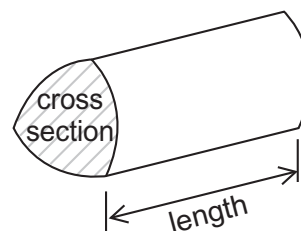

Volume of sphere = $\frac{4}{3}\pi r^3$

Surface area of sphere = $4\pi r^2$

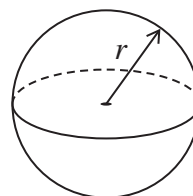

Volume of cone = $\frac{1}{3}\pi r^2 h$

Curved surface area of cone = $\pi r l$

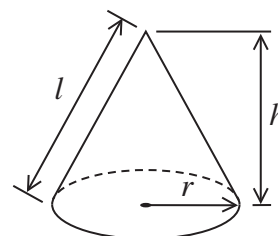

In any triangle ABC

Area of triangle = $\frac{1}{2}ab \sin C$

Sine rule $\frac{a}{\sin A} = \frac{b}{\sin B} = \frac{c}{\sin C}$

Cosine rule $a^2 = b^2 + c^2 - 2bc \cos A$

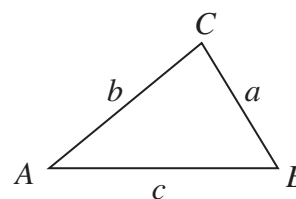

The Quadratic Equation

The solutions of $ax^2 + bx + c = 0$, where $a \neq 0$, are given by

$$x = \frac{-b \pm \sqrt{b^2 - 4ac}}{2a}$$



Answer **all** questions in the spaces provided.

- 1 On this grid, rotate shape *A* by 90° clockwise about point *P*.

[3 marks]

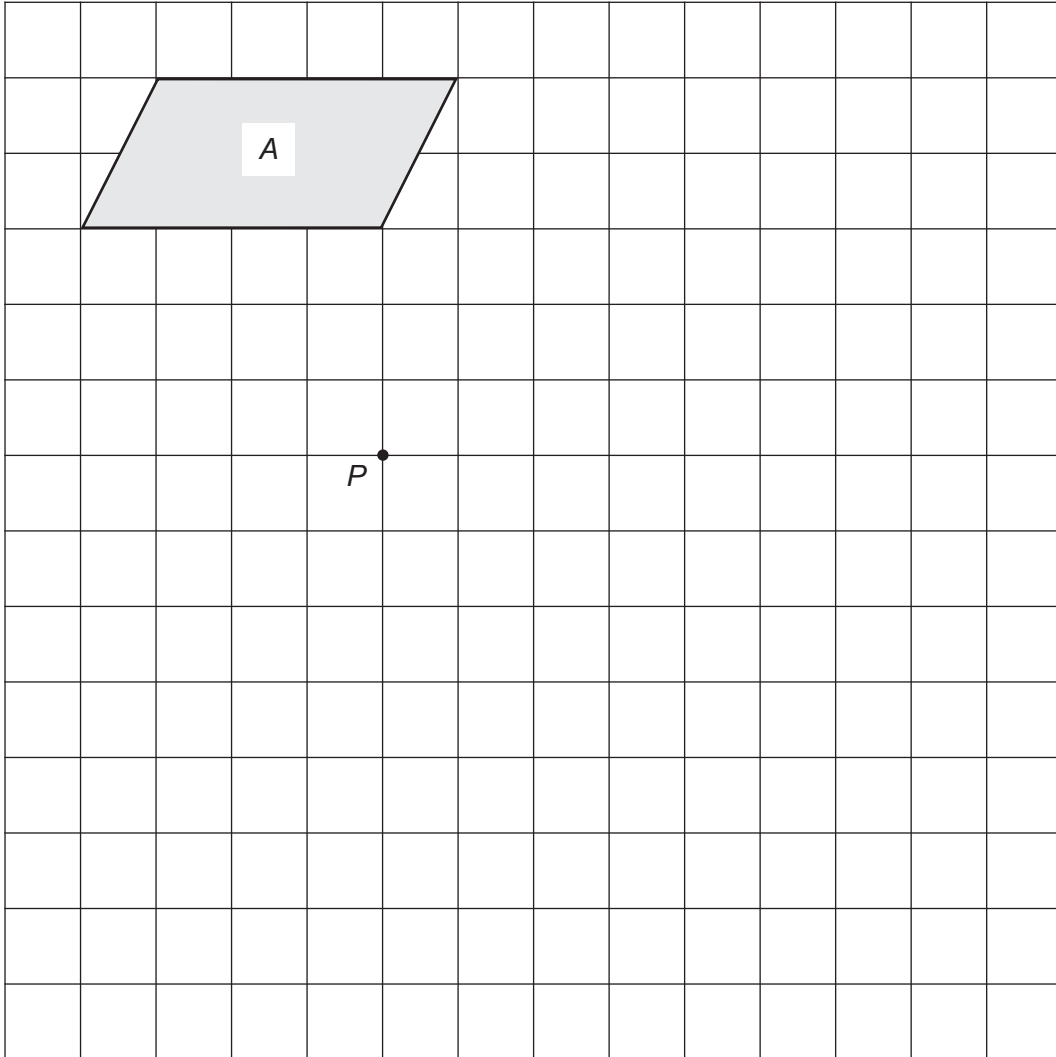

Turn over for the next question

Turn over ►



- 2 100 people are asked about their work.
Here are some of the results.

	Full time	Part time	Not working	Total
Men	24	9		60
Women	18			40
Total	42			100

- 2 (a) The total number working **part time** is the same as the total number of people **not working**.

Complete the table.

[4 marks]



***2 (b)** In this survey, there are 60 men and 40 women.

Which is greater

the percentage of the men who work full time

or

the percentage of the women who work full time?

You **must** show your working.

[3 marks]

Answer _____

Turn over for the next question



3 This hexagon has two lines of symmetry.

Not drawn accurately



Work out the size of angle y .

[3 marks]

Answer _____ degrees



4 A builder mixes sand and cement in the ratio 4 : 1

4 (a) Altogether he mixes 250 kg

How much sand and cement does he use?

[2 marks]

Sand _____ kg

Cement _____ kg

4 (b) Cement is sold in 25 kg bags.

Work out the **maximum** amount of mix that the builder can make with 3 bags of cement.

[3 marks]

Answer _____ kg

Turn over for the next question



5 (a) Complete the table of values for $y = x^2 - 5$ for values of x from -3 to 3

[2 marks]

x	-3	-2	-1	0	1	2	3
y	4		-4			-1	4

5 (b) Draw the graph of $y = x^2 - 5$ for values of x from -3 to 3

[2 marks]

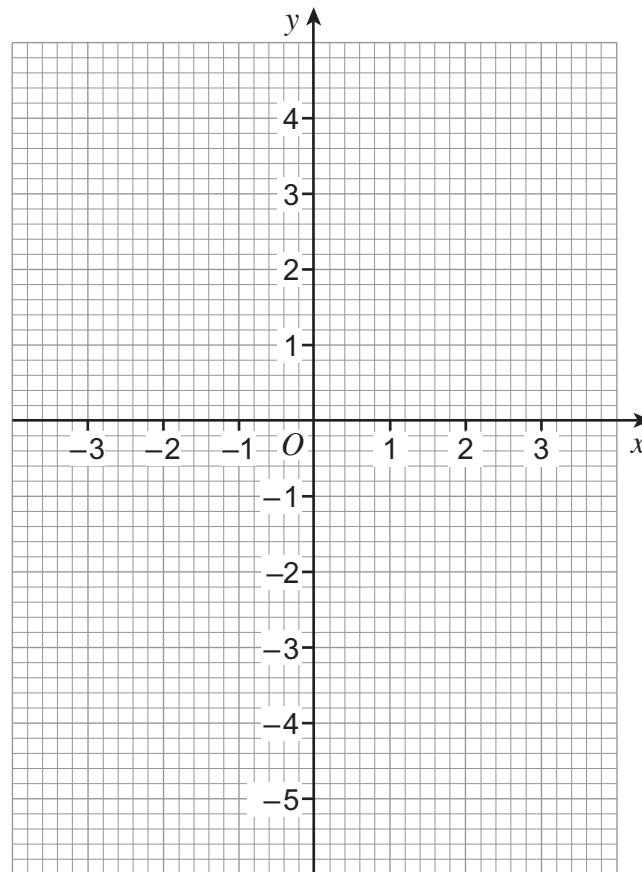

5 (c) Use the graph of $y = x^2 - 5$ to write down the values of x when $y = 0$

[1 mark]

Answer _____ and _____



- 6** The table shows the proportions of left-handed and right-handed students in a school.

	Left-handed	Right-handed
Boys	15%	85%
Girls	12%	88%

- *6 (a)** 20 boys and 10 girls are chosen at random from the school.

Estimate the number of left-handed students chosen.

[3 marks]

Answer _____

- 6 (b)** There are an equal number of boys and girls in the school.
A student is chosen at random.

Work out the probability that the student is right-handed.

[2 marks]

Answer _____



7 (a) Work out the area of a circle of radius 6 cm

[2 marks]

Answer _____ cm^2

7 (b) Quarter circles of radius 6 cm are cut from the corners of a rectangle as shown.

[3 marks]

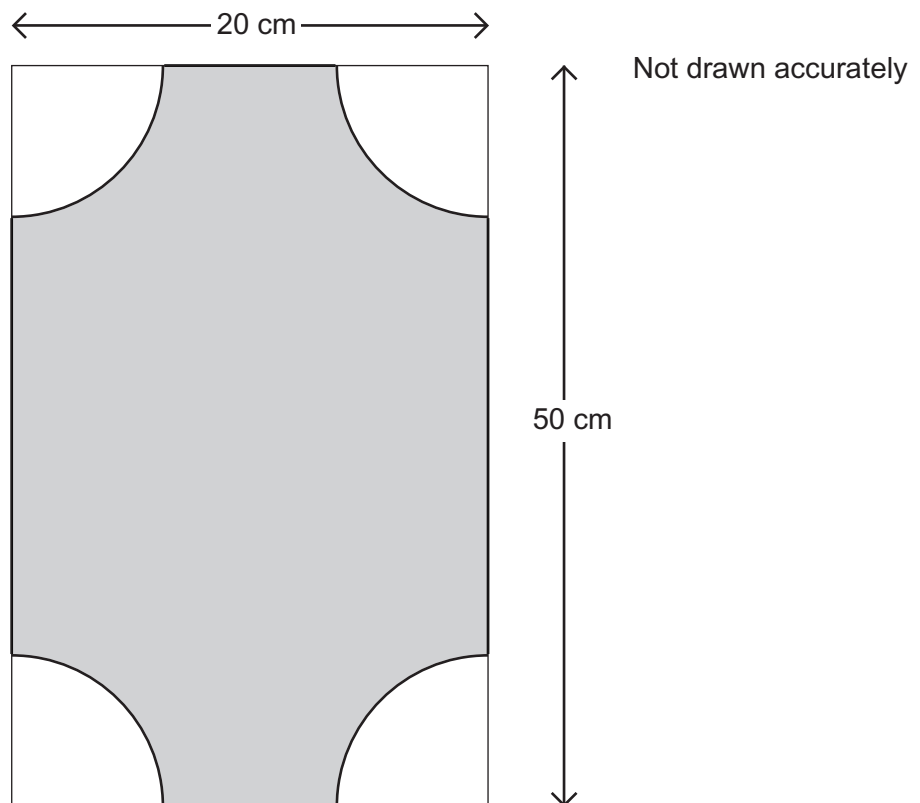

Work out the shaded area.

Answer _____ cm^2



- 8** In 1981 the population of England was 46 million.
In 2011 the population of England was 53 million.

Work out the increase in population as a percentage of the 1981 figure.

[3 marks]

Answer _____ %

Turn over for the next question



9

The area of the rectangle and the area of the triangle are equal.

Not drawn accurately

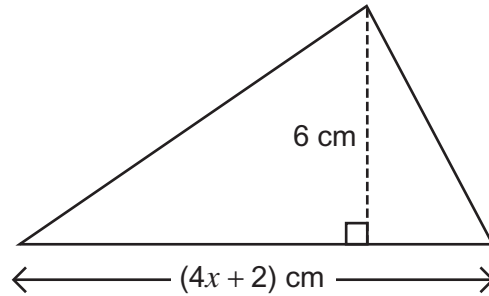
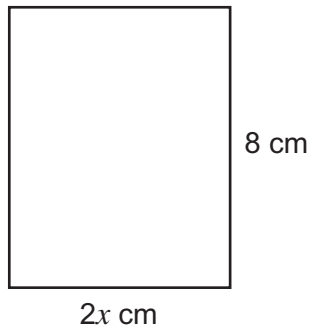

Work out the value of x .

[4 marks]

$x =$ _____



10

A ladder of length 31 feet is leaning against a wall as shown.
The foot of the ladder is 8 feet from the wall.
The wall is 35 feet tall.

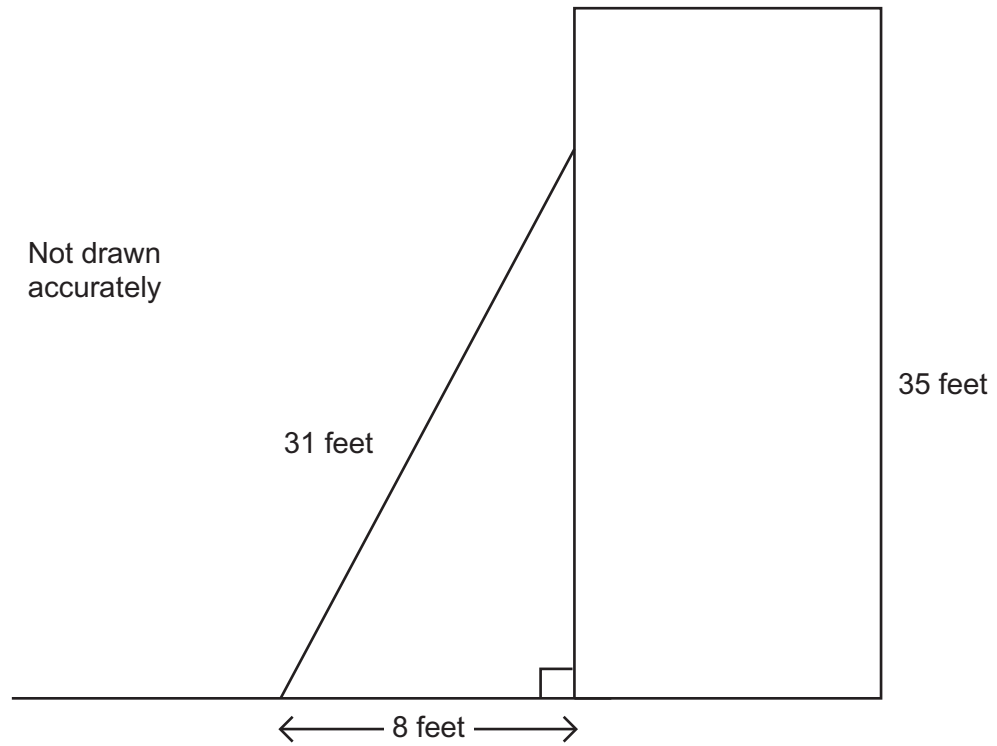

Work out the distance from the top of the ladder to the top of the wall.

[4 marks]

Answer _____ feet

8

Turn over ►



- 11** Bag A contains 3 red balls and 7 blue balls.
Bag B contains 8 red balls and 2 blue balls.



Bag A



Bag B

A ball is picked at random from each bag.

- 11 (a)** Complete the tree diagram to show all the probabilities.

[3 marks]

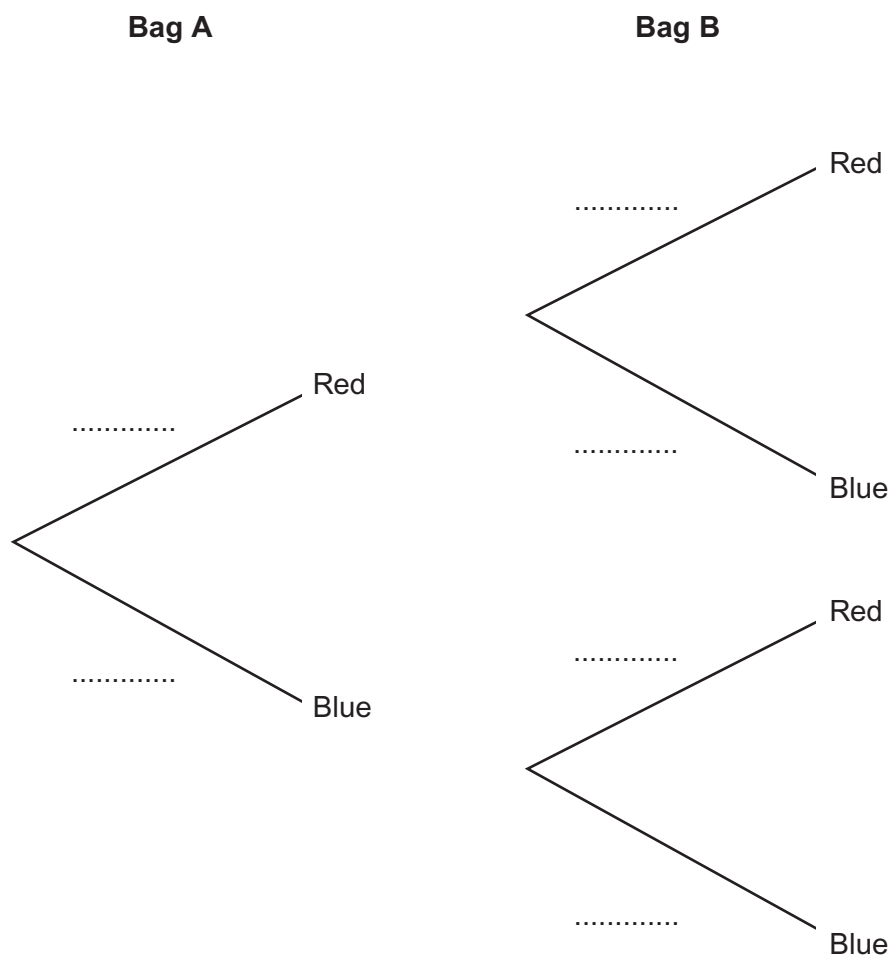

11 (b) Work out the probability of picking a **red** ball from Bag A and a **blue** ball from Bag B.

[2 marks]

Answer _____

Turn over for the next question



- 12 The straight line passes through points (0, 2) and (2, 8)

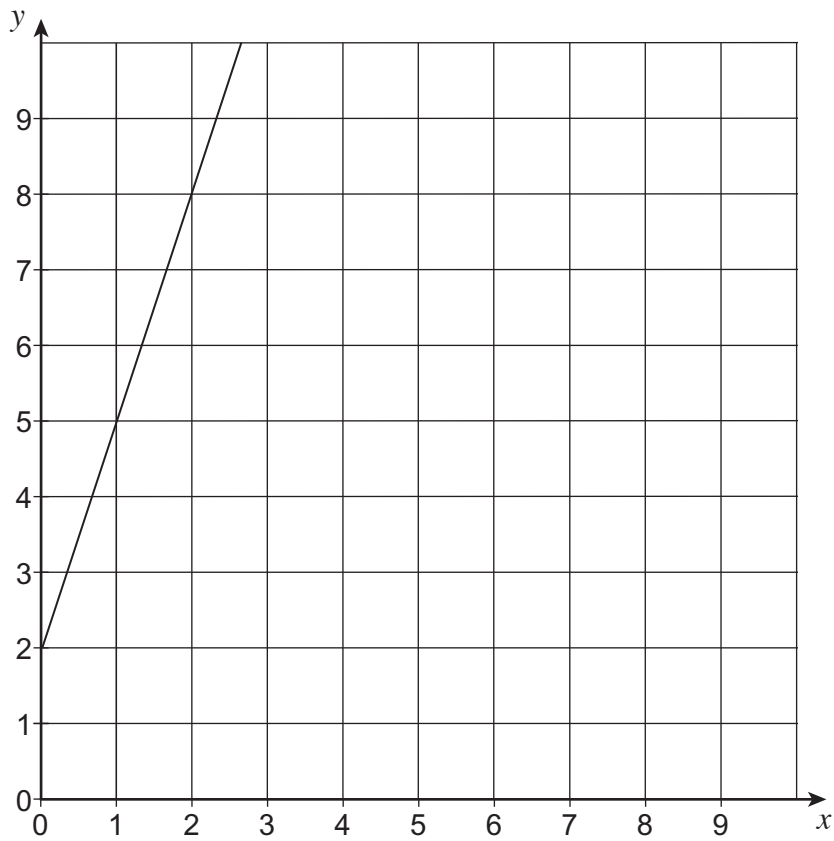

- 12 (a) Work out the equation of the straight line.

[3 marks]

Answer _____



12 (b) On this grid the line $y = \frac{1}{2}x$ is shown.

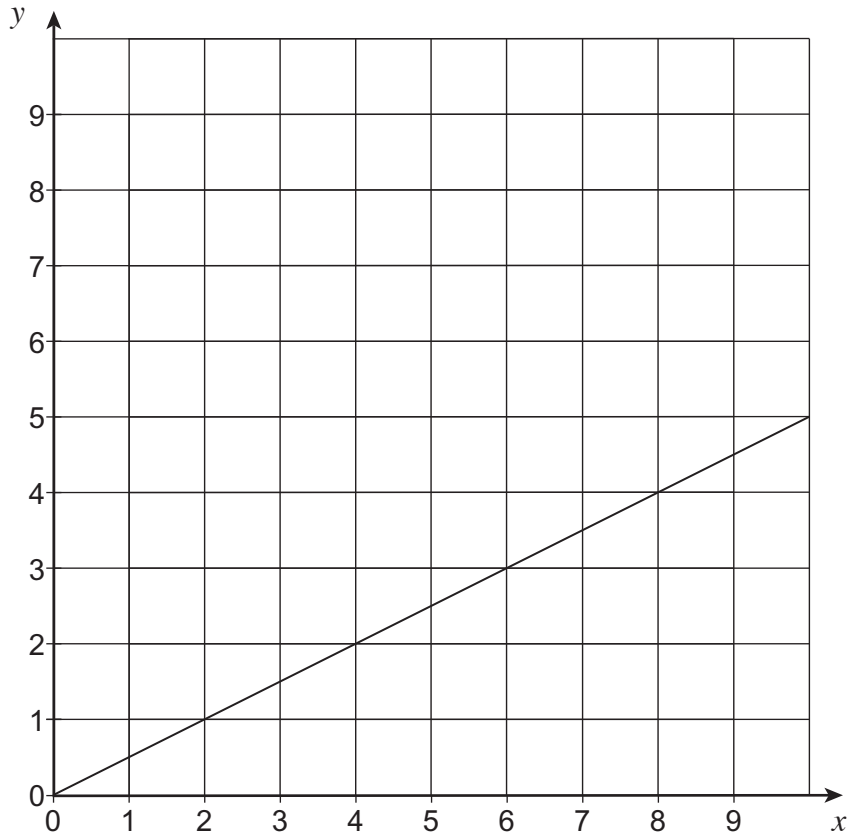

On the same grid, draw the line $x + y = 9$ for values of x from 0 to 9

[2 marks]

12 (c) Solve the simultaneous equations

$$y = \frac{1}{2}x$$

and $x + y = 9$

[2 marks]

Answer _____

7

Turn over ►



13 (a) Simplify fully $5x^2 \times 3y^4 \times 2x \times y^3$ **[2 marks]**

Answer _____

13 (b) Expand and simplify $(x + 7)(x - 3)$ **[2 marks]**

Answer _____

13 (c) Solve $(x - 8)(x + 2) = 0$ **[1 mark]**

Answer _____

13 (d) Factorise $8x^2y + 6xy^2$ **[2 mark]**

Answer _____



14 In a sale the normal price of a dress is reduced by 25%
The sale price is then reduced by £10

The dress is now priced at £80

The manager says,

“The price is now one-third less than the normal price.”

Show that he is correct.

[5 marks]

Turn over for the next question



- 15** A train company records the number of minutes, t , some trains were late in one month.

The histogram summarises the results.

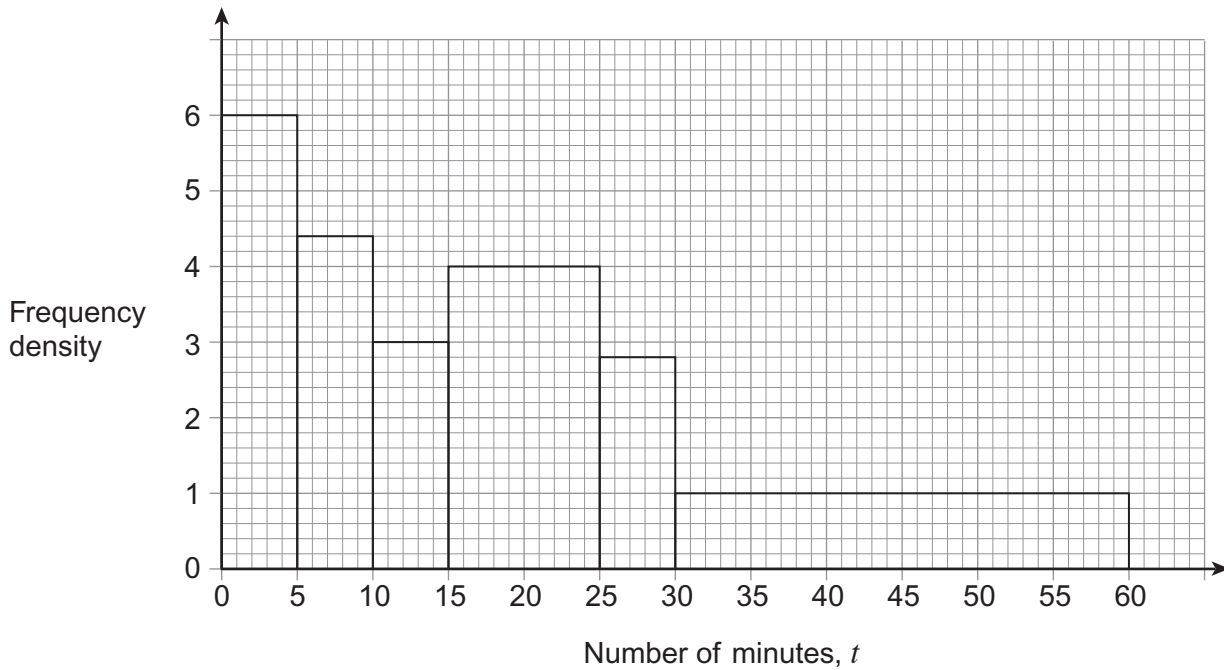

- 15 (a)** How many trains were **more** than 15 minutes late?

[3 marks]

Answer _____



15 (b) Which is the modal class?

Circle your answer.

[1 mark]

$0 < t \leq 5$

$15 < t \leq 25$

$25 < t \leq 30$

$30 < t \leq 60$

16 Which of these when converted to decimals are recurring decimals?
Circle your answers.

[2 marks]

$\frac{1}{3}$

 π

$\sqrt{3}$

$\frac{3}{16}$

$\frac{5}{7}$

Turn over for the next question



17 The surface area of a solid cylinder is given by the formula

$$S = 2\pi rh + 2\pi r^2$$

17 (a) Rearrange the formula to make h the subject.

[2 marks]

Answer _____

17 (b) Work out the value of h when $S = 95\pi \text{ cm}^2$ and $r = 5.3 \text{ cm}$
Give your answer to a suitable degree of accuracy.

[4 marks]

Answer _____ cm



18 y is inversely proportional to x^2 where $x > 0$

When $x = 2$, $y = 20$

18 (a) Form an equation for y in terms of x .

[3 marks]

Answer _____

18 (b) Work out the value of x when $y = 5$

[2 marks]

Answer _____



19 (a) Work out the length x .

[3 marks]

Not drawn accurately

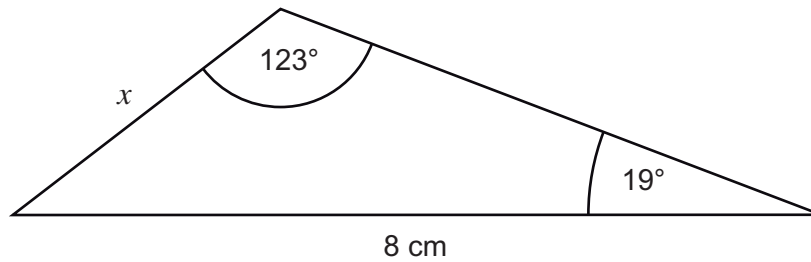

Answer _____ cm

19 (b) Circle the statements that are true.

[2 marks]

$$\sin 123^\circ = \sin 57^\circ$$

$$\sin 123^\circ = \cos 57^\circ$$

$$\cos 123^\circ = \cos 57^\circ$$

$$\cos 123^\circ = -\cos 57^\circ$$



19 (c) Work out the length y .

[1 mark]

Not drawn accurately

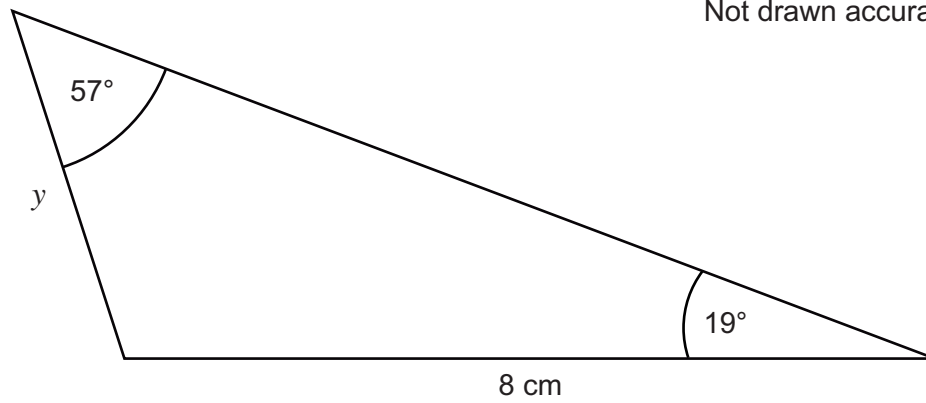

Answer _____ cm

Turn over for the next question



***20**

A rectangle of card, 20 cm by 10 cm, is used to make a cylindrical tube A, as shown.
The card does **not** overlap.

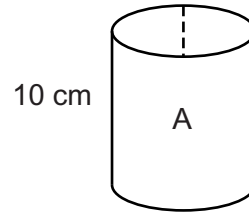
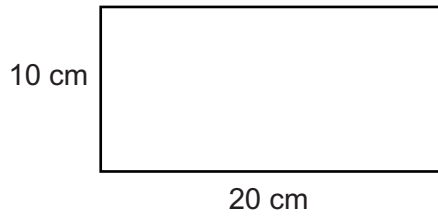

Not drawn
accurately

Another rectangle of card, 20 cm by 10 cm, is used to make a cylindrical tube B, as shown.
The card does **not** overlap.

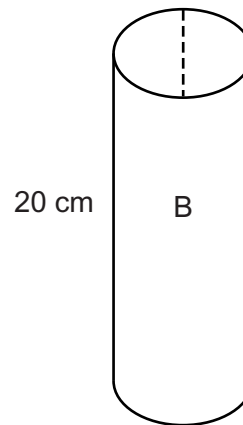
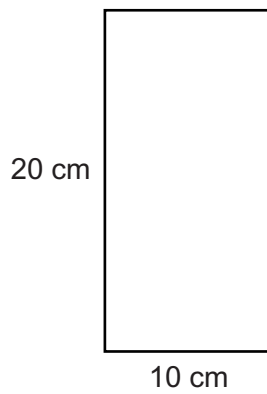

Not drawn
accurately



The tubes are filled with clay.

Which tube uses more clay?
You **must** show your working.

[4 marks]

Answer _____

Turn over for the next question

4

Turn over ►



21 Use algebra to work out the x -coordinates of the points of intersection of

$$y = 3x^2$$

and $y = 4x + 2$

Give your answers to 1 decimal place.

[5 marks]

Answer _____



22

Work out the height h of the triangle ABC .

Not drawn accurately

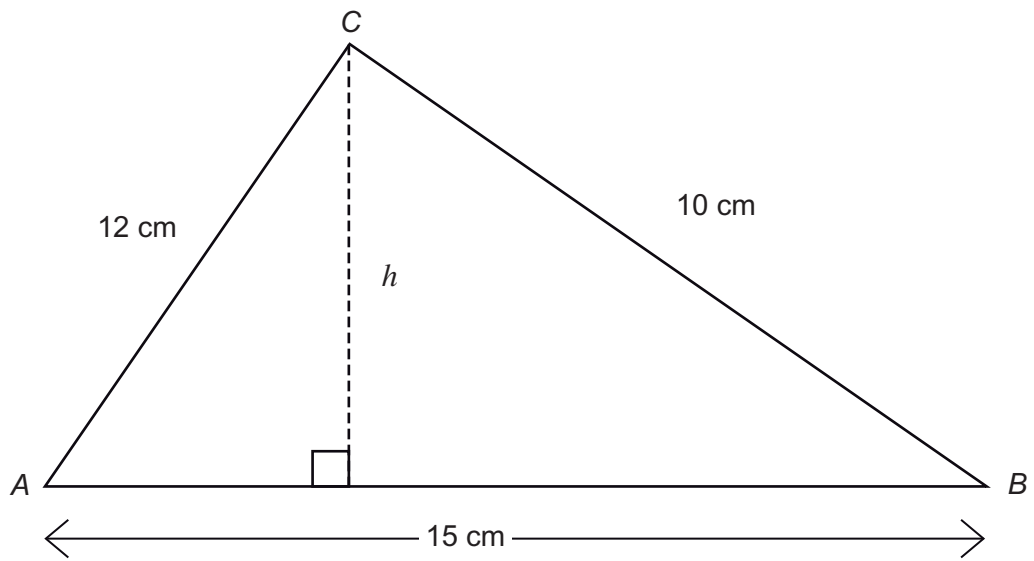
**[5 marks]**

Answer _____ cm

END OF QUESTIONS

There are no questions printed on this page

**DO NOT WRITE ON THIS PAGE
ANSWER IN THE SPACES PROVIDED**



There are no questions printed on this page

**DO NOT WRITE ON THIS PAGE
ANSWER IN THE SPACES PROVIDED**



There are no questions printed on this page

**DO NOT WRITE ON THIS PAGE
ANSWER IN THE SPACES PROVIDED**

Copyright Information

For confidentiality purposes, from the November 2015 examination series, acknowledgements of third party copyright material will be published in a separate booklet rather than including them on the examination paper or support materials. This booklet is published after each examination series and is available for free download from www.aqa.org.uk after the live examination series.

Permission to reproduce all copyright material has been applied for. In some cases, efforts to contact copyright-holders may have been unsuccessful and AQA will be happy to rectify any omissions of acknowledgements. If you have any queries please contact the Copyright Team, AQA, Stag Hill House, Guildford, GU2 7XJ.

Copyright © 2016 AQA and its licensors. All rights reserved.

