

Thursday 13 June 2013 – Morning

**GCSE TWENTY FIRST CENTURY SCIENCE
PHYSICS A**

A182/01 Modules P4 P5 P6 (Foundation Tier)

Candidates answer on the Question Paper.
A calculator may be used for this paper.

OCR supplied materials:
None

Other materials required:

- Pencil
- Ruler (cm/mm)

Duration: 1 hour



Candidate forename		Candidate surname	
-----------------------	--	----------------------	--

Centre number						Candidate number				
---------------	--	--	--	--	--	------------------	--	--	--	--

INSTRUCTIONS TO CANDIDATES

- Write your name, centre number and candidate number in the boxes above. Please write clearly and in capital letters.
- Use black ink. HB pencil may be used for graphs and diagrams only.
- Answer **all** the questions.
- Read each question carefully. Make sure you know what you have to do before starting your answer.
- Write your answer to each question in the space provided. Additional paper may be used if necessary but you must clearly show your candidate number, centre number and question number(s).
- Do **not** write in the bar codes.

INFORMATION FOR CANDIDATES

- Your quality of written communication is assessed in questions marked with a pencil (✎).
- A list of useful relationships is printed on page 2.
- The number of marks is given in brackets [] at the end of each question or part question.
- The total number of marks for this paper is **60**.
- This document consists of **20** pages. Any blank pages are indicated.

TWENTY FIRST CENTURY SCIENCE EQUATIONS

Useful relationships

The Earth in the Universe

$$\text{distance} = \text{wave speed} \times \text{time}$$

$$\text{wave speed} = \text{frequency} \times \text{wavelength}$$

Sustainable energy

$$\text{energy transferred} = \text{power} \times \text{time}$$

$$\text{power} = \text{voltage} \times \text{current}$$

$$\text{efficiency} = \frac{\text{energy usefully transferred}}{\text{total energy supplied}} \times 100\%$$

Explaining motion

$$\text{speed} = \frac{\text{distance travelled}}{\text{time taken}}$$

$$\text{acceleration} = \frac{\text{change in velocity}}{\text{time taken}}$$

$$\text{momentum} = \text{mass} \times \text{velocity}$$

$$\text{change of momentum} = \text{resultant force} \times \text{time for which it acts}$$

$$\text{work done by a force} = \text{force} \times \text{distance moved in the direction of the force}$$

$$\text{amount of energy transferred} = \text{work done}$$

$$\text{change in gravitational potential energy} = \text{weight} \times \text{vertical height difference}$$

$$\text{kinetic energy} = \frac{1}{2} \times \text{mass} \times [\text{velocity}]^2$$

Electric circuits

$$\text{power} = \text{voltage} \times \text{current}$$

$$\text{resistance} = \frac{\text{voltage}}{\text{current}}$$

$$\frac{\text{voltage across primary coil}}{\text{voltage across secondary coil}} = \frac{\text{number of turns in primary coil}}{\text{number of turns in secondary coil}}$$

Radioactive materials

$$\text{energy} = \text{mass} \times [\text{speed of light in a vacuum}]^2$$

Answer **all** the questions.

1 Read the following article.

Some cancers are treated with a form of radiation therapy called brachytherapy. A small piece of material that is radioactive is placed inside a tumour. The radioactive material then decays, releasing ionising radiation that destroys the tumour.

(a) (i) Write down words or phrases **from the article** that mean the following:

breaks down over time

produces ionising radiation

[2]

(ii) The three types of ionising radiation from radioactive materials travel different distances.

Write **alpha**, **beta** and **gamma** in the boxes to show how far each type of ionising radiation travels through the body.

travels the shortest distance	—————→	travels the greatest distance
.....

[1]

(b) (i) Which two statements explain why the ionising radiation “destroys the tumour”?

Put ticks (✓) in the boxes next to the **two** best answers.

Ionising radiation...

... can break molecules into bits.

... gets stronger over time.

... is produced from the electrons in atoms.

... can be destroyed using acid.

... kills living cells.

[2]

(ii) Which statement explains why the radioactive material decays at the same rate both inside and outside the body?

Put a tick (✓) in the box next to the correct answer.

The movement of the body speeds up the decay.

The heat from the body increases the radioactivity.

The decay is not affected by chemicals in the body.

The body shields the radioactive material from light.

[1]

(c) Which of the following is **not** another use for ionising radiation?

Put a tick (✓) in the box next to the correct answer.

to sterilise food

as a tracer in the body

to sterilise surgical instruments

to send messages from mobile phones

[1]

(d) For brachytherapy to be effective:

- the radioactive material must remain in the tumour long enough for the tumour to be destroyed
- the activity must be low after that time.

One particular tumour will have to be treated for 6 months to be destroyed.

A doctor has a choice of three different substances to treat the tumour.

Each substance gives out the same type of radiation.

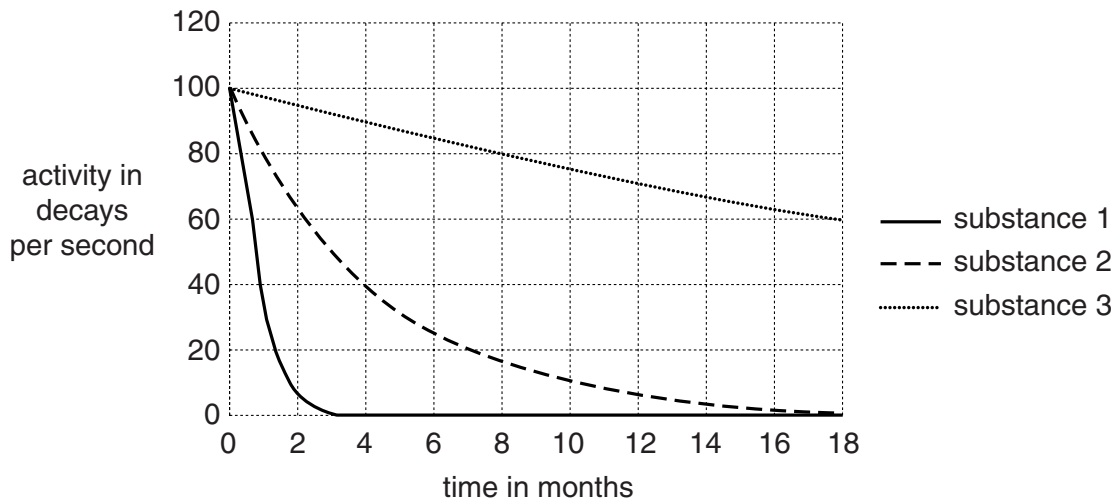

Which substance should the doctor use to treat this tumour?

Justify your answer.

substance

.....

.....

.....

.....

[3]

(e) (i) Denis wants to know if he should have brachytherapy for a cancer in his prostate gland.

He finds the following information:

- the therapy is successful in most cases
- 2 out of 125 patients in a study who had brachytherapy for prostate cancer went on to develop a cancer in a nearby organ as well.

Denis decides to go ahead with the therapy.

Suggest why he came to this conclusion, using this information.

.....

.....

.....

..... [3]

(ii) When doing his research, Denis finds information about the dose (in sieverts) from different treatments.

Which of the following statements explains what 'dose (in sieverts)' means?

Put a tick (✓) in the box next to the correct answer.

a measure of the possible harm to the body from radiation

how many cells are ionised by a source

the number of particles in a radioactive sample

[1]

[Total: 14]

BLANK PAGE

Question 3 begins on page 8

PLEASE DO NOT WRITE ON THIS PAGE

3 Anita is investigating three different electrical components, **A**, **B** and **C**.

(a) She changes the temperature of each component and measures the resistance.

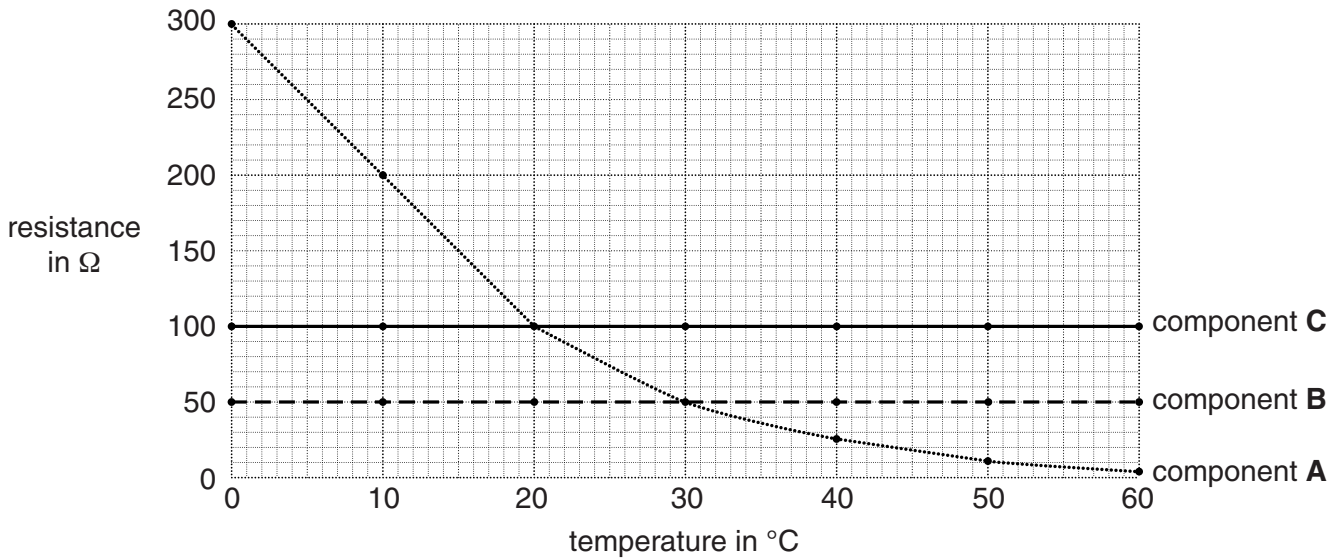

She then changes the amount of light on each component and measures the resistance.

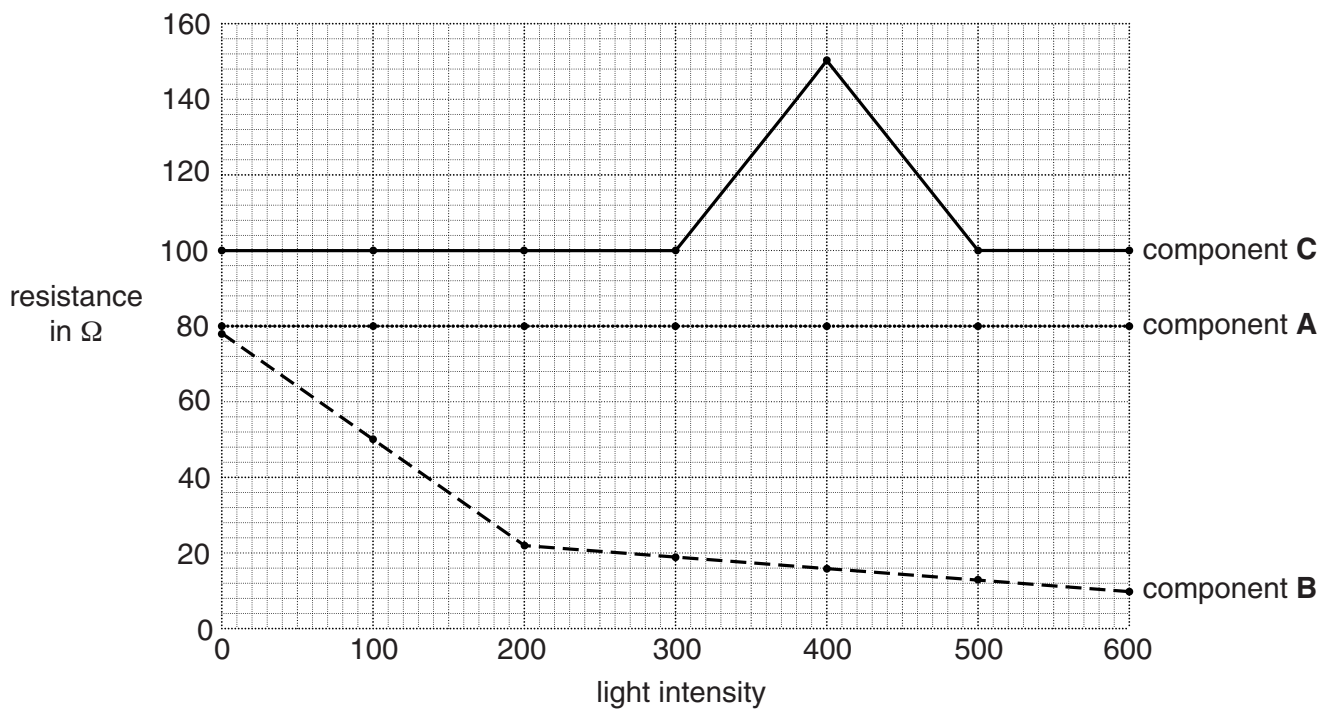

(i) Use the data to decide what each component is.

Draw straight lines to link each **component** to its **type**, and each **type** to its **symbol**.

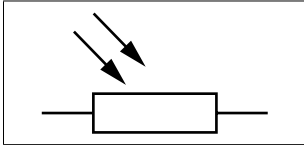
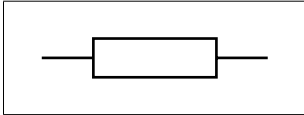
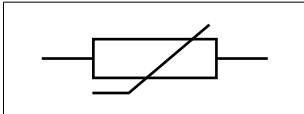
component	type	symbol
A	fixed resistor	
B	LDR	
C	thermistor	

[4]

(ii) Use the data to decide whether each statement about Anita's experiment is **true**, **false** or you **cannot tell**.

Put ticks (✓) in the correct boxes.

	true	false	cannot tell
Anita repeated her experiment three times.			
Anita had an outlier in her results.			

[2]

(b) (i) Anita measured the voltage and current of component **A**.

She used a 6V power supply. The current through the component was 0.06 A.

Calculate the resistance of the component.

Show your working.

resistance = Ω [2]

(ii) Later, Anita used component **A** to find an unknown temperature.

The resistance of component **A** was 200Ω .

Use the first graph to find the unknown temperature.

temperature = $^{\circ}\text{C}$ [1]

[Total: 9]

Turn over

4 The diagram shows the main features of a motor.

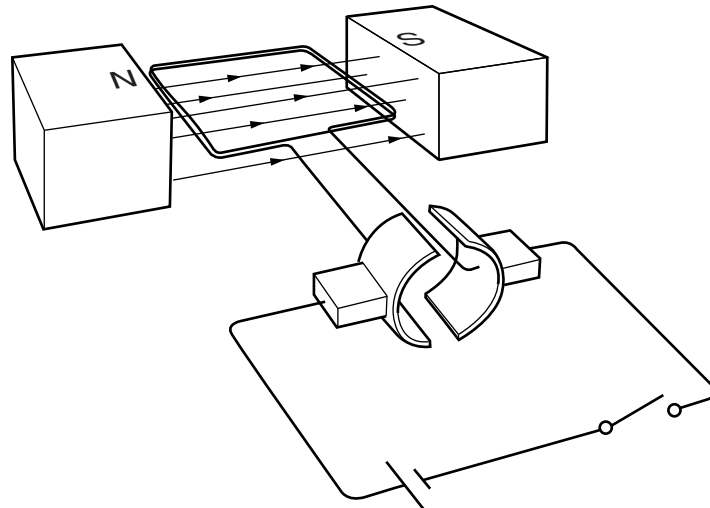

Add labels to the diagram and use it to explain how a motor works.



The quality of written communication will be assessed in your answer.

..... [6]

[Total: 6]

5 (a) Alice has a new toy.

It uses an electrostatic effect to make it 'fly'.

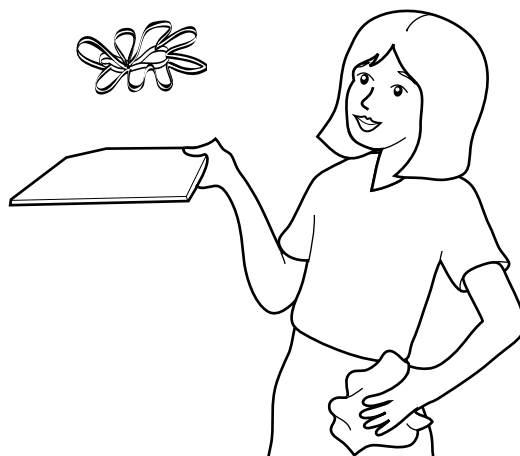

The toy has three parts: a plastic tray, a plastic 'flyer' and a cloth.

- She rubs the flyer with the cloth.
- She rubs the tray with the cloth.
- The flyer hovers above the tray.

Explain why rubbing the tray and the flyer makes the flyer hover above the tray.

.....

.....

.....

..... [3]

(b) Static electricity is different from current electricity.

Complete the table to show whether each statement applies to **static electricity**, **current electricity** or **both**.

Put a tick (✓) in the one correct box in each row.

	Static electricity	Current electricity	Both
involves electrons			
involves a flow of charge			
requires a power supply or battery			
involves charged insulators			

[3]

[Total: 6]

6 Ross is doing an experiment with shoes.

He places a shoe at the top of a ramp and measures the time it takes the shoe to slide down the ramp.

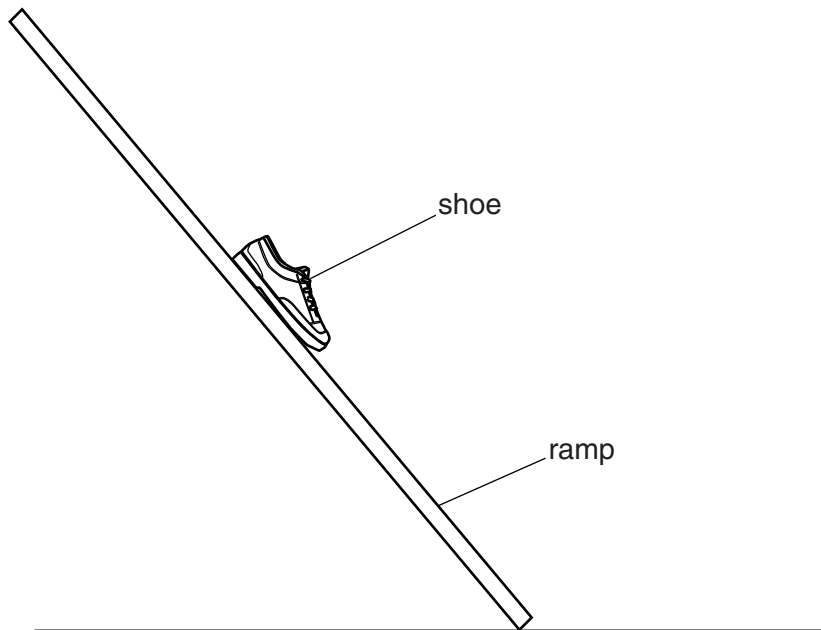

Ross has four different size shoes.

He does the experiment three times with each shoe.

Here are his results.

Shoe size	Time to slide down the ramp in seconds		
	Test 1	Test 2	Test 3
5	0.9	1.0	1.0
7	1.3	1.2	1.1
9	1.4	1.5	1.4
11	1.6	1.6	1.7

(a) Ross measured the distance the shoes slide down the ramp to be 1.8 m.

Calculate the average speed of the **size 7** shoe down the ramp, and write down the unit.

Show your working.

speed = unit [3]

(b) (i) Read the statements about his data.

Put ticks (✓) in the boxes to show whether each statement is **true** or **false**.

	True	False
As the shoe size increases, the time taken to slide down the ramp increases.		
As some of the repeats are different, Ross must have made mistakes in his experiment.		

[1]

(ii) Another student tries to make the same measurements with another ramp and a shoe of size 4.

Here are the results.

Shoe size	Time to slide down the ramp in seconds		
	Test 1	Test 2	Test 3
4	1.2	1.4	1.3

Ross says: "You must have made a mistake. Your results do not fit my data."

Is Ross correct?

Justify your answer.

.....

.....

.....

.....

..... [3]

(c) The forces on a shoe as it rests on a ramp are shown in the diagram.

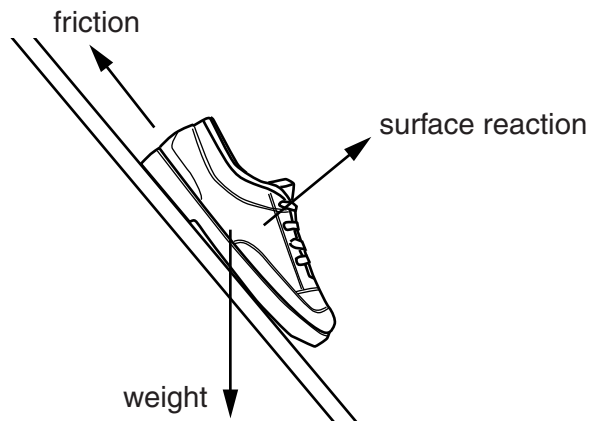

Complete the sentences about this situation.

Choose words from the list.

- | | | | |
|-----------------|--------------|-----------------|---------------|
| balanced | Earth | large | mass |
| ramp | small | vertical | weight |

Each force comes from an interaction between two objects.

The friction on the shoe is caused by the interaction between the shoe and the

The weight of the shoe is caused by the interaction between the shoe and the

If the shoe is stationary, then the forces must be

[3]

(d) Ali carried out a similar experiment to Ross.

She used three shoes which were all size 7. Each shoe had a different tread pattern.

She repeated her experiment three times.

(i) Draw a line from each **feature of her experiment** to the correct **reason** for the feature.

Draw **two** lines only.

feature of her experiment

reason

all shoes were size 7

repeat the experiment
three times

to control this factor

to get a better estimate of
the true value

to increase the range of
the experiment

to improve the precision of
the experiment

[1]

(ii) Ali drew distance-time graphs of her results.

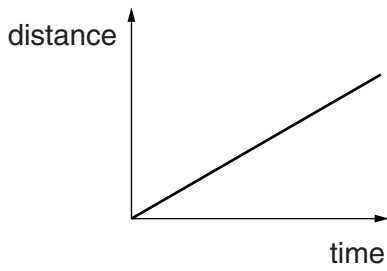

tread pattern A

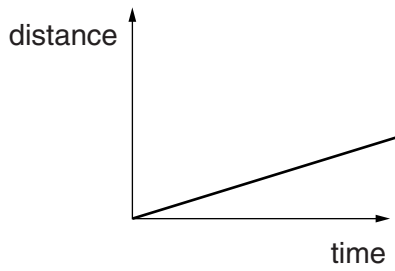

tread pattern B

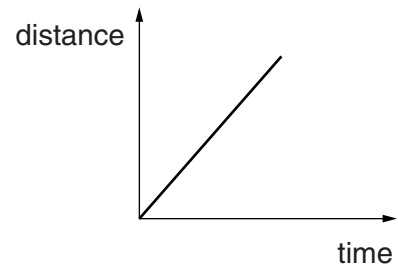

tread pattern C

Which tread pattern allowed the shoe to move fastest down the slope?

All graphs are drawn to the same scale.

tread [1]

(iii) Ali then drew a **speed**-time graph of her results.

She forgot to label the three lines.

Write **A**, **B** and **C** next to each of the lines to show which line is for which tread pattern.



[1]

[Total: 13]

7 A simple roller coaster has one line of track on which a vehicle travels backwards and forwards.

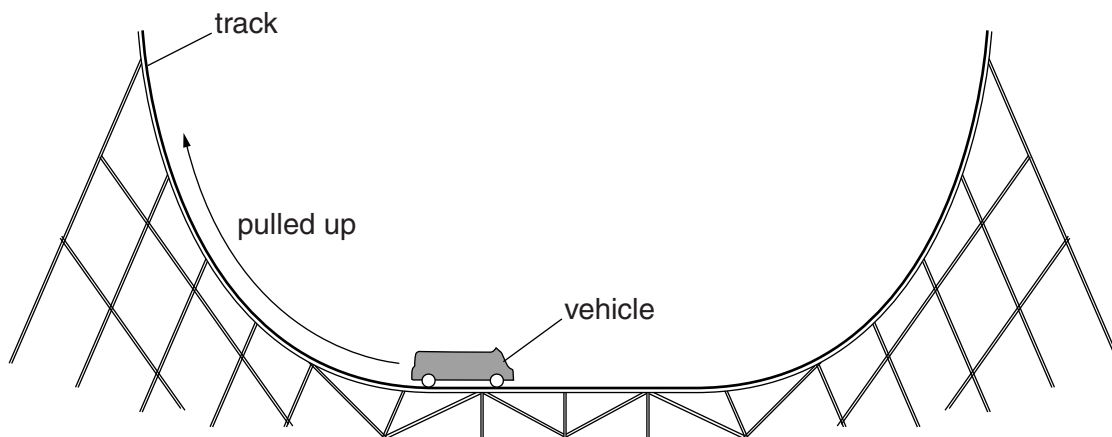

- The vehicle is pulled up the left side of the track, and is then released.
- It travels down the track, speeding up as it moves.
- It rises up the right side of the track, slowing down as it moves upwards.
- It rolls back down.
- It moves backwards and forwards on the track several times, with each move becoming lower and lower and the top speed becoming slower and slower.

Use ideas of energy to explain the motion of the vehicle.



The quality of written communication will be assessed in your answer.

.....

.....

.....

.....

.....

.....

.....

.....

.....

.....

.....

..... [6]

[Total: 6]

END OF QUESTION PAPER

18
BLANK PAGE

PLEASE DO NOT WRITE ON THIS PAGE

BLANK PAGE

PLEASE DO NOT WRITE ON THIS PAGE

PLEASE DO NOT WRITE ON THIS PAGE



Copyright Information

OCR is committed to seeking permission to reproduce all third-party content that it uses in its assessment materials. OCR has attempted to identify and contact all copyright holders whose work is used in this paper. To avoid the issue of disclosure of answer-related information to candidates, all copyright acknowledgements are reproduced in the OCR Copyright Acknowledgements Booklet. This is produced for each series of examinations and is freely available to download from our public website (www.ocr.org.uk) after the live examination series.

If OCR has unwittingly failed to correctly acknowledge or clear any third-party content in this assessment material, OCR will be happy to correct its mistake at the earliest possible opportunity.

For queries or further information please contact the Copyright Team, First Floor, 9 Hills Road, Cambridge CB2 1GE.

OCR is part of the Cambridge Assessment Group; Cambridge Assessment is the brand name of University of Cambridge Local Examinations Syndicate (UCLES), which is itself a department of the University of Cambridge.