

## Friday 14 June 2019 – Morning

### GCSE (9–1) Physics B (Twenty First Century Science)

#### J259/04 Depth in physics (Higher Tier)

Time allowed: 1 hour 45 minutes



**You must have:**

- the Data Sheet (for GCSE Physics B (inserted))
- a ruler (cm/mm)

**You may use:**

- a scientific or graphical calculator
- an HB pencil



Please write clearly in black ink. **Do not write in the barcodes.**

Centre number

--	--	--	--	--

Candidate number

--	--	--	--

First name(s)

---

Last name

---

### INSTRUCTIONS

- The Data Sheet will be found inside this document.
- Use black ink. You may use an HB pencil for graphs and diagrams.
- Answer **all** the questions.
- Where appropriate, your answers should be supported with working. Marks may be given for a correct method even if the answer is incorrect.
- Write your answer to each question in the space provided. If additional space is required, use the lined page(s) at the end of this booklet. The question number(s) must be clearly shown.

### INFORMATION

- The total mark for this paper is **90**.
- The marks for each question are shown in brackets [ ].
- Quality of extended responses will be assessed in questions marked with an asterisk (\*).
- This document consists of **24** pages.

Answer **all** the questions.

1 This question is about gears and levers.

(a) A wristwatch with its back cover removed is shown in **Fig. 1.1**.

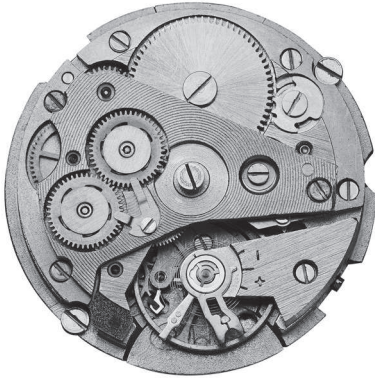

**Fig. 1.1**

You can see some of the gears inside the wristwatch.

Two gears **Q** and **R** are shown in **Fig. 1.2**.

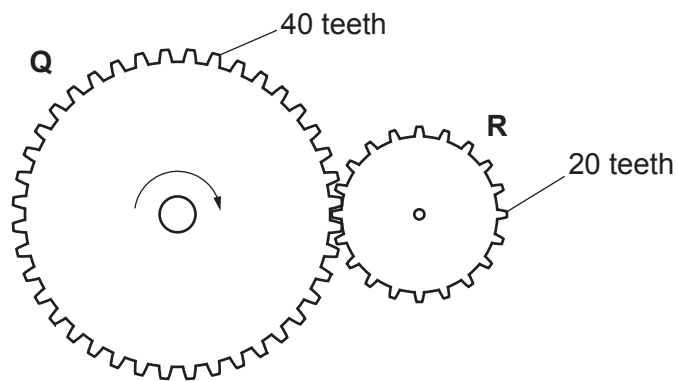

**Fig. 1.2**

The gear **Q** has 40 teeth and gear **R** has 20 teeth. Both gears have the same size teeth.

The gear **Q** moves in a clockwise direction.

Gear **Q** rotates at 6 revolutions per minute.

(i) On **Fig. 1.2**, show the direction of rotation of gear **R**. [1]

(ii) How many revolutions are completed by gear **R** in one minute?

Number of revolutions = ..... per minute [2]

(b) The lid of a can of paint has a lip which makes it easier to open, using a lever.

The diagram below shows a screwdriver placed under the lip.

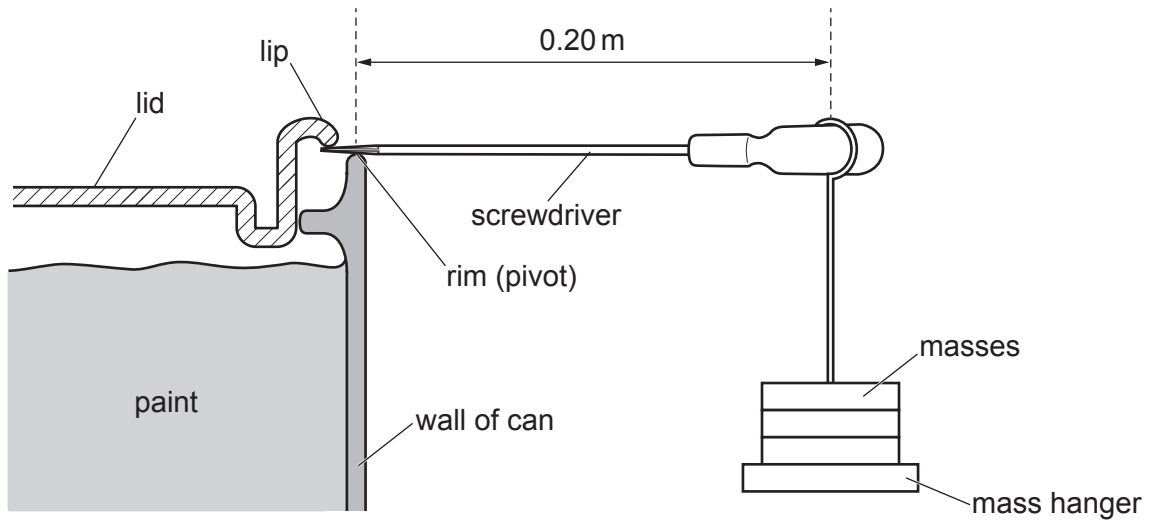

**Fig. 1.3**

In an experiment, masses are added to the mass hanger to open the lid.

The mass hanger hangs at a distance of 0.20 m from the rim (pivot) of the can.

A total weight of 32 N of the hanging masses opens the lid.

Calculate the moment of this force.

Moment = ..... Nm [3]

- 2\* Kai is doing experiments in the laboratory to determine the density of the two different liquids, **E** and **F**.

He uses a measuring cylinder placed on a balance.

He then pours different volumes of liquid **E** into the measuring cylinder, and records the balance reading, as shown in **Fig. 2.1**. The balance reading is equal to the total mass of the measuring cylinder and the liquid.

He then empties the measuring cylinder, and repeats the same procedure with liquid **F**.

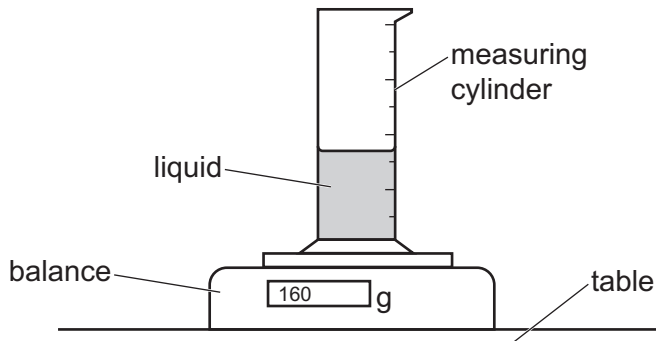

**Fig. 2.1**

Kai's results are shown in **Fig. 2.2**.

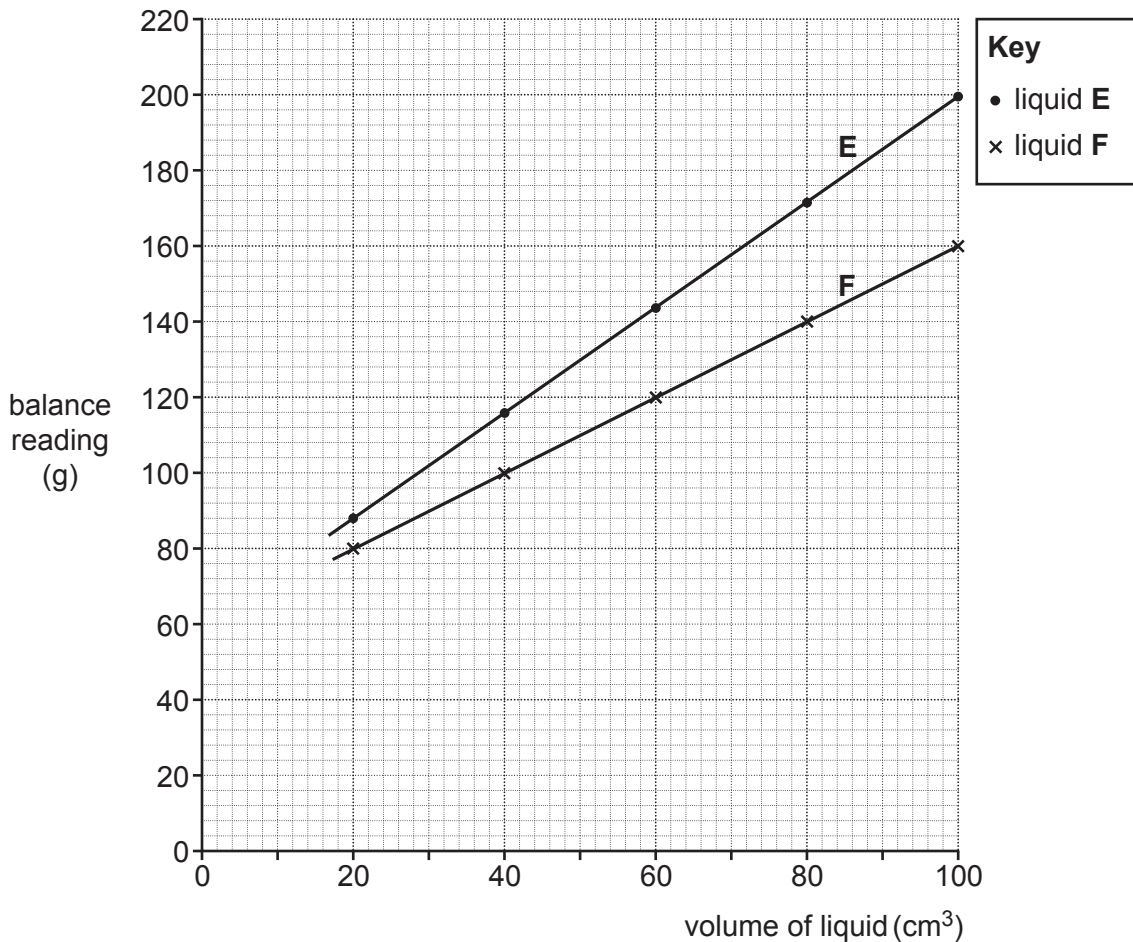

**Fig. 2.2**



- 3 Lyla and Alex are investigating two identical light-dependent resistors (LDRs). A torch is used as a light source by Lyla, and Alex decides to use a table lamp.

Each light source is placed above the LDR.

The resistance of the LDR is determined for different numbers of identical sheets of tracing paper placed on the LDR, as shown in **Fig. 3.1**.

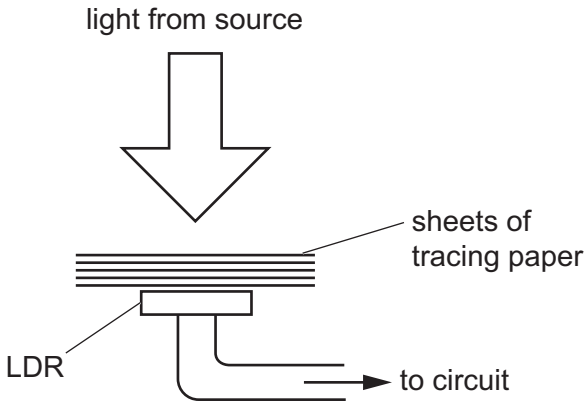

**Fig. 3.1**

Lyla's and Alex's results are shown in **Fig. 3.2**.

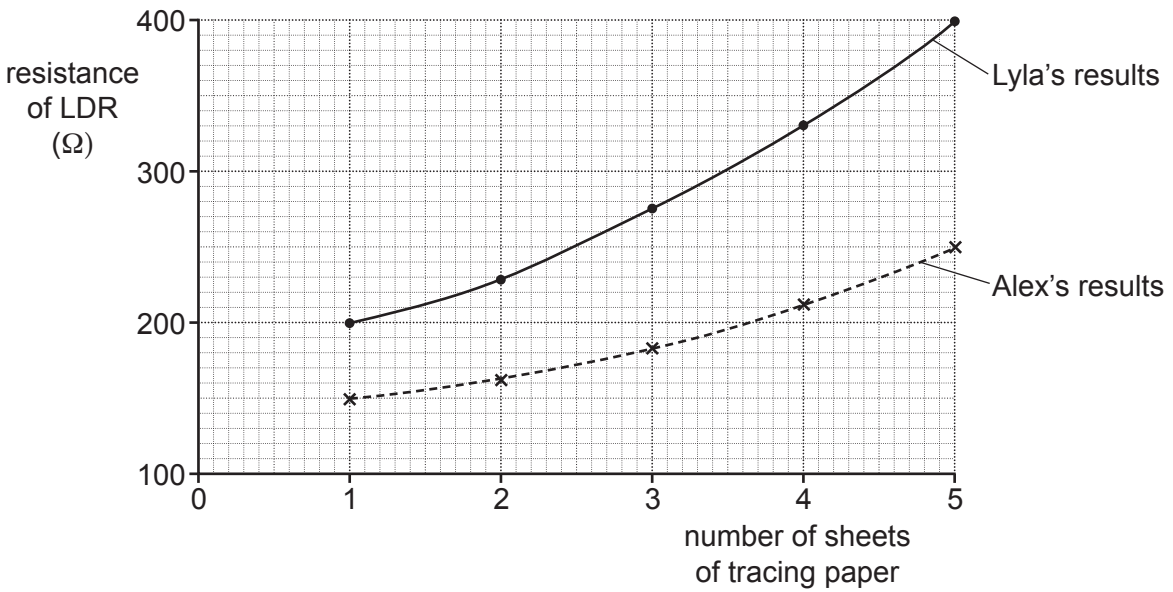

**Fig. 3.2**

- (a) Use **Fig. 3.2** to explain how the **light intensity** affects the resistance of the LDR.

.....

.....

.....

..... [2]

(b) The LDR is connected to a cell, an **ammeter** and a **voltmeter**.

The meter readings from the ammeter and voltmeter are used to determine the resistance of the LDR.

Complete **Fig. 3.3** to show the likely circuit connected by Lyla and Alex.

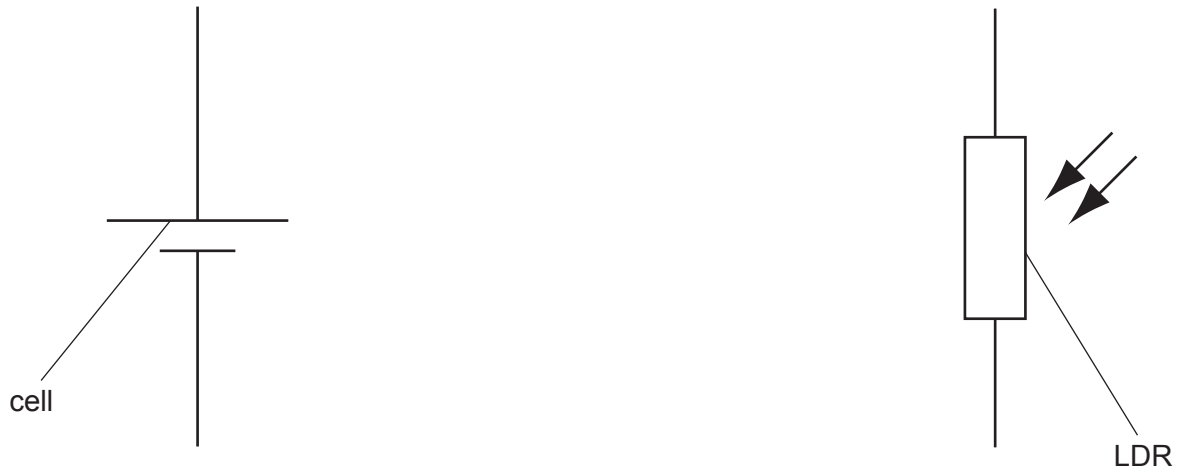

**Fig. 3.3**

[2]

(c) Lyla and Alex worked in different parts of the laboratory to conduct their investigations.

Both used identical sheets of tracing paper and identical LDRs but their results were different.

(i) Suggest **one** thing that must be kept the same to get identical results.

.....  
 ..... [1]

(ii) Suggest **one** improvement that needs to be made to get identical results.

.....  
 ..... [1]

4 Marshmallows are spongy sweets that have tiny pockets of trapped air. Ling is using marshmallows to investigate the relationship between pressure and volume.

(a) Ling places a small marshmallow inside an air-filled plastic syringe. The open end of the syringe is blocked. The syringe has a millilitre (ml) scale.

The volume of the air inside the syringe is increased by moving the plunger to the left.

The temperature of the air inside the syringe remains constant.

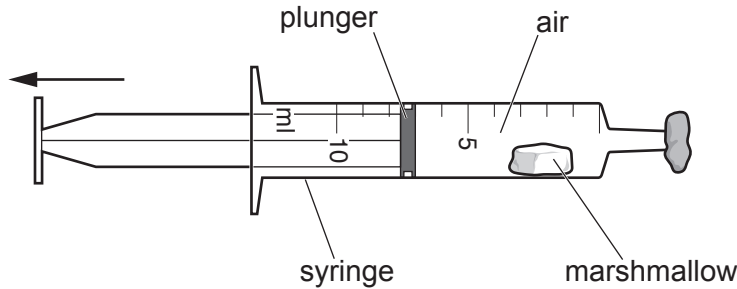

Fig. 4.1

(i) Explain why the marshmallow increases in size when the volume of air inside the syringe is increased.

.....  
.....  
..... [2]

(ii) Ling makes the following hypothesis.

**Ling**  
The length of the marshmallow is directly proportional to the volume of the air in the syringe.



Explain how Ling can take measurements, and analyse the data to check her hypothesis.

.....  
.....  
.....  
..... [3]



(b) Ling has a large fish tank.

Bubbles of air rise through the water from the bottom of the tank, as shown in **Fig. 4.2**.

The volume of a bubble of air **increases** as it rises to the surface of the water.

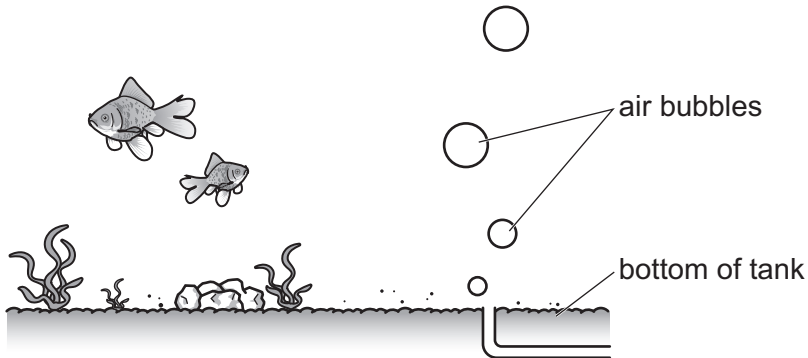

**Fig. 4.2**

Ling has the following information about an air bubble.

	Volume of air bubble ( $\text{mm}^3$ )	Pressure of air inside air bubble (Pa)
<b>Air bubble at surface</b>	8.8	100 000
<b>Air bubble at bottom of tank</b>		110 000

Calculate the volume, in  $\text{mm}^3$ , of the air bubble at the bottom of the tank.

Volume = .....  $\text{mm}^3$  [3]

5 Ultrasound is used in hospitals to image the inside of our bodies.

**Fig. 5.1** shows an ultrasound wave travelling from air into the patient's skin.

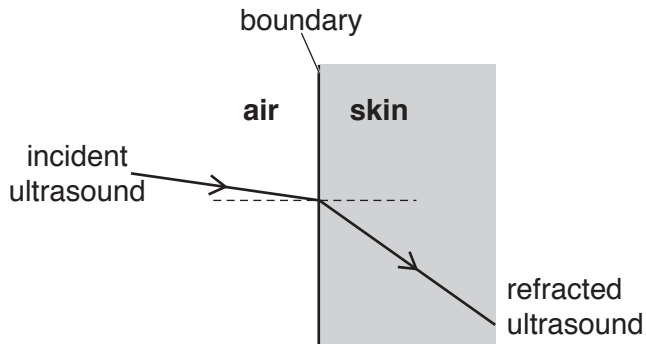

**Fig. 5.1**

The ultrasound wave is **refracted** at the air-skin boundary.

(a) Describe what happens to the **speed**, **frequency** and **wavelength** of the ultrasound wave as it travels from air to skin.

Speed: .....

Frequency: .....

Wavelength: .....

**[3]**

(b) Fig. 5.2 is a diagram of a human eye. Ultrasound can be used to determine the length of an eyeball.

Pulses of ultrasound are sent into the eye.

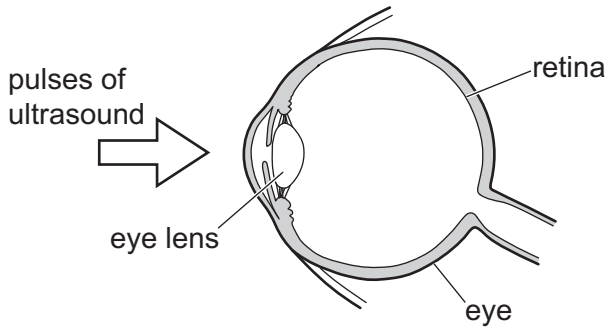

Fig. 5.2

The ultrasound pulse is **reflected** at the retina.

It takes  $4.0 \times 10^{-5}$  s for an ultrasound pulse to travel from the front of the eye, to the retina, and then back to the front of the eye.

The speed of the ultrasound pulse in the eye is 1100 m/s.

Calculate the length of the eyeball in metres.

Length of eyeball = ..... m [4]

(c) Fig. 5.3 shows the ultrasound pulses that were sent into the eye, as described in part (b).

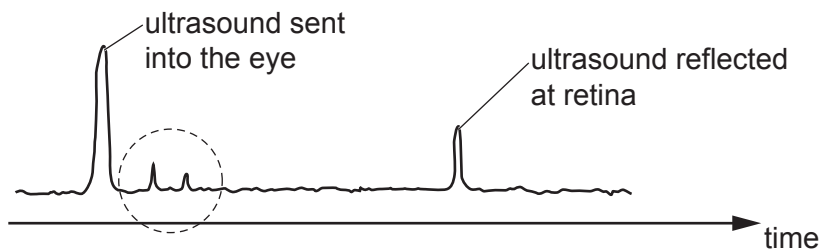

Fig. 5.3

Suggest an explanation for the other two pulses ringed in the diagram.

.....

.....

.....

[2]

6 Kareem is researching replacement bulbs for his grandad.

He finds three types of bulbs – incandescent, compact fluorescent light (CFL) and light-emitting diode (LED).



incandescent

CFL

LED

Table 6.1 shows some information on these bulbs.

	Incandescent	CFL	LED
Power (W)	60	12	8
Life span (hours)	2000	10 000	50 000
CO <sub>2</sub> emissions at power station in 50 000 hours (kg)	1600	330	220

Table 6.1

The three bulbs in Table 6.1 have the **same** brightness.

(a) Kareem makes the following comment about the information in Table 6.1 to his grandad.

**Kareem**  
LED bulbs are the best for you grandad.  
They save the environment and are the most efficient.



Is Kareem correct?

Yes

No

Give **two** reasons for your answer.

1. ....

.....

2. ....

.....

- (b) Calculate the number of **incandescent** bulbs that would be required to do the same job as a single LED bulb, in 50 000 hours.

Use information from **Table 6.1**.

Number of bulbs = ..... [2]

- (c) Calculate the total cost, in pence, of using one **LED bulb** for its lifetime.

The cost of one kWh of energy is 13 p.

Use information from **Table 6.1**.

Total cost = ..... pence [4]

- 7 Eve is investigating the force on a current-carrying wire when it is placed in a magnetic field, as shown in **Fig. 7.1**.

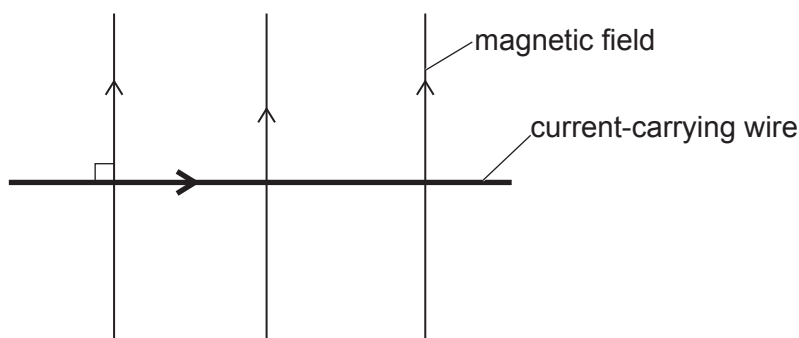

**Fig. 7.1**

The direction of the current in the wire is from left to right.

The magnetic field of the magnet is in the plane of the paper and perpendicular to the current-carrying wire.

The current-carrying wire moves.

- (a) (i) Use Fleming's left-hand rule to predict the **direction** in which the **wire** moves.

Tick (✓) **one** box.

Up along the plane of the paper.

Down along the plane of the paper.

Out of plane of paper.

Into the plane of paper.

[1]

- (ii) Describe how you used Fleming's left-hand rule to find the direction in which the wire moves.

.....

.....

..... [1]

- (b) Explain **why** the current-carrying wire moves.

Use ideas about magnetic fields in your answer.

.....

.....

..... [2]

(c) The current in the wire is 2.0A. The magnetic flux density is 0.060T.

Calculate the force acting on the 4.5cm length of the wire.

Force = ..... N [4]

(d) Explain what happens to the size of the force in (c) when the current in the wire is doubled.

.....  
.....  
..... [2]

8\* Electrical energy is transported across the country using the National Grid.

Transformers play a key role in this transportation.



Describe and explain the role of **transformers** in the transmission of electrical power from power stations to our homes.

You may include a labelled diagram of a transformer.

.....

.....

.....

.....

.....

.....

.....

.....

.....

.....

.....

.....



9 Astronomers use telescopes in space to observe the Universe.

(a) The Kepler telescope has been used to detect planets around distant stars.

It orbits around the Sun in a circular orbit, as shown in Fig. 9.1.

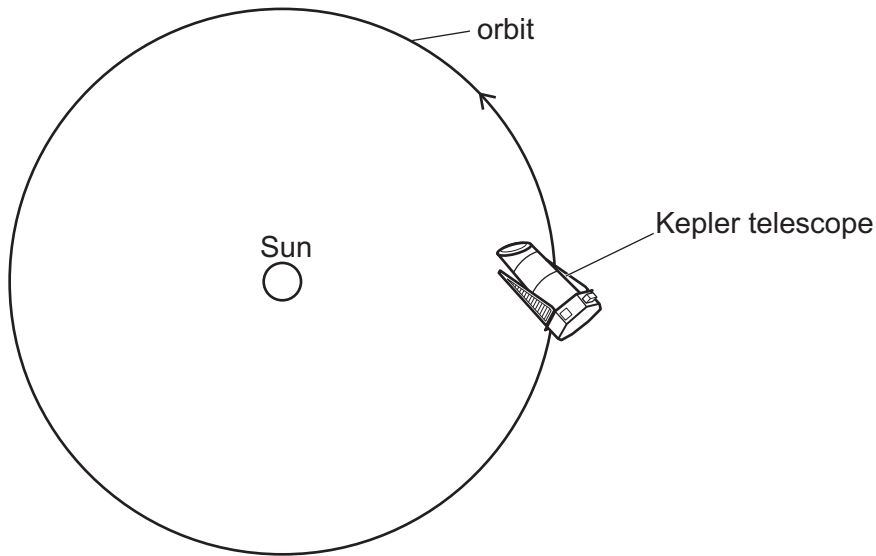

Fig. 9.1

Ben makes the following comment.

**Ben**  
In its orbit, the speed and velocity of the Kepler telescope remains the same.  
  
The force on the Kepler telescope is in the direction of the velocity.



Is Ben correct?

Explain your answer.

.....

.....

.....

..... [2]

(b) The Hubble Space Telescope discovered the Baby Boom Galaxy, where one star is formed every two hours.

(i) Explain how a star is initially formed.

Use ideas from the particle model in your answer.

.....  
.....  
.....  
..... [2]

(ii) Explain the evidence for the 'Big Bang' model of the Universe.

.....  
.....  
.....  
..... [2]

- (c) The Hubble Space Telescope was launched from the surface of the Earth using a reusable rocket (Space Shuttle).

Fig. 9.2 shows the typical forces acting on a rocket during lift-off.

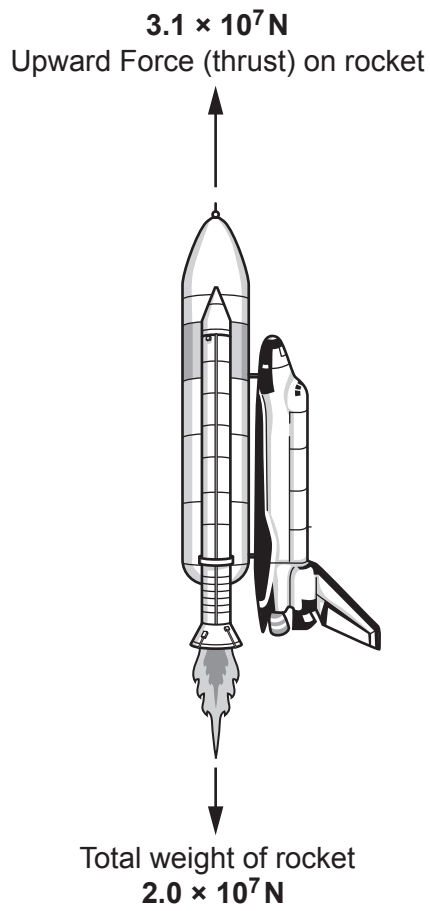

Fig. 9.2

The total mass of the rocket is  $2.0 \times 10^6 \text{ kg}$ .

Calculate the acceleration of the rocket during lift-off.

Acceleration = .....  $\text{m/s}^2$  [4]

10 A delivery company uses GPS tracker devices to monitor the velocity of their vans.

(a) The velocity against time graph of one van is shown in **Fig. 10.1**.

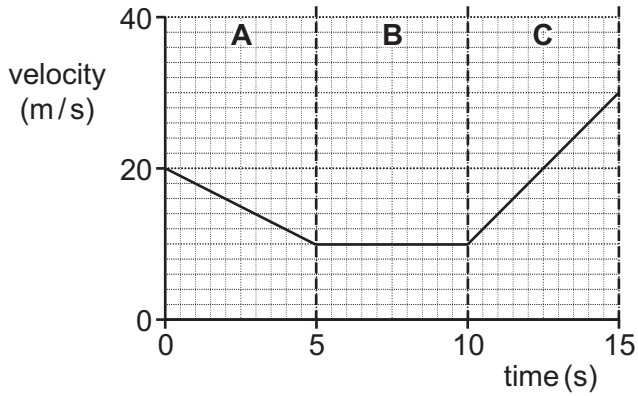

**Fig. 10.1**

**Fig. 10.1** has been divided into three sections **A**, **B** and **C**.

(i) Describe the motion of the van in the three sections.

Section **A**: .....

Section **B**: .....

Section **C**: .....

**[3]**

(ii) Calculate the acceleration of the van in section **C**.

Acceleration = .....  $\text{m/s}^2$  **[3]**

(b) One of the vans collides with a **stationary** car.

(i) **Fig. 10.2** shows the momentum against time graph for the **van**.

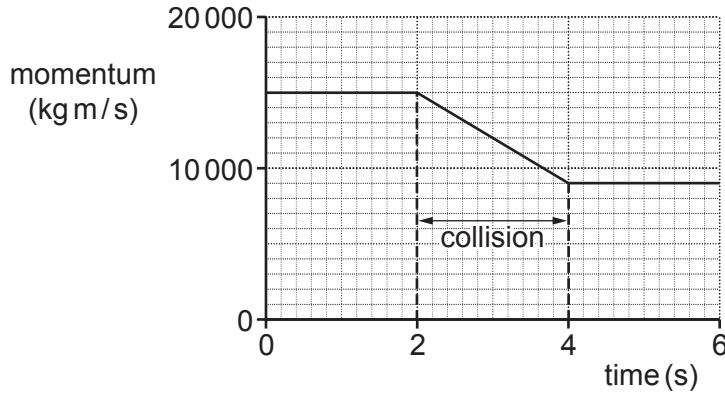

**Fig. 10.2**

Use **Fig. 10.2** to explain why the momentum of the **car** is **6000 kg m/s** immediately after the collision.

.....

.....

.....

..... [2]

The mass of the van is 1500 kg and the mass of the car is 1000 kg.

(ii) Calculate the speed of the car immediately after the collision.

Use the information given in **(b)(i)** to help you answer the question.

Speed = ..... m/s [3]

11 A patient has been diagnosed with a very small cancerous growth on her neck.

A doctor gives the patient a leaflet with information on two possible treatments for her cancer: X-ray radiotherapy and brachytherapy. The information is shown in the table.

	<b>Radiotherapy</b>	<b>Brachytherapy</b>
<b>How are the cancerous cells killed off?</b>	An external beam of X-rays (or gamma rays) is used.	Beta-radiation from material placed in the body is used.
<b>How long does the treatment take?</b>	1 to 2 weeks	6 weeks
<b>Are living cells damaged?</b>	Yes	Yes

(a) The patient and her doctor decide to treat the cancer with **radiotherapy**.

Why did they decide to treat the cancer with radiotherapy?

Use information from the table in your answer.

.....

.....

..... [2]

(b) Radioactive iridium-192 is used for the **brachytherapy** treatment.

The half-life of iridium-192 is 74 days.

The initial activity of the iridium source is  $2.0 \times 10^7$  counts per second.

(i) Sketch a graph to show how the activity of the source changes with time.

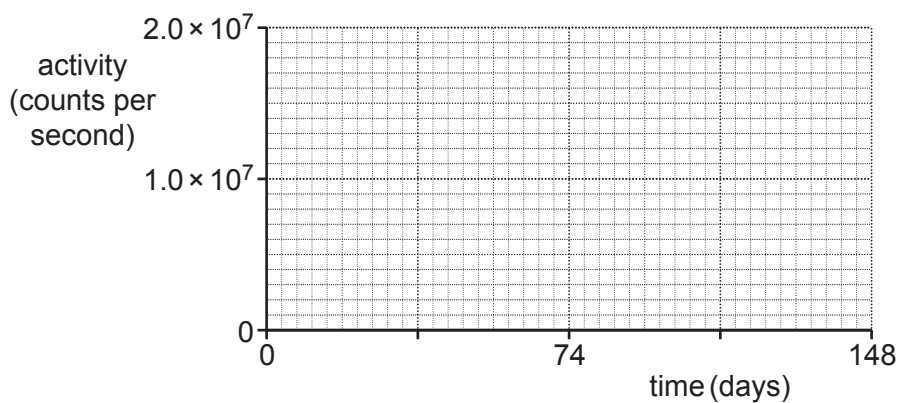

[3]

(ii) The initial activity of another iridium-192 source is **different** from (b)(i).

What fraction of the iridium nuclei are left in the new source after 3 half-lives?

Fraction = ..... [3]

(c) Iridium-192 is a low-level waste product of fission reactions in a nuclear power station.

Low-level wastes, such as Iridium-192, have short half-lives.

Amaya and James are discussing what should happen with low-level wastes like iridium.



**Amaya**  
You can store low-level waste like iridium for some years and then dispose of it as you would any metal.

**James**  
I don't think so, Amaya. It's really dangerous. The low-level waste needs to be locked away forever in deep mines away from any humans.



Who do you agree with? Justify your answer.

.....  
.....  
.....  
..... [2]

**END OF QUESTION PAPER**

**ADDITIONAL ANSWER SPACE**

If additional space is required, you should use the following lined page(s). The question number(s) must be clearly shown in the margin(s).

A large rectangular area with a solid vertical line on the left side and horizontal dotted lines across the rest of the page, providing space for writing answers.



**Copyright Information**

OCR is committed to seeking permission to reproduce all third-party content that it uses in its assessment materials. OCR has attempted to identify and contact all copyright holders whose work is used in this paper. To avoid the issue of disclosure of answer-related information to candidates, all copyright acknowledgements are reproduced in the OCR Copyright Acknowledgements Booklet. This is produced for each series of examinations and is freely available to download from our public website ([www.ocr.org.uk](http://www.ocr.org.uk)) after the live examination series.

If OCR has unwittingly failed to correctly acknowledge or clear any third-party content in this assessment material, OCR will be happy to correct its mistake at the earliest possible opportunity.

For queries or further information please contact The OCR Copyright Team, The Triangle Building, Shaftesbury Road, Cambridge CB2 8EA.

OCR is part of the Cambridge Assessment Group; Cambridge Assessment is the brand name of University of Cambridge Local Examinations Syndicate (UCLES), which is itself a department of the University of Cambridge.