

**Friday 4 November 2016 – Morning**

**GCSE MATHEMATICS B**

**J567/04** Paper 4 (Higher Tier)

Candidates answer on the Question Paper.

**OCR supplied materials:**

None

**Other materials required:**

- Geometrical instruments
- Tracing paper (optional)
- Scientific or graphical calculator

**Duration:** 1 hour 45 minutes



Candidate forename		Candidate surname	
-----------------------	--	----------------------	--

Centre number						Candidate number				
---------------	--	--	--	--	--	------------------	--	--	--	--

### INSTRUCTIONS TO CANDIDATES

- Write your name, centre number and candidate number in the boxes above. Please write clearly and in capital letters.
- Use black ink. HB pencil may be used for graphs and diagrams only.
- Answer **all** the questions.
- Read each question carefully. Make sure you know what you have to do before starting your answer.
- Your answers should be supported with appropriate working. Marks may be given for a correct method even if the answer is incorrect.
- Write your answer to each question in the space provided. Additional paper may be used if necessary but you must clearly show your candidate number, centre number and question number(s).
- Do **not** write in the bar codes.

### INFORMATION FOR CANDIDATES

- The number of marks is given in brackets [ ] at the end of each question or part question.
- Use the  $\pi$  button on your calculator or take  $\pi$  to be 3.142 unless the question says otherwise.
- The quality of written communication is assessed in questions marked with an asterisk (\*).
- The total number of marks for this paper is **100**.
- This document consists of **16** pages. Any blank pages are indicated.

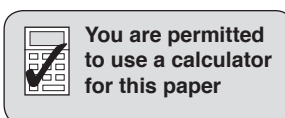

## Formulae Sheet: Higher Tier

**Area of trapezium** =  $\frac{1}{2}(a + b)h$

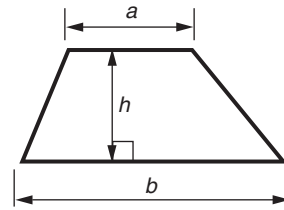

**Volume of prism** = (area of cross-section)  $\times$  length

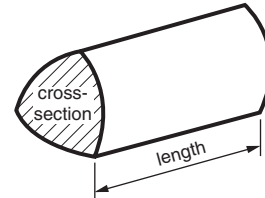

**In any triangle ABC**

**Sine rule**  $\frac{a}{\sin A} = \frac{b}{\sin B} = \frac{c}{\sin C}$

**Cosine rule**  $a^2 = b^2 + c^2 - 2bc \cos A$

**Area of triangle** =  $\frac{1}{2}ab \sin C$

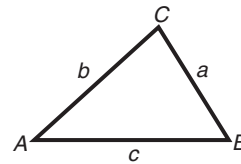

**Volume of sphere** =  $\frac{4}{3}\pi r^3$

**Surface area of sphere** =  $4\pi r^2$

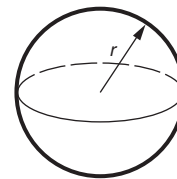

**Volume of cone** =  $\frac{1}{3}\pi r^2 h$

**Curved surface area of cone** =  $\pi r l$

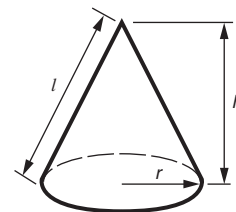

**The Quadratic Equation**

The solutions of  $ax^2 + bx + c = 0$ ,  
where  $a \neq 0$ , are given by

$$x = \frac{-b \pm \sqrt{b^2 - 4ac}}{2a}$$

**PLEASE DO NOT WRITE ON THIS PAGE**

Answer **all** the questions.

- 1 (a) Write 1575 as a product of its prime factors.

..... [3]

- (b) Use your answer to part (a) to show that  $7 \times 1575$  is a square number. [1]

- 2 (a) Complete the table for  $y = x^3 + x - 3$ .

$x$	1	2
$y$		

[2]

- (b) Explain why a solution to  $x^3 + x - 3 = 0$  lies between  $x = 1$  and  $x = 2$ .

.....  
 ..... [1]

- (c) Use trial and improvement to find the solution to  $x^3 + x - 3 = 0$  which lies between  $x = 1$  and  $x = 2$ .  
 Give your answer correct to 1 decimal place.

(c)  $x =$  ..... [3]

3 The table shows the number of dresses that a shop sells in **one week**.

Dress size	10	12	14	16	18+
Number sold	6	8	22	9	5

(a) Find the percentage of the dresses sold that week that were size 14.

(a) ..... % [2]

(b) Complete the table below to show the relative frequency for each dress size.

Dress size	10	12	14	16	18+
Relative frequency	0.12	0.16		0.18	0.10

[1]

(c) The shop owner is going to order 1600 dresses to sell next year.

(i) How many of these dresses should be size 10?

(c)(i) ..... [2]

(ii) What could the owner do to ensure that the answer to part (c)(i) is more reliable?

.....  
 ..... [1]

- 4 (a) The  $n$ th term of a sequence is given by the expression  $5(4n - 3)$ .

Work out the first two terms.

(a) ..... [2]

- (b) Here are the first four terms of another sequence.

-3      6      15      24

Write an expression for the  $n$ th term of this sequence.

(b) ..... [2]

- 5 Solve.

$$6(5x - 3) = 522$$

$x =$  ..... [3]

- 6 Calculate the area of a semicircle with radius 5 cm.  
Give the units of your answer.

..... [3]

- 7 In the diagram, ABC is a triangle and BD is perpendicular to AC.

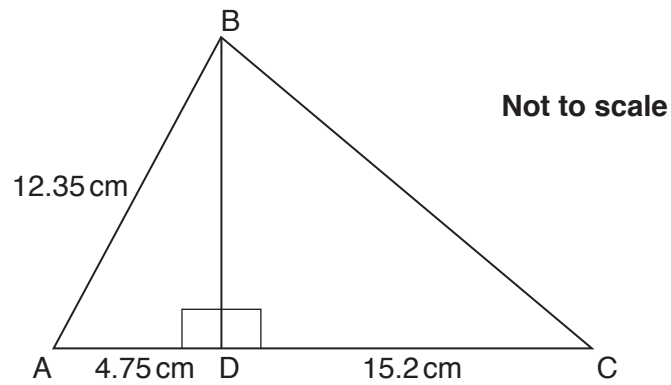

AB = 12.35 cm, AD = 4.75 cm and DC = 15.2 cm.

Work out the length BC.

..... cm [5]

8\* Here is some information about the membership of a tennis club.

- There are 65 members in the club.
- There are 25 male members and 4 of these are left-handed.
- There are 6 left-handed females.

Is the proportion of male members that are left-handed higher than the proportion of female members that are left-handed?

Show how you reached your conclusion.

[6]

9 A regular polygon has an interior angle of  $156^\circ$ .

How many sides has the polygon?

..... [3]

10 A positive integer is represented by  $n$ .

(a) Explain why  $2n + 1$  is always an odd number.

.....  
.....  
..... [2]

(b) Show that the square of an odd number is always odd. [4]



- 11 Anya has £5000 to invest for 3 years.  
She looks at these two accounts with their interest rates.

**Southern Bank Saver**

Annual interest rate:  
Year 1: 2%  
Year 2: 3%  
Year 3: 4%

**Northern Bank Fixed Rate**

Fixed annual rate of 3.5%  
compound interest

Which account will give her the better deal and by how much?

..... [6]

12 The table summarises the distances the employees of company A have to travel to get to work.

Distance to work, $d$ miles	Frequency		
$0 \leq d < 10$	8		
$10 \leq d < 20$	14		
$20 \leq d < 30$	21		
$30 \leq d < 50$	17		

(a) Calculate an estimate of the mean distance travelled to work by these employees.

(a) ..... miles [4]

(b) An employee is selected at random.

Write down the probability that this employee travels less than 20 miles to work.

(b) ..... [2]

(c) The probability that an employee is male is 0.62.

Write down the probability that an employee is female.

(c) ..... [1]

(d) The histogram summarises the distance, in miles, travelled to work by employees of company B.

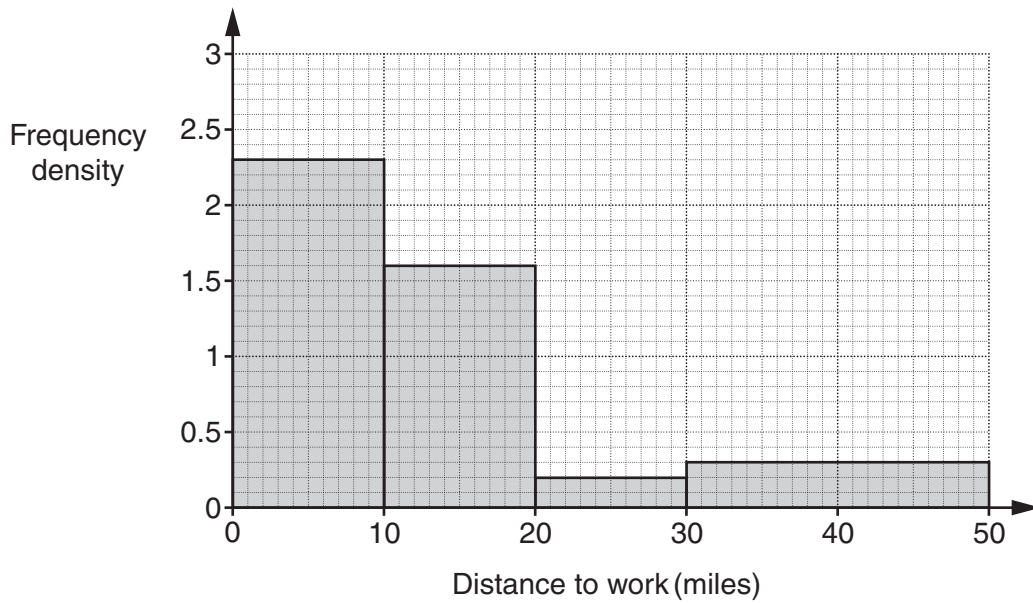

(i) How many employees travel less than 10 miles to work?

(d)(i) ..... [2]

(ii) An employee is selected at random.

Work out the probability that this employee travels less than 20 miles to work.

(ii) ..... [4]

(e) Make two different comments to compare the distances travelled by the employees of company A and company B.

Comment 1

.....  
 .....

Comment 2

.....  
 .....

[2]

13 Triangle ABC has a right angle at B.

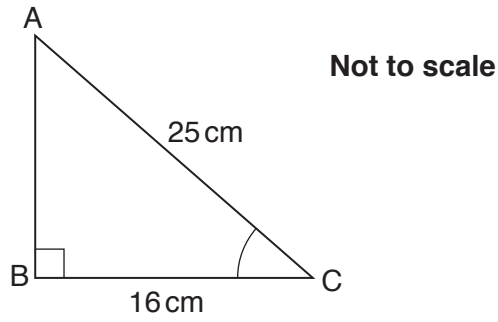

AC = 25 cm and BC = 16 cm.

Calculate angle BCA.

..... ° [3]

14 Solve these simultaneous equations algebraically.

$$\begin{aligned} 3x - 2y &= 17 \\ 4x + 3y &= 17 \end{aligned}$$

$x =$  .....

$y =$  ..... [4]

15 Make  $x$  the subject of the following.

(a)  $y = 5x^2 - 4$

(a) ..... [3]

(b)  $5x - 2y = x + 18$

(b) ..... [3]

16 There are 312 passengers in an aeroplane.

There are 167 male passengers.

The airline assumes each male weighs 84 kg and each female weighs 68 kg. Both weights are given correct to the nearest kilogram.

The maximum total weight of all the passengers must not exceed 24 tonnes.

(1 tonne = 1000 kg)

(a) Using the airline's assumptions, show that the total weight of all the passengers on this aeroplane could exceed the maximum allowed. [4]

(b) Explain why the airline's assumption may not be sensible.

.....  
..... [1]

17 Write  $x^2 - 8x + 28$  in the form  $(x + a)^2 + b$ .

..... [3]

18 ABC is an isosceles triangle with  $AB = CB$ .

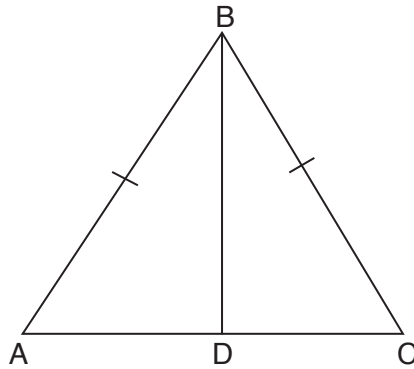

Not to scale

Line BD bisects the angle at B.

(a) Prove that triangles ABD and CBD are congruent.  
Give reasons for the statements you make.

[4]

(b) Hence prove that angle ADB is  $90^\circ$ .

..... [2]

19 The diagram shows the frustum of a cone.

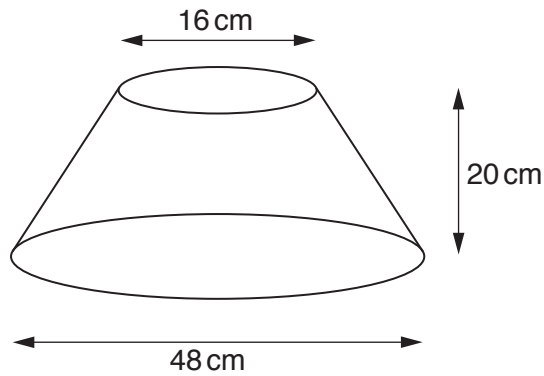

The radius of the base is 24 cm and the radius of the top is 8 cm.  
The perpendicular height is 20 cm.

Calculate the volume of the frustum.

..... cm<sup>3</sup> [6]

**END OF QUESTION PAPER**

**OCR**  
Oxford Cambridge and RSA

**Copyright Information**

OCR is committed to seeking permission to reproduce all third-party content that it uses in its assessment materials. OCR has attempted to identify and contact all copyright holders whose work is used in this paper. To avoid the issue of disclosure of answer-related information to candidates, all copyright acknowledgements are reproduced in the OCR Copyright Acknowledgements Booklet. This is produced for each series of examinations and is freely available to download from our public website ([www.ocr.org.uk](http://www.ocr.org.uk)) after the live examination series. If OCR has unwittingly failed to correctly acknowledge or clear any third-party content in this assessment material, OCR will be happy to correct its mistake at the earliest possible opportunity.

For queries or further information please contact the Copyright Team, First Floor, 9 Hills Road, Cambridge CB2 1GE.

OCR is part of the Cambridge Assessment Group; Cambridge Assessment is the brand name of University of Cambridge Local Examinations Syndicate (UCLES), which is itself a department of the University of Cambridge.