



Oxford Cambridge and RSA

Monday 20 May 2019 – Afternoon

A Level Physics A

H556/01 Modelling physics

Time allowed: 2 hours 15 minutes



You must have:

- the Data, Formula and Relationships Booklet (sent with general stationery)

You may use:

- a scientific or graphical calculator
- a ruler (cm/mm)



Please write clearly in black ink. **Do not write in the barcodes.**

Centre number

--	--	--	--	--

Candidate number

--	--	--	--

First name(s)

Last name

INSTRUCTIONS

- Use black ink. You may use an HB pencil for graphs and diagrams.
- Answer **all** the questions.
- Where appropriate, your answers should be supported with working. Marks may be given for a correct method even if the answer is incorrect.
- Write your answer to each question in the space provided. If additional space is required, use the lined page(s) at the end of this booklet. The question number(s) must be clearly shown.

INFORMATION

- The total mark for this paper is **100**.
- The marks for each question are shown in brackets [].
- Quality of extended responses will be assessed in questions marked with an asterisk (*).
- This document consists of **32** pages.

2
SECTION A

You should spend a maximum of 30 minutes on this section.

Write your answer to each question in the box provided.

Answer **all** the questions.

1 Which set of prefixes **A**, **B**, **C** or **D** are in order of **increasing** magnitude?

A micro, milli, centi, kilo

B milli, centi, micro, kilo

C kilo, centi, milli, micro

D centi, micro, milli, kilo

Your answer

[1]

2 A paper cone is held above the ground and dropped. It falls vertically and reaches terminal velocity before it hits the ground.

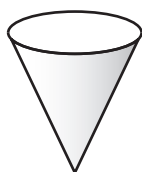

Which statement correctly describes the **resultant** force on the falling cone before it reaches terminal velocity?

A decreasing and upwards

B decreasing and downwards

C increasing and downwards

D increasing and upwards

Your answer

[1]

- 3 A solid cylindrical glass rod has length 20.0 ± 0.1 cm and diameter 5.00 ± 0.01 mm.

What is the percentage uncertainty in the calculated volume of this rod?

- A 0.1%
- B 0.2%
- C 0.7%
- D 0.9%

Your answer

[1]

- 4 A simple harmonic oscillator has maximum speed 24 m s^{-1} and amplitude 5.6 cm.

What is its angular frequency?

- A 0.23 rad s^{-1}
- B 21 rad s^{-1}
- C 68 rad s^{-1}
- D 430 rad s^{-1}

Your answer

[1]

- 5 A car is dripping oil at a steady rate on a straight road. The road is divided into four sections **A**, **B**, **C**, and **D**.

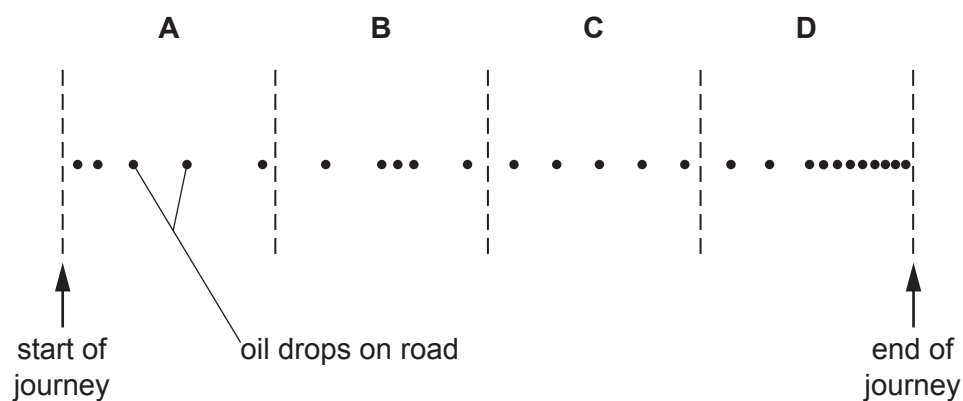

Which section of the road shows the car travelling at a constant speed?

Your answer

[1]

- 6 The Earth is surrounded by a gravitational field.

Which of the following statements is/are correct about the gravitational field lines near the **surface** of the Earth.

- 1 They are parallel.
- 2 They show the direction of the force on a small mass.
- 3 They are equally spaced.

- A Only 1
 B Only 1 and 2
 C Only 2 and 3
 D 1, 2 and 3

Your answer

[1]

- 7 A pendulum bob is oscillating in a vacuum.
 The maximum height of the bob from the ground is 1.3 m and its minimum height is 1.1 m.

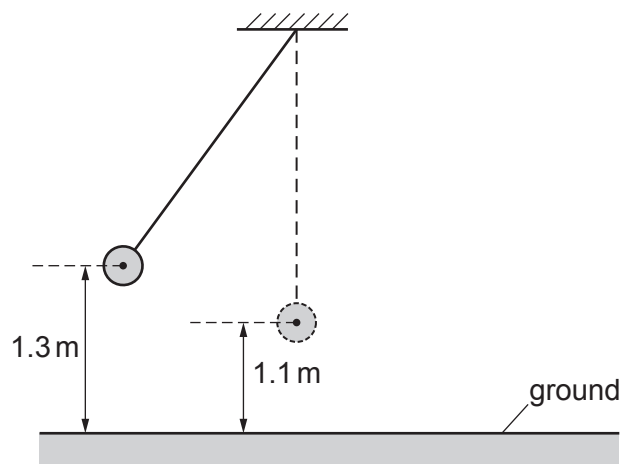

What is the maximum speed of the pendulum bob?

- A 2.0 ms^{-1}
 B 3.9 ms^{-1}
 C 5.1 ms^{-1}
 D 26 ms^{-1}

Your answer

[1]

- 8 An object is falling.
The weight of the object is 4.5 N.
The wind provides a horizontal force of magnitude F on the object.
The **resultant** force on the object is 5.8 N.
Air resistance and upthrust on the object are negligible.

What is the value of F ?

- A 1.3 N
- B 3.7 N
- C 7.3 N
- D 13 N

Your answer

[1]

- 9 A solid molecular substance is supplied with energy and it starts to melt.

Which of the following pairs of quantities remains the same as the substance melts?

- A Kinetic energy of molecules and internal energy of molecules.
- B Potential energy of molecules and internal energy of molecules.
- C Kinetic energy of molecules and temperature of substance.
- D Potential energy of molecules and temperature of substance.

Your answer

[1]

- 10 Which of the following shows the correct base units for pressure?

- A kg m^{-2}
- B $\text{kg m}^{-2} \text{s}^{-2}$
- C $\text{kg m}^{-1} \text{s}^{-2}$
- D $\text{kg m}^2 \text{s}^{-3}$

Your answer

[1]

- 11 A student has collected some data on the Solar System.
The student plots a graph, but only two data points are shown below.



The distance from the centre of the Sun is r .

Which quantity y is represented on the vertical axis?

- A Speed of a planet.
- B Period of a planet.
- C Gravitational potential of the Sun.
- D Gravitational field strength of the Sun.

Your answer

[1]

12 A graph showing the variation of the stress σ with strain ϵ for a material is shown below.

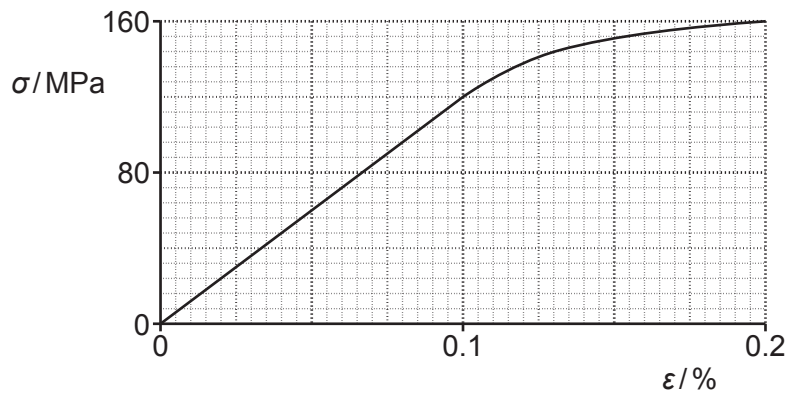

What is the Young modulus of the material?

- A 6.0×10^4 Pa
- B 1.2×10^9 Pa
- C 8.0×10^{10} Pa
- D 1.2×10^{11} Pa

Your answer

[1]

13 Which column **A**, **B**, **C** or **D**, shows the correct sequence for the evolution of the Universe between the Big Bang and the formation of stars?

A	B	C	D
Universe starts to expand ↓ quarks and leptons form ↓ hadrons form ↓ nuclei form ↓ atoms form	Universe starts to expand ↓ hadrons form ↓ quarks and leptons form ↓ nuclei form ↓ atoms form	quarks and leptons form ↓ nuclei form ↓ Universe starts to expand ↓ atoms form ↓ hadrons form	quarks and leptons form ↓ hadrons form ↓ Universe starts to expand ↓ nuclei form ↓ atoms form

Your answer

[1]

- 14 Some stars will evolve into white dwarfs.
The mass of the Sun is 2.0×10^{30} kg.

Which of the following **cannot** be the mass of a white dwarf?

- A 1.2×10^{30} kg
- B 2.0×10^{30} kg
- C 2.7×10^{30} kg
- D 3.2×10^{30} kg

Your answer

[1]

- 15 An astronomer analyses the light from a distant galaxy.
One of the spectral lines in the spectrum observed from the galaxy has wavelength 610 nm.
The same spectral line has a wavelength of 590 nm when measured in the laboratory.

What is the speed of this galaxy?

- A 9.8×10^6 ms⁻¹
- B 1.0×10^7 ms⁻¹
- C 2.9×10^8 ms⁻¹
- D 3.0×10^8 ms⁻¹

Your answer

[1]

PLEASE DO NOT WRITE ON THIS PAGE

Question 16 begins on page 10

10
SECTION B

Answer **all** the questions.

- 16 (a) Explain what is meant by the **ultimate tensile strength** of a material.

.....
..... [1]

- (b) A footbridge is supported by a number of metal cables of the same length. Each cable has uniform cross-section and diameter 4.20 mm as shown in Fig. 16.1.

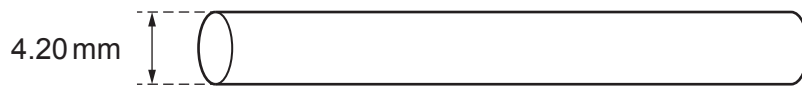

Fig. 16.1 (not to scale)

A group of engineers investigate how the extension x varies with applied force F for one of the cables.

The results of the investigation are shown in Fig. 16.2.

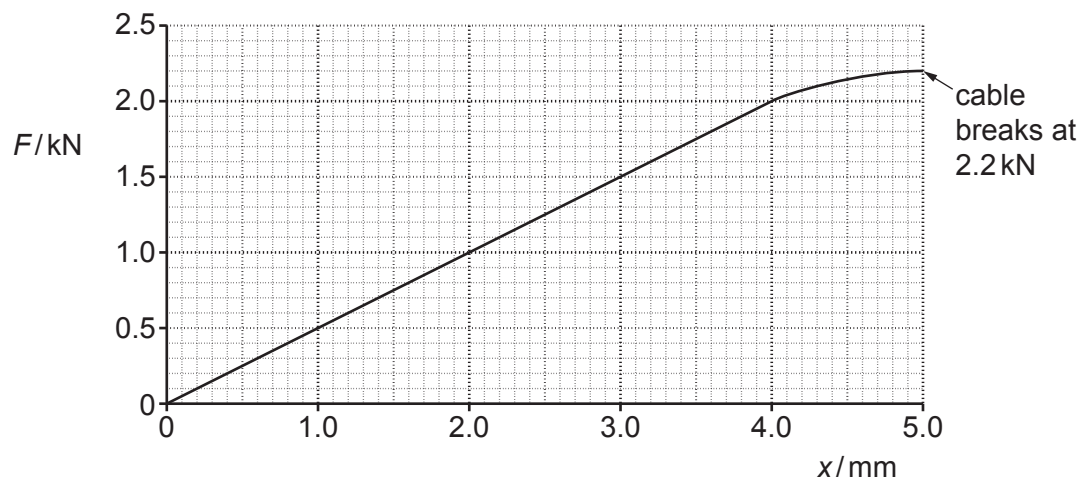

Fig. 16.2

The cable breaks when the force is 2.2 kN.

- (i) Describe how a suitable measuring device may have been used by the engineers to demonstrate that the cable had uniform cross-section.

.....
.....
..... [2]

(ii) State any value of F when the cable behaves

1. elastically

$F = \dots\dots\dots$ kN

2. plastically.

$F = \dots\dots\dots$ kN
[2]

(iii) Use Fig. 16.2 to determine the force constant k in Nm^{-1} of the cable.

$k = \dots\dots\dots$ Nm^{-1} [2]

(c) Determine the breaking stress σ of the cable.

Assume that the cross-sectional area of the cable remains constant during the test.

$\sigma = \dots\dots\dots$ Pa [2]

(d) Explain why the work done on the cable when its extension changes from 3.0 mm to 4.0 mm is greater than when its extension changes from 1.0 mm to 2.0 mm.

.....

 [2]

- 17 A student uses a motion-sensor connected to a laptop to investigate the motion of a hollow ball of mass $1.2 \times 10^{-2} \text{ kg}$ falling through air.

The ball is dropped from rest. It reaches terminal velocity before it reaches the ground.

The upthrust on the ball is negligible.

Fig. 17 shows the variation with time t of the velocity v of the ball as it falls towards the ground.

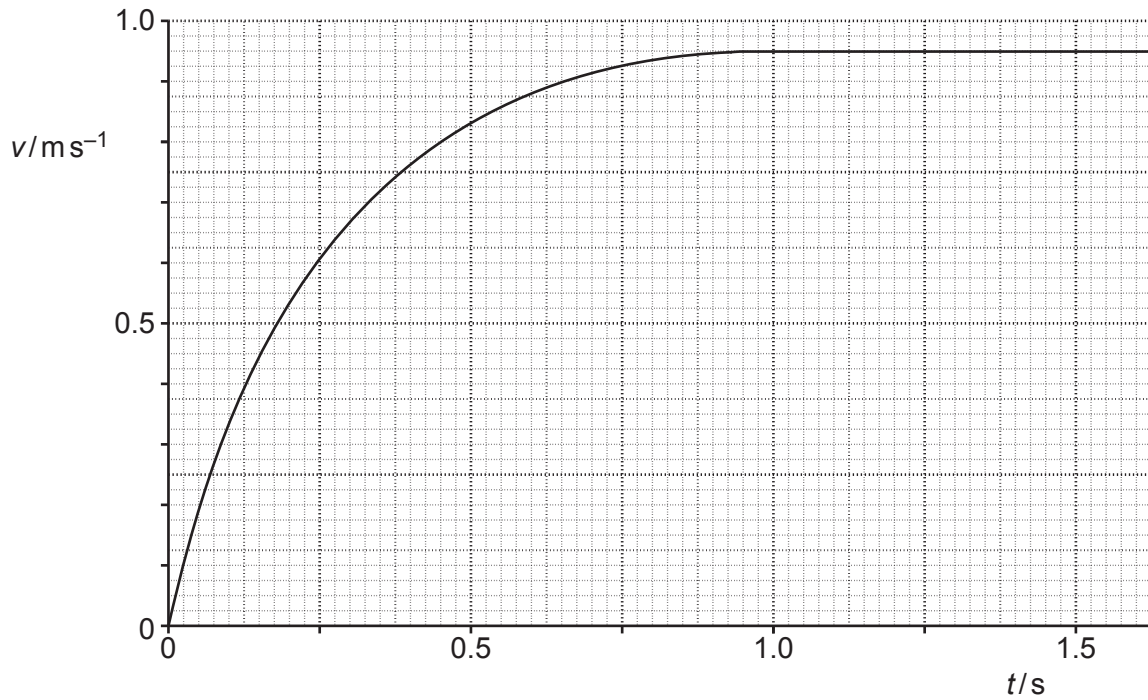

Fig. 17

- (a) Draw a tangent to the curve at $t = 0.25 \text{ s}$ and determine the acceleration of the ball.

acceleration = ms^{-2} [3]

- (b) Calculate the resultant force F acting on the ball at $t = 0.25$ s.

$$F = \dots\dots\dots \text{ N [1]}$$

- (c) Use your answer in (b) to calculate the drag on the ball at time $t = 0.25$ s.

$$\text{drag} = \dots\dots\dots \text{ N [3]}$$

- (d) The student now adds a small amount of sand inside the hollow ball.
As before, the ball is dropped from rest and it also reaches terminal velocity before it reaches the ground.

- (i) Describe how the forces acting on the sand-filled ball at $v = 0.50 \text{ m s}^{-1}$ compare with the forces acting on the hollow ball at this speed.

.....

 [2]

- (ii) Explain why the terminal velocity of the sand-filled ball will be greater than the terminal velocity of the hollow ball.

.....

 [2]

- 18 A mass hanging from a vertical spring is pulled down. It is then released from rest at time $t = 0$. The mass oscillates vertically in a **vacuum** with simple harmonic motion about the equilibrium position. The spring is in tension at all times.

Fig. 18.1 shows the position of the mass at $t = 0$.

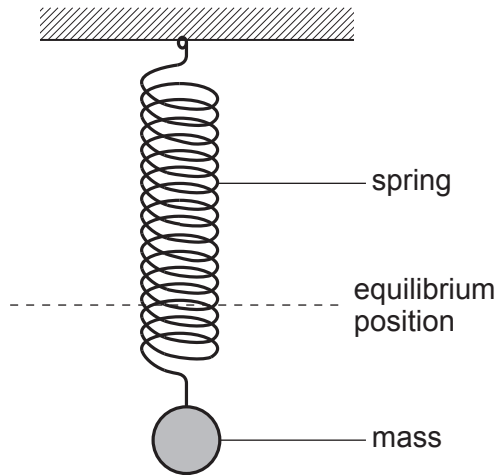

Fig. 18.1

At time $t = 6.5\text{ s}$ the magnitude of the acceleration a of the mass is 3.6 m s^{-2} and its displacement x is $4.6 \times 10^{-2}\text{ m}$.

- (a) (i) Use the defining equation for simple harmonic motion to show that the natural frequency f_0 of the mass-spring system is about 1.4 Hz.

[3]

(ii) Calculate the amplitude A of the oscillations.

$A = \dots\dots\dots$ m [2]

(b) The mass-spring system shown in Fig. 18.1 is now made to oscillate in air.

Different types of energy are involved in the oscillations of this mass-spring system.

Describe the energy changes that will take place as the mass moves from the lowest point in its motion through the equilibrium position to the highest point in its motion.

.....
.....
.....
.....
.....
.....
.....
.....
.....
.....
..... [4]

Question 18 continues on page 16

- (c) Fig. 18.2 shows the mass and spring now attached to a mechanical vibrator, which can oscillate with variable frequency.

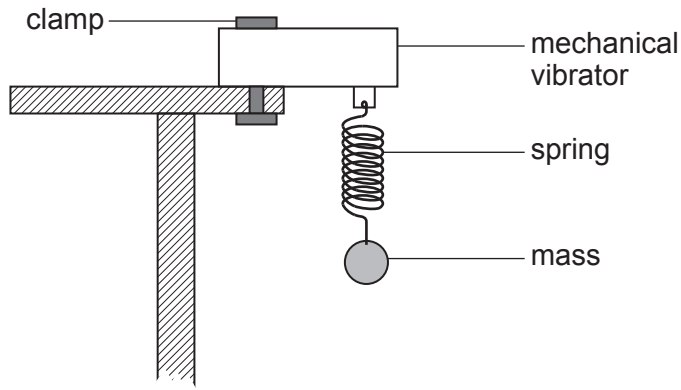

Fig. 18.2

The mass oscillates in air.

- (i) The vibrator frequency is varied from 0 Hz to 2.5 Hz. On Fig. 18.3, sketch a graph to show the variation with vibrator frequency of the amplitude of the mass. Label your graph **K**.

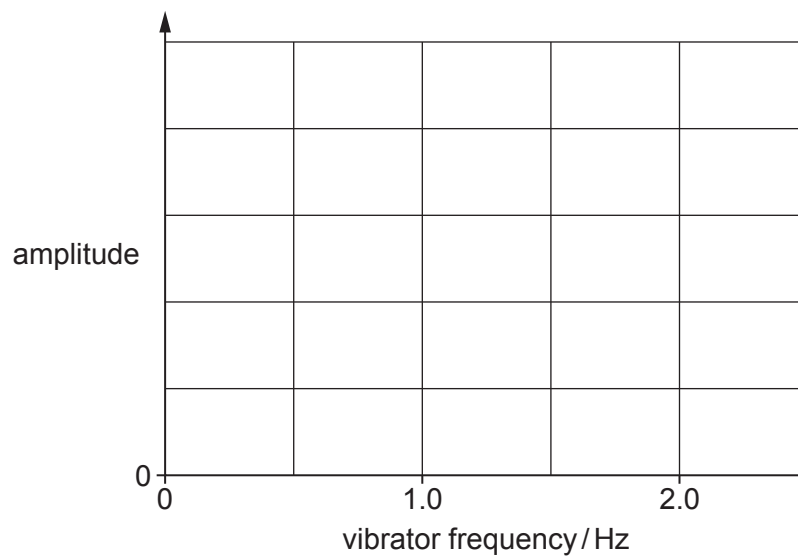

Fig. 18.3

[2]

- (ii) A light disc is now attached to the mass to increase the damping. The vibrator frequency is again varied from 0 Hz to 2.5 Hz. Sketch a second graph on Fig. 18.3 to show the new variation of the amplitude. Label this graph **D**.

[1]

(iii) Explain why the phenomenon demonstrated in this experiment can cause problems for engineers when designing suspended footbridges.

.....

.....

.....

..... [2]

- 19 (a) A car is travelling along a straight road at 18 m s^{-1} .
The driver sees an obstacle and after 0.50 s applies the brakes.
The **stopping** distance of the car is 38 m.

Calculate the magnitude of the deceleration of the car when the brakes are applied.

deceleration = m s^{-2} [3]

- (b)* A student rolls a marble at different speeds on a carpet to model the braking of a car.

The student wishes to investigate how the total distance x travelled before the marble stops (braking distance) depends on its initial speed v .

The speed v and distance x are related by the equation $\frac{1}{2}mv^2 = Fx$ where m is the mass of the marble and F is the constant frictional force acting on the marble.

- Describe how an experiment can be conducted in the laboratory to investigate the relationship between v and x .
- Explain how the data can be analysed to determine F . [6]

.....

.....

.....

.....

.....

.....

.....

.....

.....

.....

.....

.....

.....

.....

.....

.....

Additional answer space if required.

.....

.....

.....

.....

.....

.....

.....

.....

.....

.....

.....

.....

.....

.....

.....

.....

.....

.....

.....

.....

.....

.....

.....

- 20 A bicycle manufacturer carries out tests on the braking system of their new model. A cyclist on this new bicycle travels at a constant initial speed U . The cyclist applies the brakes at time $t = 0$ and the bicycle comes to a stop at time $t = 2.0$ s.

Fig. 20.1 shows the variation of the braking force F on the bicycle with time t .

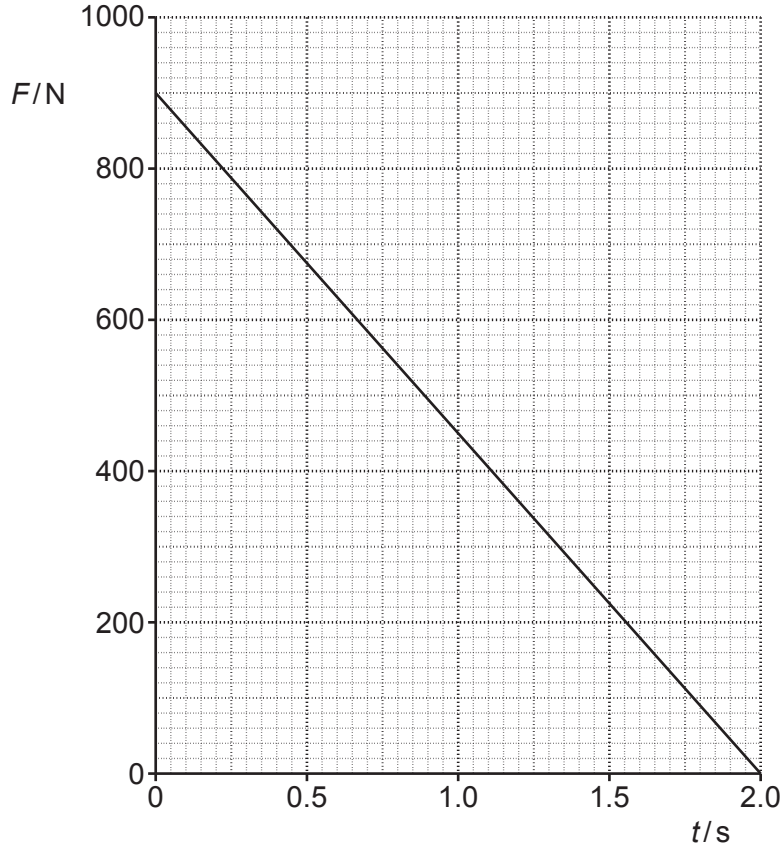

Fig. 20.1

- (a) Use Newton's second law of motion to explain the physical quantity represented by the area under the graph shown in Fig. 20.1.

.....

.....

..... [2]

(b) The total mass of cyclist and bicycle is 71 kg.

Use Fig. 20.1 to calculate the initial speed U .

$$U = \dots\dots\dots \text{ms}^{-1} \text{ [2]}$$

(c) Complete Fig. 20.2 to show the variation of the speed of the bicycle from $t = 0$ to $t = 2.0$ s.

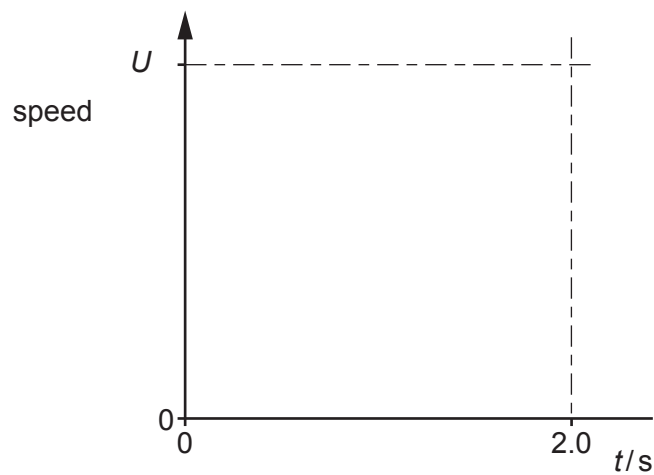

Fig. 20.2

[2]

- 21 A substance can exist as a crystalline solid, a liquid or a gas.
 A solid sample of the substance is placed in a sealed container and heated at a constant rate until it changes into a gas.

Fig. 21 shows the variation with time t of the temperature θ for the substance.

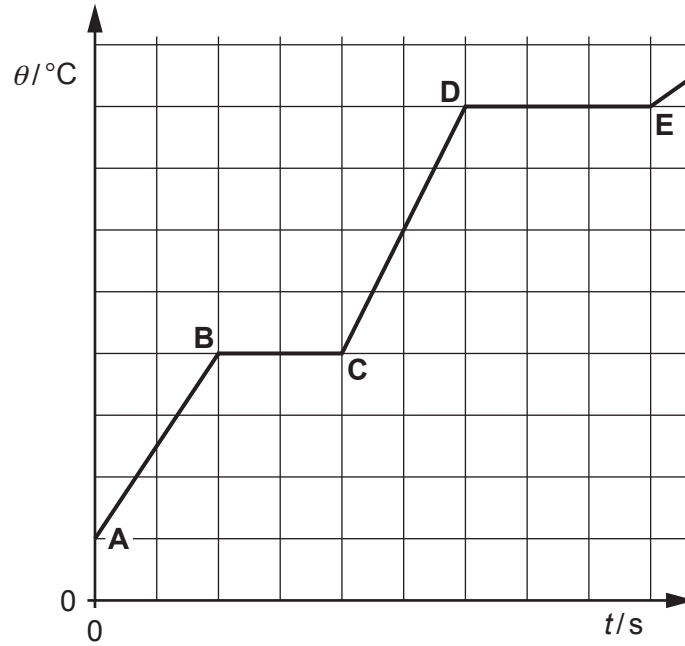

Fig. 21

- (a) Use the kinetic theory of matter to describe the solid phase (section **AB**) and the liquid phase (section **CD**) in terms of the motion and arrangement of the molecules of the substance.

Section **AB**:

.....

.....

.....

.....

.....

.....

Section **CD**:

.....

.....

.....

.....

.....

[4]

- (b) Use Fig. 21 to explain how the specific heat capacity of the liquid compares with the specific heat capacity of the solid.

.....

 [2]

- (c) State what is meant by the **internal energy** of the substance.

.....

 [1]

- (d) Beyond the point **E** in Fig. 21, the substance behaves as an ideal gas.

- (i) The mass of a gas molecule is 4.8×10^{-26} kg.
 Calculate the root mean square speed of the gas molecules at a temperature of 250°C .

root mean square speed = ms^{-1} [3]

- (ii) Calculate the internal energy of 1.3 moles of the gas at 250°C .

internal energy = J [3]

22 A screw is used to hang a wooden sign on a wall. It is screwed into the wall using a screwdriver.

- (a) The width of the screwdriver blade is 5.0×10^{-3} m from end to end. The ends of the blade exert equal and opposite forces on the screw. The magnitude of each force is 350 N, as shown in Fig. 22.1.

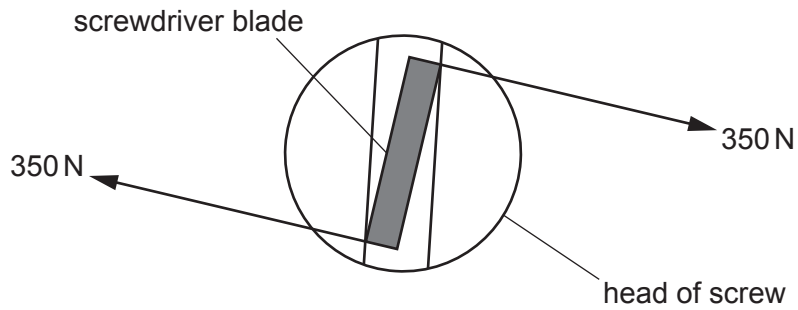

Fig. 22.1

Calculate the magnitude of the torque of the couple produced by the forces at each end of the screwdriver blade.

torque = Nm [1]

- (b) The wooden sign is then hung on the screw at point **A**. The forces acting on the screw are shown in Fig. 22.2.

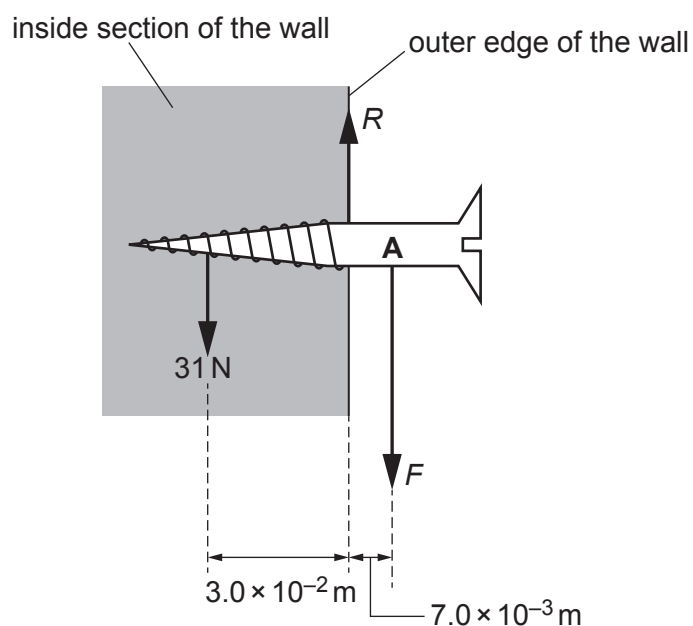

Fig. 22.2

The inside section of the wall exerts a maximum downwards force of 31 N at a distance of $3.0 \times 10^{-2}\text{ m}$ from the outer edge of the wall.

The hanging wooden sign exerts a force F at a distance $7.0 \times 10^{-3}\text{ m}$ from the outer edge of the wall.

There is a force R acting on the screw at the outer edge of the wall.

The mass of the screw is negligible.

Use the principle of moments to calculate the maximum mass of the wooden sign.

mass = kg [3]

.....

.....

.....

.....

Additional answer space if required.

.....

.....

.....

.....

.....

.....

.....

.....

.....

.....

.....

.....

.....

.....

.....

.....

.....

.....

.....

.....

Question 23 continues on page 28

(b) Kepler's third law can be applied to a satellite in a geostationary orbit around the Earth.

- (i) Complete the equation for Kepler's third law below.
You do not need to define any of the terms.

$$\dots\dots\dots = \frac{4\pi^2}{GM} \dots\dots\dots$$

[1]

- (ii) The mass of Earth is 6.0×10^{24} kg.
Calculate the radius of the circular path of a satellite in a geostationary orbit around the Earth.

radius = m [2]

- 24 (a) Proxima Centauri is the closest star to Earth.
Fig. 24.1 shows the apparent positions of this star against the background of very distant stars as seen from the Earth over a period of exactly 6 months.

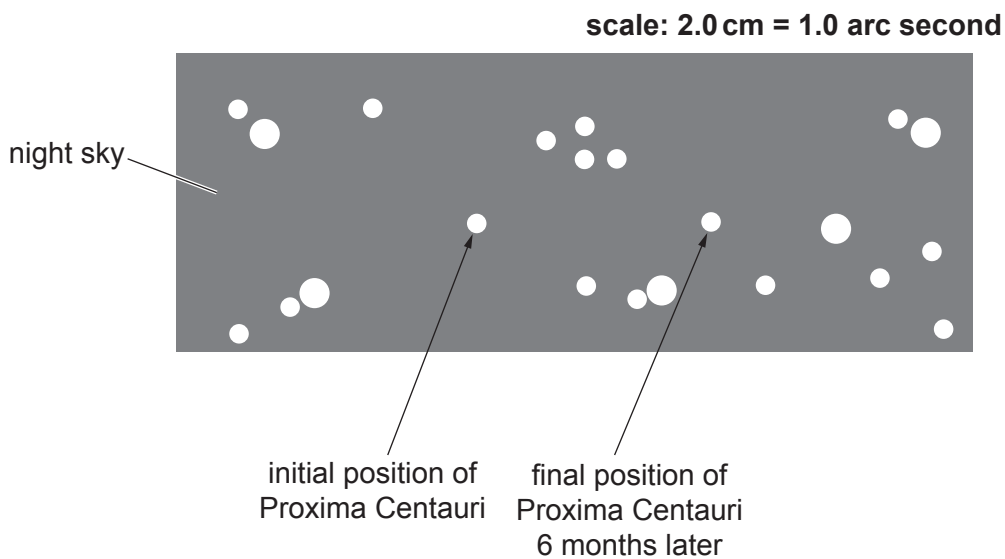

Fig. 24.1

The parallax angle for Proxima Centauri can be determined from Fig. 24.1 using the scale provided.

- (i) Show that the parallax angle p for Proxima Centauri is about 0.8 arc second.

[2]

Question 24 continues on page 30

- (ii) Use your answer in (i) to calculate the distance d of Proxima Centauri from the Earth in light-years (ly).

$$1 \text{ pc} = 3.26 \text{ ly}$$

$$d = \dots\dots\dots \text{ ly [2]}$$

- (b) The galaxies in the Universe may be assumed to be distributed uniformly through space.

In this model, the separation between two neighbouring galaxies is $1.4 \times 10^{23} \text{ m}$ and each galaxy occupies a cube of space of volume $2.7 \times 10^{69} \text{ m}^3$ as shown in Fig. 24.2.

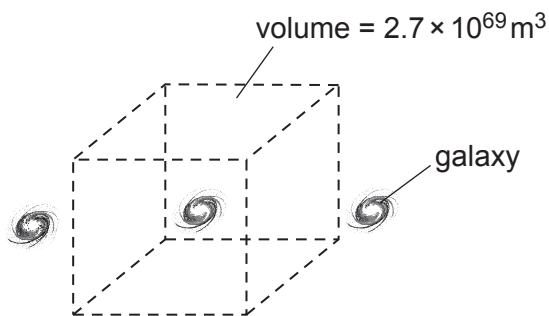

Fig. 24.2

There are on average 10^{11} stars in each galaxy and the mass of an average star is about $2.0 \times 10^{30} \text{ kg}$.

- (i) Estimate the gravitational force between two neighbouring galaxies.

force = N [2]

- (ii) Show that the mean density of the Universe is about $7 \times 10^{-29} \text{ kg m}^{-3}$.

[1]

- (iii) Suggest why the actual mean density of the Universe is different from the value calculated in (ii).

.....
..... [1]

END OF QUESTION PAPER

ADDITIONAL ANSWER SPACE

If additional space is required, you should use the following lined page(s). The question number(s) must be clearly shown in the margin(s).

A large rectangular area with a solid vertical line on the left side and horizontal dotted lines across the rest of the page, providing space for writing answers.



Copyright Information

OCR is committed to seeking permission to reproduce all third-party content that it uses in its assessment materials. OCR has attempted to identify and contact all copyright holders whose work is used in this paper. To avoid the issue of disclosure of answer-related information to candidates, all copyright acknowledgements are reproduced in the OCR Copyright Acknowledgements Booklet. This is produced for each series of examinations and is freely available to download from our public website (www.ocr.org.uk) after the live examination series. If OCR has unwittingly failed to correctly acknowledge or clear any third-party content in this assessment material, OCR will be happy to correct its mistake at the earliest possible opportunity.

For queries or further information please contact The OCR Copyright Team, The Triangle Building, Shaftesbury Road, Cambridge CB2 8EA.

OCR is part of the Cambridge Assessment Group; Cambridge Assessment is the brand name of University of Cambridge Local Examinations Syndicate (UCLES), which is itself a department of the University of Cambridge.