

**A Level Physics A**  
**H556/03 Unified physics**  
Sample Question Paper

**Date – Morning/Afternoon**

Version 2.0

Time allowed: 1 hour 30 minutes



**You must have:**

- the Data, Formulae and Relationships Booklet

**You may use:**

- a scientific or graphical calculator



<b>First name</b>										
<b>Last name</b>										
<b>Centre number</b>										
<b>Candidate number</b>										

**INSTRUCTIONS**

- Use black ink. You may use an HB pencil for graphs and diagrams.
- Complete the boxes above with your name, centre number and candidate number.
- Answer **all** the questions.
- Where appropriate, your answers should be supported with working. Marks may be given for a correct method even if the answer is incorrect.
- Write your answer to each question in the space provided.
- Additional paper may be used if required but you must clearly show your candidate number, centre number and question number(s).
- Do **not** write in the bar codes.

**INFORMATION**

- The total mark for this paper is **70**.
- The marks for each question are shown in brackets [ ].
- Quality of extended responses will be assessed in questions marked with an asterisk (\*).
- This document consists of **20** pages.

Answer **all** the questions

- 1 This question is about the operation of an electrically powered shower designed by an electrical firm.

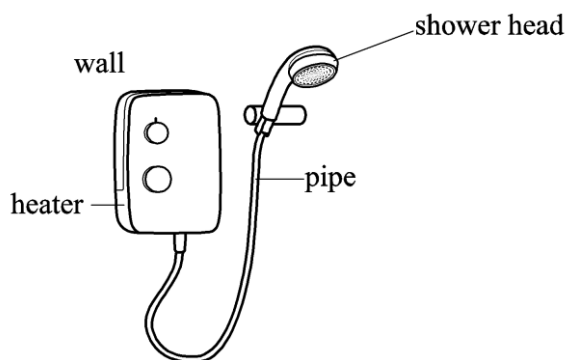

**Fig.1.1**

- (a) Water moves at constant speed through a pipe of cross-sectional area  $7.5 \times 10^{-5} \text{ m}^2$  to a shower head shown in **Fig. 1.1**. The maximum mass of water which flows per second is  $0.070 \text{ kg s}^{-1}$ .

- (i) Show that the maximum speed of the water in the pipe is about  $0.9 \text{ m s}^{-1}$ .

density of water =  $1000 \text{ kg m}^{-3}$

[2]

- (ii) The total cross-sectional area of the holes in the shower head is one quarter that of the pipe. Calculate the maximum speed of the water as it leaves the shower head.

maximum speed = .....  $\text{m s}^{-1}$  [1]

- (iii) Calculate the magnitude of the force caused by the accelerating water on the shower head.

force = ..... N [2]

- (iv) Draw on to **Fig. 1.1** the direction of the force in (iii). [1]

- (b) The water enters the heater at a temperature of 14 °C. At the maximum flow rate of 0.070 kg s<sup>-1</sup>, the water leaves the shower head at a temperature of 30 °C.

Calculate the rate at which energy is transferred to the water. Give a suitable unit for your answer.

specific heat capacity of water = 4200 J kg<sup>-1</sup> K<sup>-1</sup>

rate of energy transfer = .....unit ..... [3]

**Question 2 begins on page 5.**

SPECIMEN

**BLANK PAGE**

SPECIMEN

- 2 A motorcyclist riding on a level track is told to stop via a radio microphone in his helmet. The distance  $d$  travelled from this instant and the initial speed  $v$  are measured from a video recording.

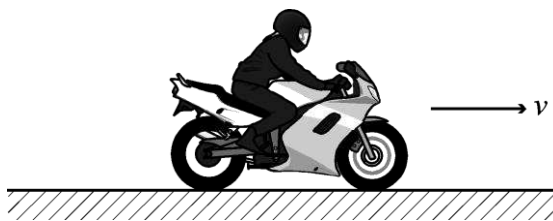

Fig. 2.1

A student is investigating how the stopping distance of a motorcycle with high-performance brakes varies with the initial speed.

- (a) Explain why the student predicts that  $v$  and  $d$  are related by the equation

$$d = \frac{v^2}{2a} + vt$$

where  $a$  is the magnitude of the deceleration of the motorcycle and  $t$  is the thinking time of the rider.

- (b) The student decides to plot a graph of  $\frac{d}{v}$  on the y-axis against  $v$  on the x-axis.  
Explain why this is a sensible decision.

.....

.....

..... [2]

(c) The measured values of  $v$  and  $d$  are given in the table.

$v / \text{m s}^{-1}$	$d / \text{m}$	$\frac{d}{v} / \text{s}$
$10 \pm 1$	$13.0 \pm 0.5$	
$15 \pm 1$	$24.5 \pm 0.5$	$1.63 \pm 0.14$
$20 \pm 1$	$39.5 \pm 0.5$	$1.98 \pm 0.12$
$25 \pm 1$	$57.5 \pm 0.5$	$2.30 \pm 0.11$
$30 \pm 1$	$79.0 \pm 0.5$	$2.63 \pm 0.10$
$35 \pm 1$	$103.0 \pm 0.5$	$2.94 \pm 0.09$

(i) Complete the missing value of  $\frac{d}{v}$  in the table, including the absolute uncertainties. Use the data to complete the graph of **Fig. 2.2**. Four of the points have been plotted for you.

[2]

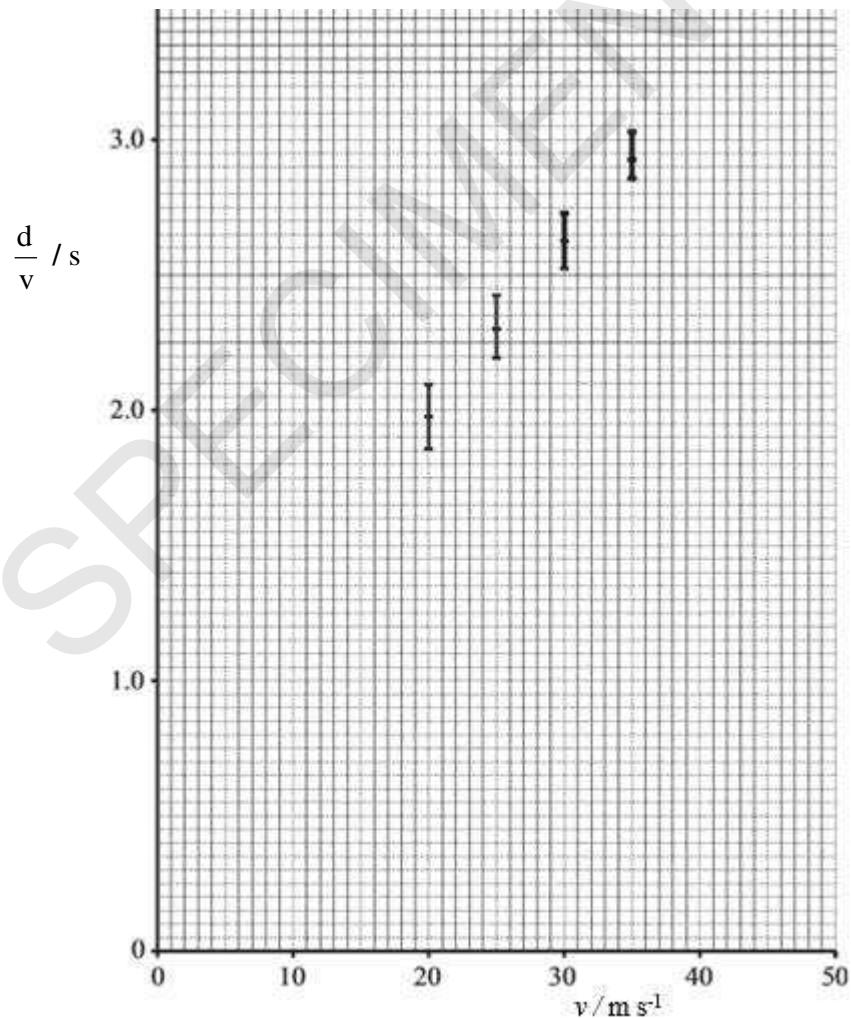

**Fig. 2.2**

- (ii) Use **Fig. 2.2** to determine the values of  $a$  and  $t$ , including their absolute uncertainties.

$$a = \dots \pm \dots \text{ m s}^{-2}$$

$$t = \dots \pm \dots \text{ s}$$

[4]

- (d) It was suspected that the method used to determine the distance  $d$  included a zero error. The distance recorded by the student was **larger** than it should have been.

Discuss how this would affect the actual value of  $t$  obtained in (c).

.....

.....

.....

.....

.....

.....

[3]

- 3 (a)** Some students are asked to use the laboratory 28 mm microwave transmitter **T** and receiver **R** apparatus to design a demonstration to illustrate the principle of a radar speed measuring device.

In **Fig. 3.1**, a movable hardboard sheet **H**, which is a partial reflector of microwaves, is placed in front of the metal sheet **M**, which is fixed.

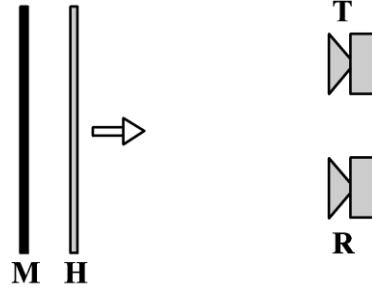

**Fig. 3.1**

The students expect the detected signal to change between maximum and minimum intensity when sheet **H** moves a distance of 7 mm towards the receiver.

When the detected signal is passed through an audio amplifier to a loudspeaker a sound should be heard. They claim that when the sheet moves at  $2.8 \text{ m s}^{-1}$  the frequency heard should be 200 Hz. You are to evaluate whether their experiment is feasible and whether their conclusions are correct.

- (i) Explain why the detected signal strength should vary and discuss what factors will determine whether the difference between maxima and minima can be detected.

.....

.....

.....

.....

.....

.....

.....

.....

.....

.....

.....

.....

.....

.....

.....

.....

.....

.....

.....

.....

.....

[6]



- (ii) Justify the students' predictions of 7 mm between maxima and minima and a sound at 200 Hz for a speed of  $2.8 \text{ m s}^{-1}$ .

.....

.....

.....

.....

.....

..... [3]

- (b) A police speed detector gun works by a different principle. Two short pulses of electromagnetic radiation, a time  $t_0$  apart, are 'fired' at the front of the vehicle which is moving directly towards the gun. The reflected pulses are received at a time  $t$  apart. A digital readout on the top of the gun displays the speed of the vehicle.

In the space below, by considering how far the vehicle moves in time  $t_0$ , show that the speed of the vehicle is given by the expression

$$v = \frac{c(t_0 - t)}{2t_0}$$

where  $c$  is the speed of light.

[3]

- 4 Civil engineers are designing a floating platform to be used at sea. **Fig. 4.1** shows a model for one section of this platform, a sealed metal tube of uniform cross-sectional area, loaded with small pieces of lead, floating upright in equilibrium in water.

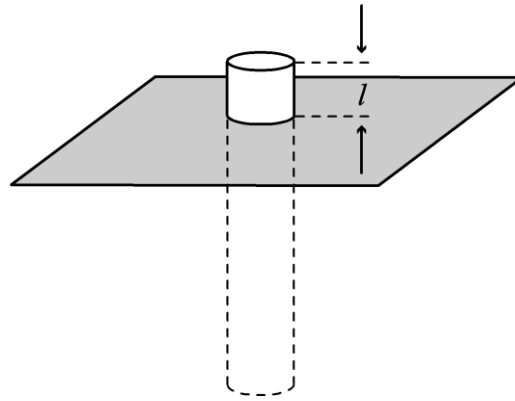

**Fig. 4.1**

- (a) The tube has length 300 mm and diameter 50 mm. The total mass of the lead and tube is 0.50 kg. Show that the length  $l$  of tube above the surface is more than 40 mm.

density of water =  $1000 \text{ kg m}^{-3}$

[3]

- (b) When the tube is pushed down a small amount into the water and released it moves vertically up and down with simple harmonic motion. The period of these oscillations which quickly die away is about one second.

The oscillations of the tube can be maintained over a range of low frequencies by using a flexible link to a simple harmonic oscillator.

**Fig. 4.2** shows a graph of amplitude of vertical oscillations of the tube against frequency obtained from this experiment.

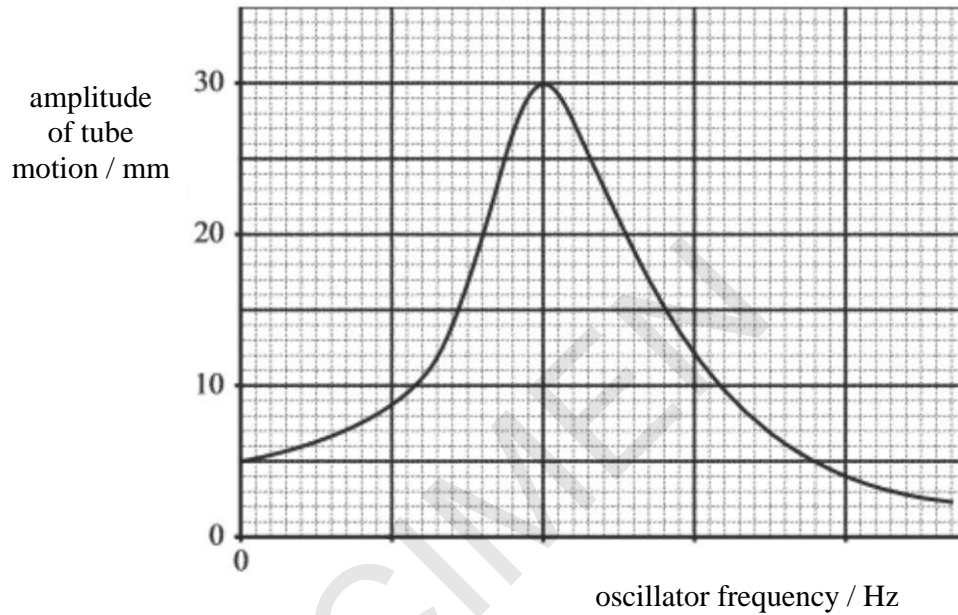

**Fig. 4.2**

- (i) Use information from **Fig. 4.2** to state the amplitude of the motion of the oscillator.

amplitude = ..... mm [1]

- (ii) Add a suitable scale to the frequency axis of **Fig. 4.2**. [1]

- (iii) The experiment is repeated in a much more viscous liquid such as motor oil. On **Fig. 4.2** sketch the graph that you would predict from this experiment. [2]

5 (a)\* **Fig. 5.1** shows a simple a.c. generator being tested by electrical engineers.

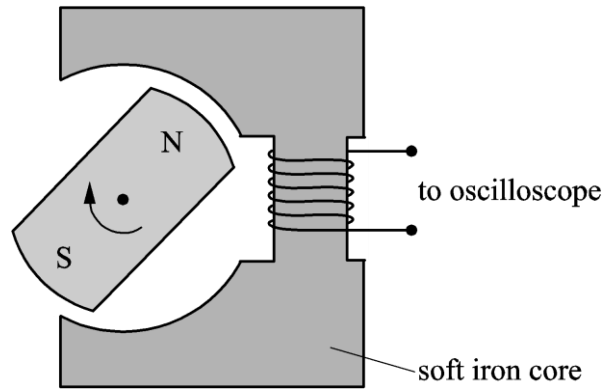

**Fig. 5.1**

It consists of a magnet, on the shaft of a **variable speed** motor, being rotated inside a cavity in a soft iron core. The output from the coil, wound on the iron core, is connected to an oscilloscope. The grid of **Fig. 5.2** shows a typical output voltage which would be displayed on the oscilloscope screen.

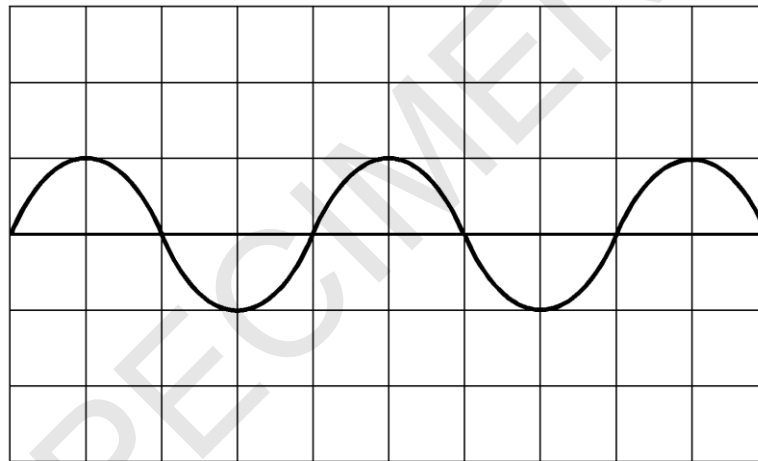

**Fig. 5.2**

According to Faraday’s law the e.m.f. induced is directly proportional to the rate of change of flux linkage. In the context of this experiment, the maximum e.m.f. induced is directly proportional to the frequency of rotation of the magnet.

Use the apparatus above to plan an experiment to validate Faraday’s law of electromagnetic induction. In your description include how the data is collected and analysed.

[6]

.....

.....

.....

.....

.....

.....

.....

.....

.....

.....

.....

.....

.....

.....

.....

.....

.....

.....

.....

.....

.....

.....

.....

.....

.....

.....

.....

Additional answer space if required.

.....

.....

.....

.....

.....

.....

.....

.....

.....

.....

.....

.....

.....

.....

.....

.....

.....

.....

.....

.....

.....

.....

SPECIMEN

- (b) **Fig. 5.3** shows the poles of a powerful electromagnet producing a uniform field in the gap between them. The dimension of each pole is 0.10 m by 0.080 m. There is no field outside the gap. A circular coil of 80 turns is placed so that it encloses the total flux of the magnetic field.

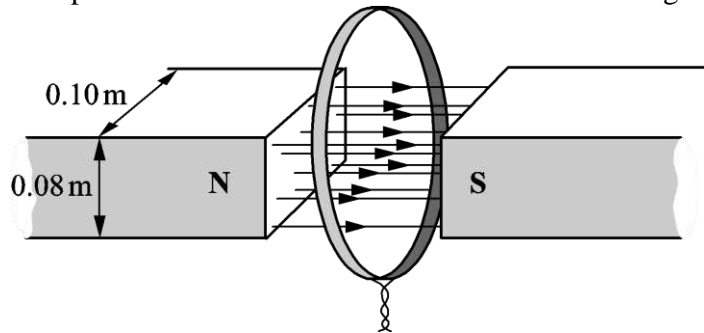

**Fig. 5.3**

- (i) The current in the electromagnet is reduced so that the field falls linearly from 0.20 T to zero in 5.0 s.

Calculate the initial flux in the gap and hence the e.m.f. generated in the coil during this time.

induced e.m.f. = ..... V [2]

- (ii) The coil is part of a circuit of total resistance R so that a current is generated in the circuit while the field is collapsing.

Draw on the coil in **Fig. 5.3** the direction of this induced current.

State how you applied the laws of electromagnetic induction to deduce the direction of this current.

.....  
 .....  
 ..... [2]

**BLANK PAGE**

**Question 6 begins on page 16**

SPECIMEN

- 6 An astronomer uses a spectrometer and diffraction grating to view a hydrogen emission spectrum from a star. The light is incident normally on the grating.

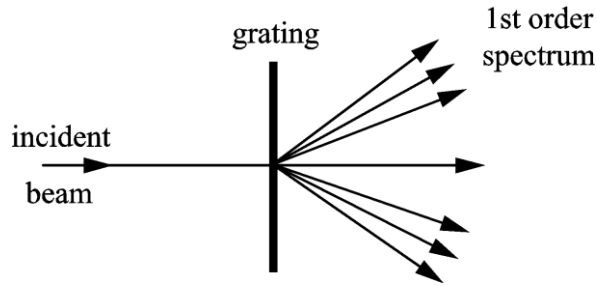

Fig. 6.1

- (a) First order diffraction maxima are observed at angles of  $12.5^\circ$ ,  $14.0^\circ$  and  $19.0^\circ$  to the direction of the incident light as shown in Fig. 6.1.  
Two of the wavelengths are  $4.33 \times 10^{-7}$  m and  $4.84 \times 10^{-7}$  m.  
Calculate the wavelength of the third line.

wavelength = ..... m [2]

- (b) In order to increase the accuracy of the values for wavelength, the student decides to look for higher order diffraction maxima.

- (i) State how this increases the accuracy.

.....  
..... [1]

- (ii) Calculate how many orders  $n$  can be observed for the shorter wavelength given in (a).

$n = \dots\dots\dots$  [2]



- (c) These three emission lines all arise from transitions to the same final energy level. The part of the energy level diagram of hydrogen relevant to these transitions is shown in **Fig. 6.2**.

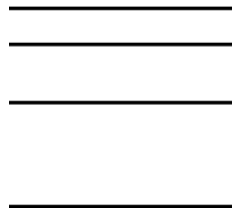

**Fig. 6.2**

- (i) Draw lines between the energy levels to indicate the transitions which cause the three emission lines and label them with their wavelengths. [1]
- (ii) There are other possible transitions between the energy levels shown in **Fig. 6.2**. The least energetic of these produces photons of  $4.8 \times 10^{-20}$  J.

Calculate the wavelength of these photons.

State in which region of the electromagnetic spectrum this wavelength is found.

wavelength .....m

region: ..... [3]



.....

.....

.....

.....

SPECIMEN

(b) Uranium-235 is used in many fission reactors as fuel and fusion reactors are still at an experimental stage.

(i) State one major disadvantage of having fission reactors.

.....  
.....[1]

(ii) The fission of a uranium-235 nucleus releases about 200 MeV of energy, whereas the fusion of four hydrogen-1 nuclei releases about 28 MeV.

At first sight it would appear that fusion would produce less energy than fission. However the energy released in the fission of one kilogramme of uranium-235 is about eight times less than the energy released in the fusion of one kilogramme of hydrogen-1.

Explain this by considering the initial number of particles in one kilogramme of each.

.....  
.....  
.....  
.....  
.....  
.....  
.....  
.....  
.....  
.....

[4]

**END OF QUESTION PAPER**

---

Copyright Information:

OCR is committed to seeking permission to reproduce all third-party content that it uses in the assessment materials. OCR has attempted to identify and contact all copyright holders whose work is used in this paper. To avoid the issue of disclosure of answer-related information to candidates, all copyright acknowledgements are reproduced in the OCR Copyright Acknowledgements booklet. This is produced for each series of examinations and is freely available to download from our public website ([www.ocr.org.uk](http://www.ocr.org.uk)) after the live examination series.

If OCR has unwittingly failed to correctly acknowledge or clear any third-party content in this assessment material, OCR will be happy to correct its mistake at the earliest possible opportunity.

For queries or further information please contact the Copyright Team, First Floor, 9 Hills Road, Cambridge CB2 1GE.

OCR is part of the Cambridge Assessment Group; Cambridge Assessment is the brand name of University of Cambridge Local Examinations Syndicate (UCLES), which is itself a department of the University of Cambridge.