

## Thursday 9 June 2022 – Afternoon

### GCSE (9–1) Physics B (Twenty First Century Science)

#### J259/01 Breadth in physics (Foundation Tier)

Time allowed: 1 hour 45 minutes

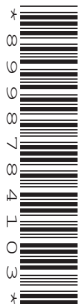

**You must have:**

- a ruler (cm/mm)
- the Data Sheet for GCSE (9–1) Physics B (inside this document)

**You can use:**

- a scientific or graphical calculator
- an HB pencil



Please write clearly in black ink. **Do not write in the barcodes.**

Centre number

--	--	--	--	--

Candidate number

--	--	--	--

First name(s)

---

Last name

---

### INSTRUCTIONS

- Use black ink. You can use an HB pencil, but only for graphs and diagrams.
- Write your answer to each question in the space provided. If you need extra space use the lined pages at the end of this booklet. The question numbers must be clearly shown.
- Answer **all** the questions.
- Where appropriate, your answers should be supported with working. Marks might be given for using a correct method, even if the answer is wrong.

### INFORMATION

- The total mark for this paper is **90**.
- The marks for each question are shown in brackets [ ].
- This document has **32** pages.

### ADVICE

- Read each question carefully before you start your answer.

Answer **all** the questions.

- 1 Layla uses a motor to lift a weight, as shown in the diagram. The motor is powered by a battery.

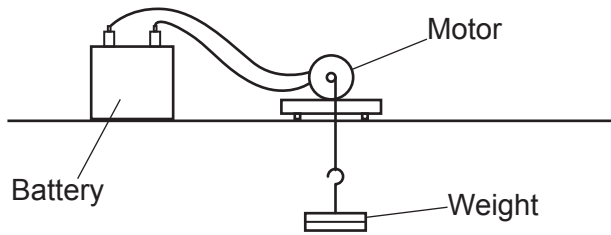

- (a) (i) What is the energy store of the battery?

Tick (✓) **one** box.

Chemical

Electrical

Nuclear

Thermal

[1]

- (ii) How is energy transferred from the battery to the motor?

Tick (✓) **one** box.

By heating

By radiation

Electrically

Mechanically

[1]

(b) (i) Layla measures the power of the motor as 13W.

It takes 3.0s to lift the weight.

Calculate the energy transferred by the motor.

Use the equation: energy transferred = power  $\times$  time

Energy = ..... J [2]

(ii) Layla repeats the experiment.

She measures the power three times in total.

Her three measurements are: 13W 17W 12W

Calculate the mean (average) power.

Mean power = ..... W [2]

(c) Layla's teacher says that the motor transfers too much energy to thermal energy.

How could Layla reduce this unwanted energy transfer?

Tick (✓) **one** box.

Use a higher voltage battery.

Use foam to insulate the motor.

Use longer wires.

Use oil to lubricate the motor.

[1]

2 Amir is studying the structure of atoms. **Fig. 2.1** shows a model of an atom.

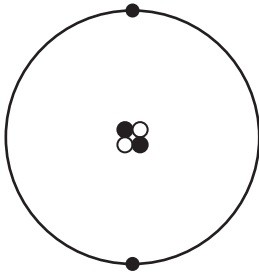

**Fig. 2.1**

(a) (i) Use a word from the list to complete the sentence.

**electrons          neutrons          protons**

The atom has a positive nucleus surrounded by negative ..... [1]

(ii) Use words from this list to complete the sentence.

**charge          mass          nucleus          space          volume**

Almost all of the ..... of the atom is in the ..... [2]

(b) What is the typical size of an atom?

Tick (✓) **one** box.

$10^{10}$  m

$10^5$  m

$10^{-5}$  m

$10^{-10}$  m

[1]

- (c) Amir researches the hydrogen atom. He finds diagrams of three different hydrogen atoms. The diagrams are shown in **Fig. 2.2**.

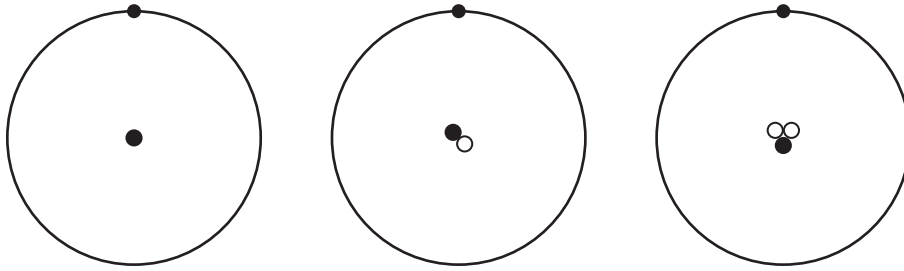

**Fig. 2.2**

**Amir**

They have the same number of protons, but a different number of neutrons.



- (i) Which statement could be used to describe these atoms?

Tick (✓) **one** box.

They are identical

They are isotopes

They are negative ions

They are positive ions

[1]

- (ii) One of the atoms is unstable.

Which statement can be used to describe this atom?

Tick (✓) **one** box.

The neutrons are positively charged.

The nucleus may emit a radioactive particle.

The proton orbits the nucleus.

There are electrons in the nucleus.

[1]

3 Beth investigates the pressure and volume of gases.

She uses the equipment shown in the diagram.

The pressure of the gas is increased by using a greater weight of books.

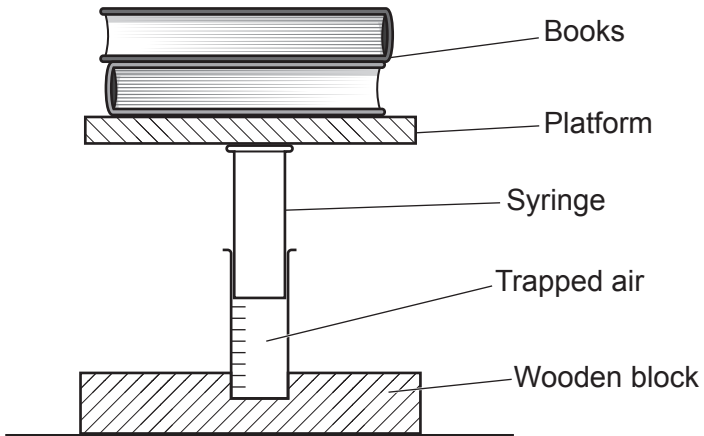

(a) The pressure of the gas causes forces against the inside surface of the syringe.

Which statement correctly describes the direction of these forces?

Tick (✓) **one** box.

They act at right angles to the surface of the syringe.

They all act downwards.

They act in random directions.

They act parallel to the surface of the syringe.

[1]

(b) Beth wants to increase the force from the books by 24 N.

(i) Calculate the mass of a book with a weight of 24 N.

Gravitational field strength = 10 N/kg

Use the equation: mass = weight  $\div$  gravitational field strength

Mass = ..... kg [2]

(ii) The surface area of the top of the syringe is 0.0012 m<sup>2</sup>.

Beth adds a book with a weight of 24 N.

Calculate the increase in pressure.

Use the equation: pressure = force normal to a surface  $\div$  area of that surface

Pressure = ..... Pa [2]

(c) The temperature of the gas remains constant.

Beth observes that as the pressure increases, volume decreases.

Which statements correctly explain why this happens?

Tick (✓) **two** boxes.

The particles are closer together.

The particles become smaller.

The particles collide more often.

The particles move faster.

The particles push with a larger force when they collide.

[2]

4 Kai investigates how the strength of a magnet depends on distance from the magnet.

He uses the equipment shown in the diagram. The distance between the magnet and the paperclips is varied by using different numbers of sheets of paper.

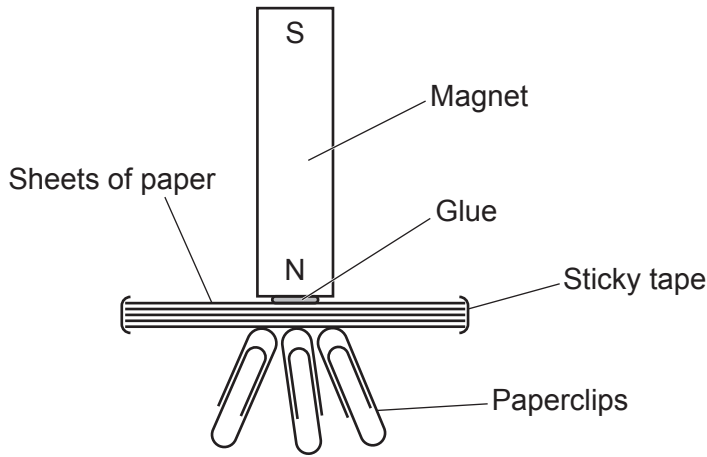

(a) (i) Complete the following sentences about the paperclips.

Use words from the list.

**copper    hard    induced    iron    permanent    zinc**

When the magnet is close to the paperclips they become ..... magnets.

They must be made of a magnetic material, such as .....

[2]

(ii) Describe the difference between a permanent and an induced magnet.

.....  
 .....

[1]

(b) Kai's results are shown in the table.

Number of sheets of paper	Number of paperclips attracted to magnet			
	1	2	3	Mean
1	9	6	10	8.3
2	5	7	11	7.7
3	5	5	8	6.0
4	3	4	7	4.7
5	3	6	2	3.7
6	2	5	3	3.3



(i) Kai evaluates the quality of his data in the table.

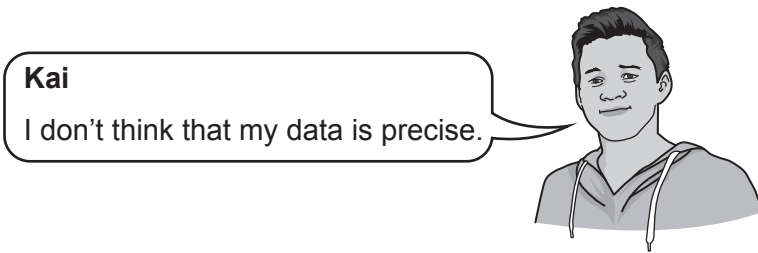

Explain why Kai is correct.

.....  
.....  
..... [1]

(ii) Describe the pattern in Kai's data.

.....  
.....  
..... [1]

(c) Kai decides to investigate the strength of electromagnets.

He builds an electromagnet by wrapping a coil of wire around an iron core.

How could Kai increase the strength of his electromagnet?

Tick (✓) **one** box.

Swap the iron core for a plastic core.

Increase the current in the wires.

Increase the resistance of the wires.

Increase the spacing between the coils.

[1]

5 Eve investigates how white light reflects from a mirror.

Fig. 5.1 shows her equipment.

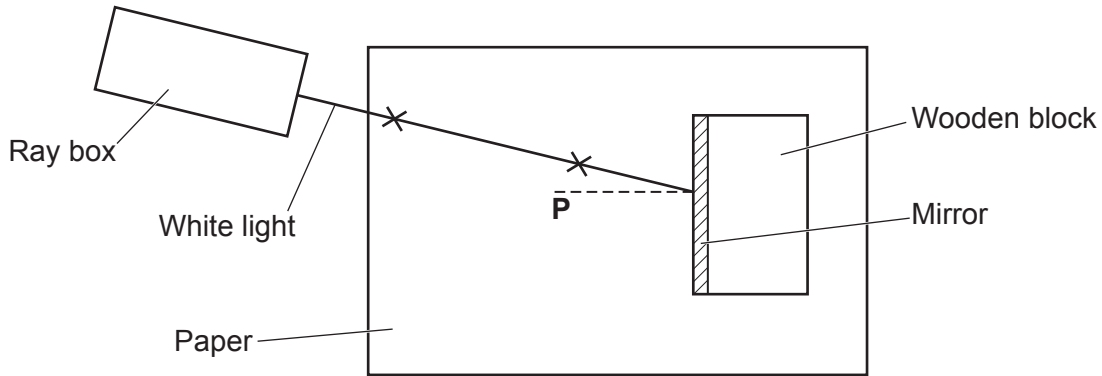

Fig. 5.1

(a) What is the name of the dotted line **P** in Fig. 5.1?

Tick (✓) **one** box.

Boundary line

Incident ray

Normal line

Reflected ray

[1]

(b) Eve records the position of the ray by marking crosses on the paper and then joining them together.

Describe two things that Eve should do to record the position as accurately as possible.

1 .....

.....

2 .....

.....

[2]

(c) Fig. 5.2 shows the expected result from Eve's investigation.

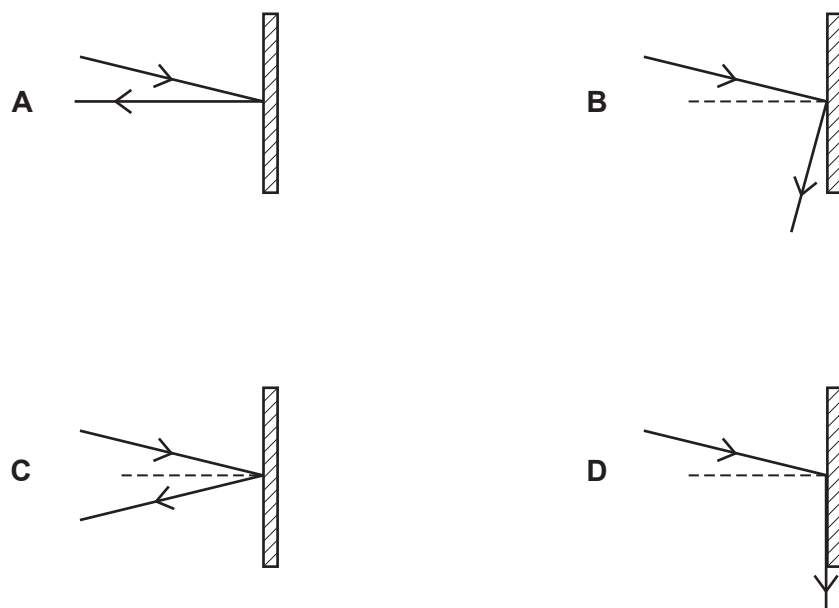

Fig. 5.2

Write the letter (A, B, C or D) of the correct diagram.

..... [1]

(d) Eve wants to extend her experiment.

**Eve**

White light is a mixture of different wavelengths.  
I want to investigate the reflection of just one wavelength of light.



Suggest how Eve could extend her experiment to investigate just one wavelength of light.

.....

.....

.....

..... [2]

6 Ben uses a battery-powered shaver.

The shaver uses an electric motor to move the blades.

A circuit diagram for the shaver is shown below.

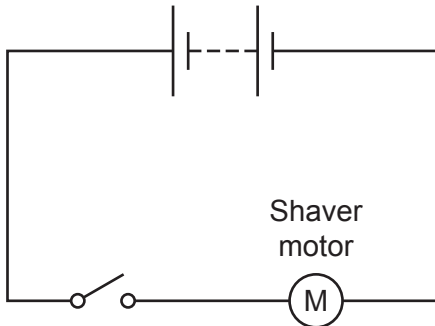

(a) When the shaver is switched on, energy is transferred.

Which **two** statements correctly describe changes in the energy stores when the shaver is switched on?

Tick (✓) **two** boxes.

Chemical energy store in battery decreases.

Elastic energy store in room increases.

Gravitational energy store in battery decreases.

Kinetic energy store in battery decreases.

Nuclear energy store in room increases.

Thermal energy store in room increases.

[2]

(b) The potential difference of the battery is 1.2V.

(i) Each time Ben uses the shaver, 180C of charge flows.

Calculate the energy transferred each time he uses the shaver.

Use the equation: energy transferred = charge flow  $\times$  potential difference

Energy transferred = ..... J [2]

(ii) The power of the shaver is 1.1 W.

Calculate the current flowing through the shaver.

Use the equation: power = potential difference  $\times$  current

Give your answer to **2** significant figures.

Current = ..... A [3]

7 Fig. 7.1 shows a hole puncher.

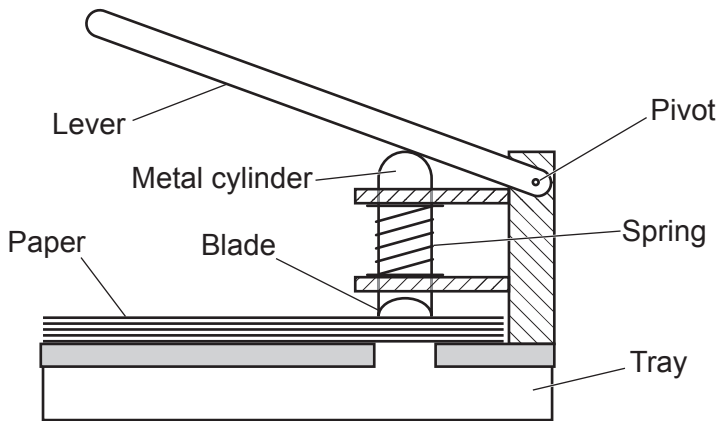

Fig. 7.1

The lever is pushed down to punch a hole in some paper.

Fig. 7.2 shows two of the forces on the lever when it has been pushed down. The force arrows **P** and **Q** have not been drawn to scale.

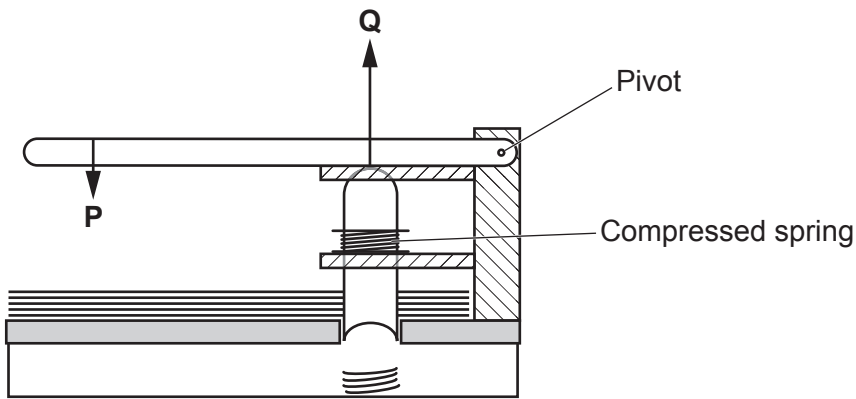

Fig. 7.2

(a) The size of force **P** is 30 N.

The distance from the pivot to force **P** is 6.0 cm.

Calculate the moment of the force.

Use the equation: moment of a force = force  $\times$  distance (normal to direction of the force)

Moment = ..... Nm [3]

(b) (i) The force **Q** is caused by the metal cylinder pushing against the lever.

Which statement describes how to increase **Q** without increasing **P**?

Tick (✓) **one** box.

- Push closer to the pivot.
- Push further from the pivot.
- Push sideways instead of down.
- Push up instead of down.

[1]

(ii) The lever exerts a force **R** on the metal cylinder. The force **R** and force **Q** are an interaction pair.

Compare and contrast force **P** to the force **Q**.

.....  
..... [2]

(c) Explain how the lever returns to its original position when **P** is removed.

.....  
.....  
..... [1]

8 Jack is a sprinter. He uses a parachute when he trains, as shown in **Fig. 8.1**.

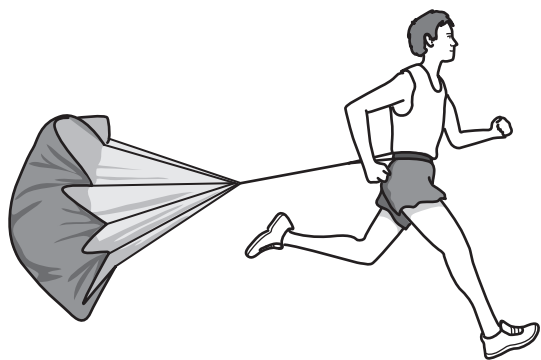

**Fig. 8.1**

(a) **Fig. 8.2** shows the forces acting on Jack when he is training.

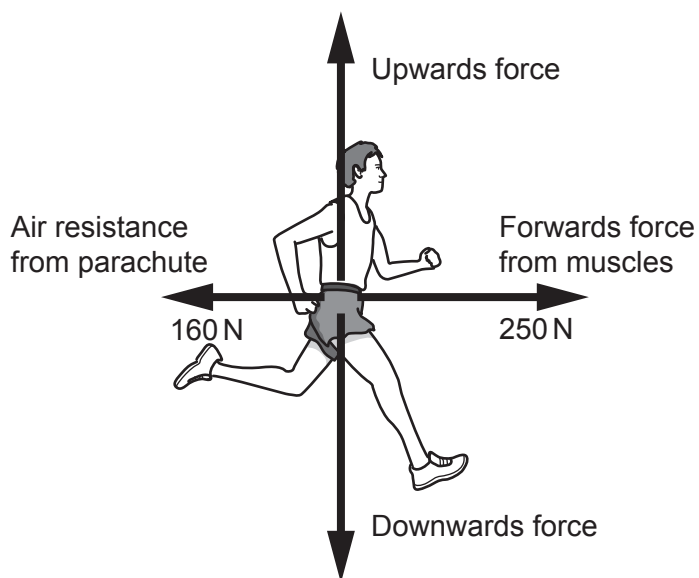

**Fig. 8.2**

(i) Name the upwards and downwards forces acting on Jack.

Upwards force .....

Downwards force .....

[2]

(ii) Jack's mass is 60 kg.

Calculate Jack's acceleration.

Use information from **Fig. 8.2**.

Use the equation: acceleration = force ÷ mass

Acceleration = ..... m/s<sup>2</sup> [3]



(b) Fig. 8.3 shows the horizontal forces acting on Jack a few moments later. Jack is still running.

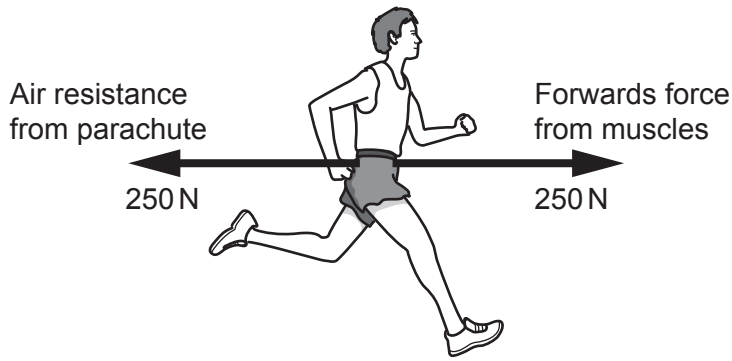

**Fig. 8.3**

Describe Jack's velocity, and explain your answer using information from Fig. 8.3.

.....

.....

.....

..... [2]

(c) Jack wants to buy a new training parachute. He wants a parachute that will give the biggest possible air resistance.

The table shows information about three parachutes.

Parachute	Diameter (cm)	Mass (kg)	Cost
A	42	0.32	£9
B	48	0.29	£15
C	56	0.30	£12

Suggest which parachute Jack should buy.

.....

.....

..... [2]

9 Jane investigates how the resistance of a wire depends on its diameter.

She uses the circuit shown in the diagram to measure the resistance of wires of different diameters.

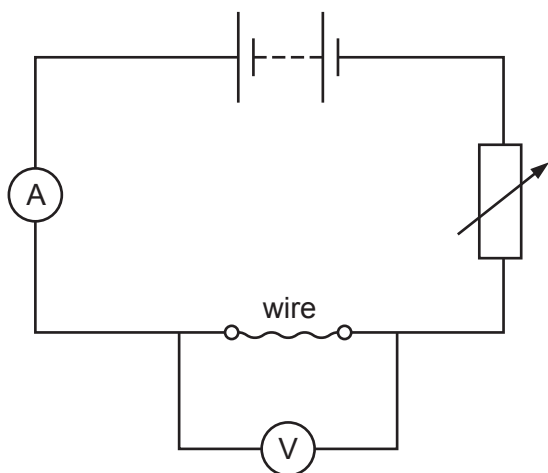

(a) One control variable in this experiment is the temperature of the wire.

(i) Suggest how to keep the temperature of the wire constant.

.....  
 ..... [1]

(ii) State **two** other control variables for this experiment.

1 .....  
 .....  
 2 .....  
 ..... [2]

(b) Jane makes the following measurements for one wire.

reading on voltmeter = 0.55 V

reading on ammeter = 2.5 A

Use the Data Sheet.

Calculate the resistance of the wire.

Resistance = ..... Ω [3]

(c) The table and graph show Jane's results.

diameter (mm)	resistance ( $\Omega$ )
0.19	0.57
0.23	0.39
0.27	0.28
0.32	0.22
0.38	0.15
0.46	0.10

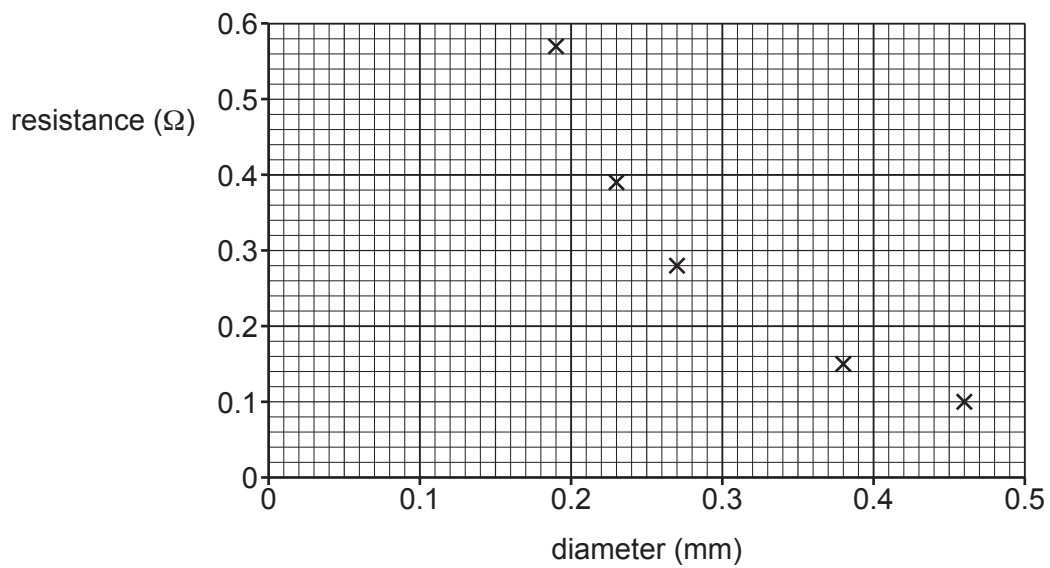

(i) Complete the graph by plotting the missing result from the table and draw a line of best fit. [2]

(ii) Write a conclusion for Jane's investigation.

.....

.....

.....

..... [2]

10 Different types of wave can be used for communications.

Fifty years ago, microwaves were used for long distance communications. Microwaves travel through the air between microwave aerials.

Now, light waves travelling along optical fibres are normally used instead.

(a) State **one** similarity and **one** difference between microwaves and light waves.

Similarity .....

.....

Difference .....

.....

[2]

(b) The table compares the speed of the two methods of communication.

	Method of communication	Speed of wave (m/s)
1	Microwaves in air	$3.0 \times 10^8$
2	Light waves in an optical fibre	$2.0 \times 10^8$

(i) The distance between two locations is 90 km.

Use the Data Sheet.

Calculate the time taken for a light wave to travel this distance through an optical fibre.

Time = ..... s [4]

(ii) Li thinks about which method is better.

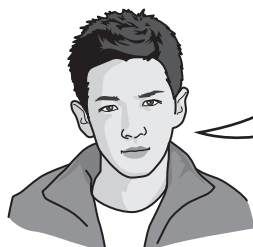

**Li**

Microwaves are better because the signals travel faster through the air.

Evaluate Li's statement.

.....  
 ..... [1]

22  
BLANK PAGE

PLEASE DO NOT WRITE ON THIS PAGE

- 11 Nina investigates how the resistance of a thermistor depends on its temperature.

She controls the temperature of the thermistor by placing it in a beaker of water at different temperatures.

Fig. 11.1 shows part of her circuit diagram.

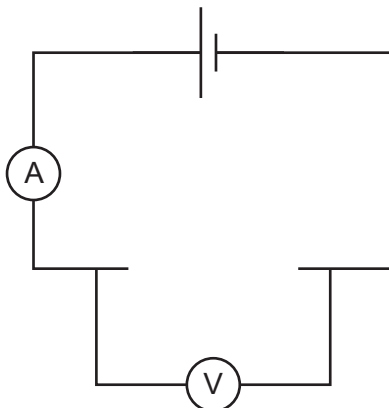

Fig. 11.1

- (a) Complete Fig. 11.1 to include a thermistor correctly connected to the circuit. [1]
- (b) Table 11.1 shows her data.

Temperature ( $^{\circ}\text{C}$ )	Resistance ( $\Omega$ )
0	1300
80	1800

Table 11.1

**Nina**

My hypothesis is that as temperature increases, resistance increases.

To test this, I need a measurement at a temperature of about  $50^{\circ}\text{C}$ .



- (i) Suggest how she could make water with a temperature of about  $50^{\circ}\text{C}$ .

.....  
 ..... [1]

(ii) **Table 11.2** shows her data including the measurement at 50 °C.

Temperature (°C)	Resistance ( $\Omega$ )
0	1300
50	350
80	1800

**Table 11.2**

How will the new data affect Nina's confidence in her hypothesis?

Explain your answer.

Tick (✓) **one** box.

Less confident

More confident

No effect

Explanation: .....

.....

..... [2]



(c) Nina made 7 more measurements at different temperatures.

All her data is plotted in **Fig. 11.2**.

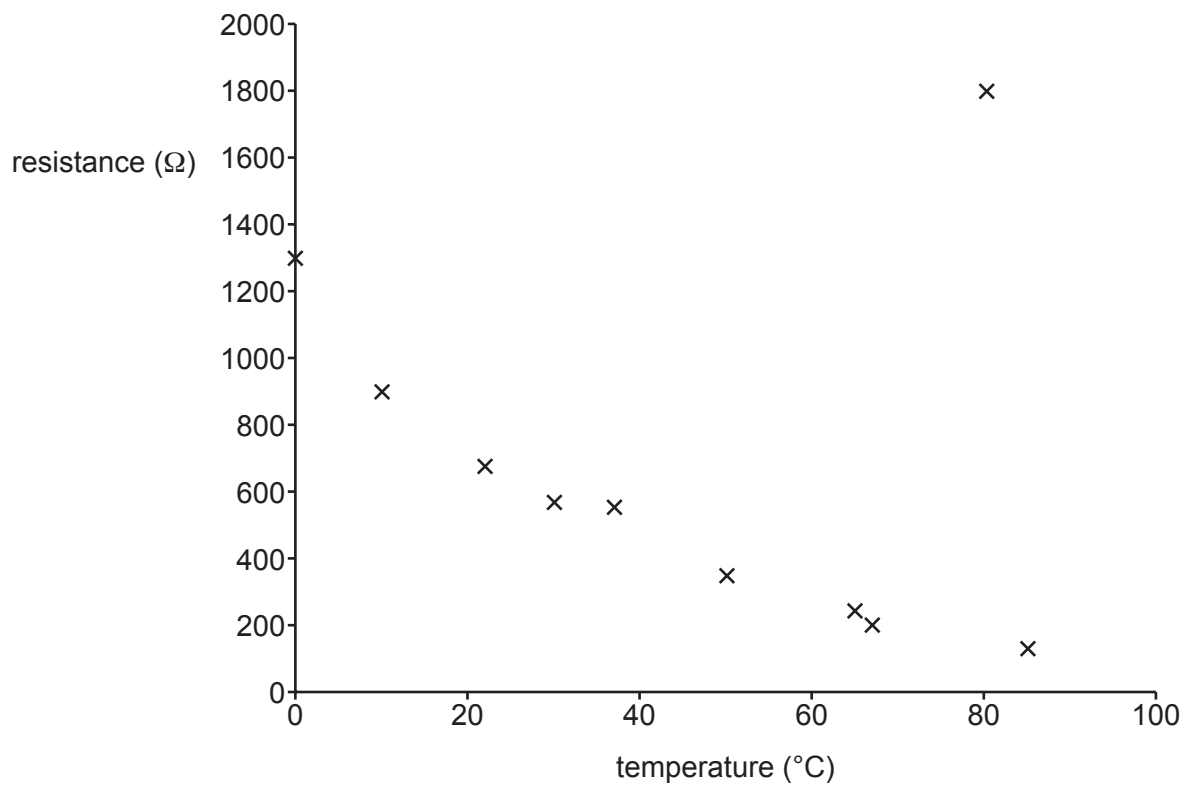

**Fig. 11.2**

Describe the trend shown in **Fig. 11.2**.

.....

.....

.....

..... [2]

12 Jamal, Sara and Jack are playing rounders.

Rounders is a game played with a bat and ball. **Fig. 12.1** shows the layout of the pitch. The bowler stands at X and throws the ball towards the batter at Y.

The batter hits the ball and then tries to run to third base, from Y to Z.

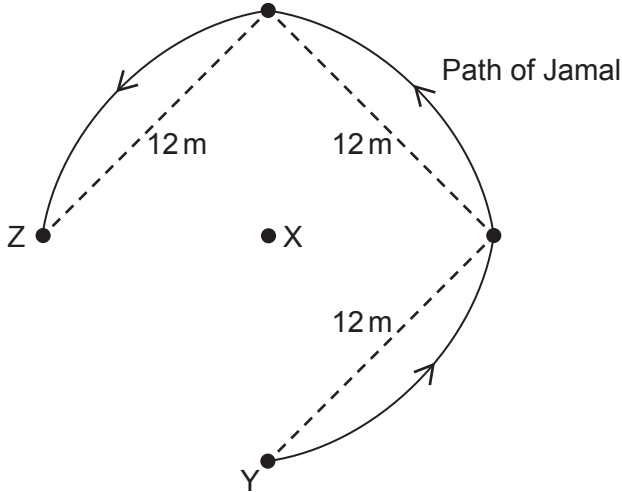

**Fig. 12.1**

(a) Jamal hits the ball and runs along the path from Y to Z shown in **Fig. 12.1**.

**Sara**

The distance travelled by Jamal is different to his displacement.



Explain why Sara is correct. Use information from **Fig. 12.1** in your answer.

.....

.....

.....

..... [2]

(b) Sara and Jack try to estimate how quickly Jamal speeded up.

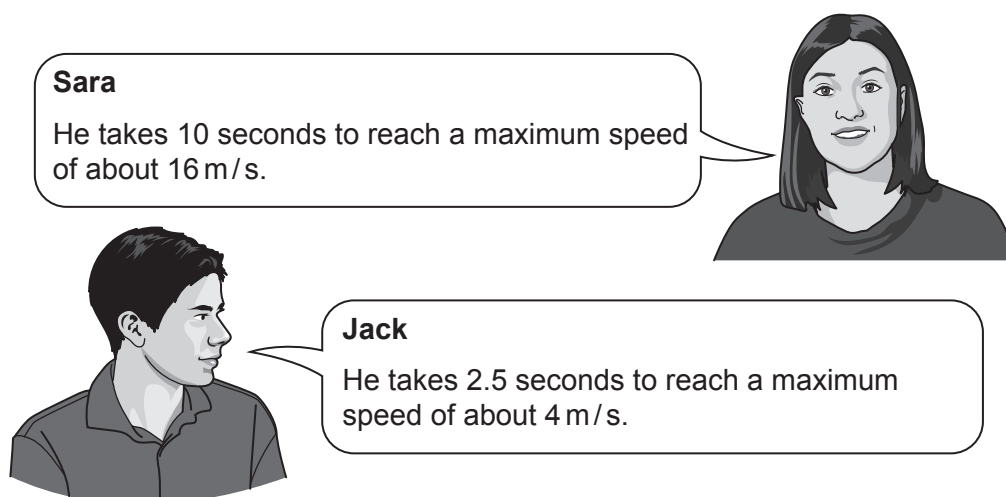

**Sara**  
He takes 10 seconds to reach a maximum speed of about 16 m/s.

**Jack**  
He takes 2.5 seconds to reach a maximum speed of about 4 m/s.

(i) Which is the better estimate? Explain your answer.

Tick (✓) **one** box.

Sara

Jack

.....  
..... [1]

(ii) Use **either** estimate to calculate Jamal's acceleration.

Use the Data Sheet.

Acceleration = ..... m/s<sup>2</sup> [3]

13 Cancer can be treated using radiation. This is called radiotherapy.

The diagram shows one way to use gamma rays to treat cancer.

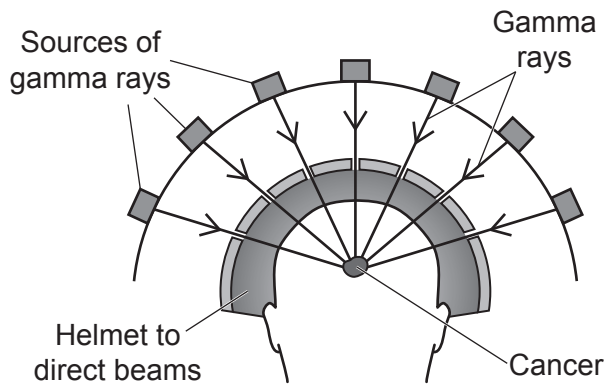

(a) Describe why gamma rays can be used to treat cancer using the method shown in the diagram.

.....

.....

.....

.....

.....

.....

.....

.....

.....

.....

.....

[3]

(b) Ben's cancer is treated using gamma rays.

**Ben**  
After the radiotherapy I will be contaminated with radiation.



Explain why Ben is wrong.

.....  
.....  
..... [2]

(c) X-rays can also be used for radiotherapy.

X-rays are produced electrically using a machine.

Suggest an advantage of treating cancer using X-rays instead of gamma rays.

.....  
.....  
..... [1]

**END OF QUESTION PAPER**

**ADDITIONAL ANSWER SPACE**

If additional space is required, you should use the following lined page(s). The question number(s) must be clearly shown in the margin(s).

This section of the page is a large, empty area of lined paper. It features a vertical solid line on the left side, creating a margin. The rest of the page is filled with horizontal dotted lines, providing space for writing answers. The lines are evenly spaced and extend across the width of the page.

Handwriting practice lines consisting of a solid vertical line on the left and horizontal dotted lines extending across the page.

A large area of the page is filled with horizontal dotted lines, providing a space for writing answers. A solid vertical line runs down the left side of this area, creating a margin.



Oxford Cambridge and RSA

**Copyright Information**

OCR is committed to seeking permission to reproduce all third-party content that it uses in its assessment materials. OCR has attempted to identify and contact all copyright holders whose work is used in this paper. To avoid the issue of disclosure of answer-related information to candidates, all copyright acknowledgements are reproduced in the OCR Copyright Acknowledgements Booklet. This is produced for each series of examinations and is freely available to download from our public website ([www.ocr.org.uk](http://www.ocr.org.uk)) after the live examination series. If OCR has unwittingly failed to correctly acknowledge or clear any third-party content in this assessment material, OCR will be happy to correct its mistake at the earliest possible opportunity.

For queries or further information please contact The OCR Copyright Team, The Triangle Building, Shaftesbury Road, Cambridge CB2 8EA.

OCR is part of Cambridge University Press & Assessment, which is itself a department of the University of Cambridge.