

Write your name here

Surname

Other names

Pearson Edexcel
Level 3 GCE

Centre Number

--	--	--	--	--	--

Candidate Number

--	--	--	--	--	--

Physics

Advanced

**Paper 3: General and Practical Principles
in Physics**

Thursday 29 June 2017 – Morning
Time: 2 hour 30 minutes

Paper Reference

9PH0/03

You do not need any other materials.

Total Marks

Instructions

- Use **black** ink or ball-point pen.
- **Fill in the boxes** at the top of this page with your name, centre number and candidate number.
- Answer **all** questions.
- Answer the questions in the spaces provided – *there may be more space than you need.*

Information

- The total mark for this paper is 120.
- The marks for **each** question are shown in brackets – *use this as a guide as to how much time to spend on each question.*
- You may use a scientific calculator.
- In questions marked with an **asterisk** (*), marks will be awarded for your ability to structure your answer logically showing how the points that you make are related or follow on from each other where appropriate.

Advice

- Read each question carefully before you start to answer it.
- Try to answer every question.
- Check your answers if you have time at the end.
- You are advised to show your working in calculations including units where appropriate.

Turn over ►

P48995RRA

©2017 Pearson Education Ltd.

1/1/1/1/1/



Pearson

Answer ALL questions in the spaces provided.

1 A physics textbook states that “when carrying out experimental measurements there will always be errors and uncertainties”.

(a) Describe what physicists mean by error and by uncertainty.

(2)

.....

.....

.....

.....

.....

.....

(b) Give two reasons why a measurement may have an uncertainty.

(2)

.....

.....

.....

.....

.....

.....

(Total for Question 1 = 4 marks)

DO NOT WRITE IN THIS AREA

DO NOT WRITE IN THIS AREA

DO NOT WRITE IN THIS AREA



- 2 A student carries out measurements to determine the density of glass. The student has 20 glass microscope slides available.

The approximate dimensions of one slide are shown.

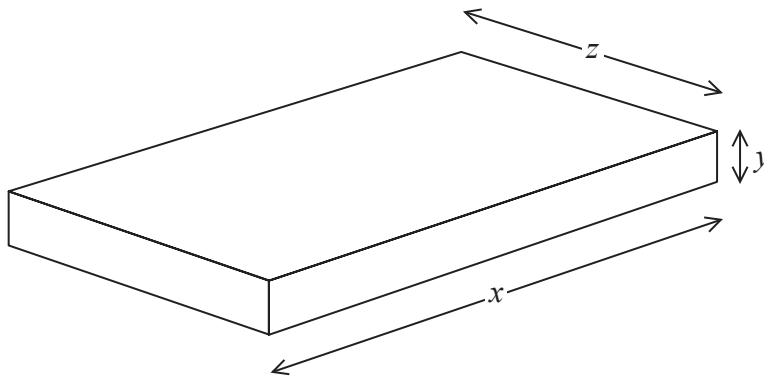

$$\begin{aligned}x &\approx 75 \text{ mm} \\y &\approx 1 \text{ mm} \\z &\approx 25 \text{ mm}\end{aligned}$$

- (a) The density is calculated using the equation

$$\text{density} = \frac{\text{mass}}{\text{volume}}$$

Describe how the student can determine an accurate value for the density of the glass. Your answer should include the measuring instruments required.

(4)

.....

.....

.....

.....

.....

.....

.....

.....

.....

.....

- (b) State one precaution that the student should take to ensure the measurements are accurate.

(1)

.....

.....

(Total for Question 2 = 5 marks)



3 In the 19th century experiments with magnetic and electric field deflections were used to determine the charge to mass ratio of electrons.
Later experiments showed the diffraction of electrons as they passed through thin metal foils.
Deduce what these experiments tell us about electrons.

(3)

.....

.....

.....

.....

.....

.....

.....

.....

.....

.....

.....

.....

.....

.....

.....

.....

.....

.....

.....

.....

.....

.....

(Total for Question 3 = 3 marks)

DO NOT WRITE IN THIS AREA

DO NOT WRITE IN THIS AREA

DO NOT WRITE IN THIS AREA



DO NOT WRITE IN THIS AREA

DO NOT WRITE IN THIS AREA

DO NOT WRITE IN THIS AREA

4 A student set up a “seconds pendulum”. This is a simple pendulum for which the time taken to move from the bob’s highest position on one side to its highest position on the opposite side is 1.00 s.

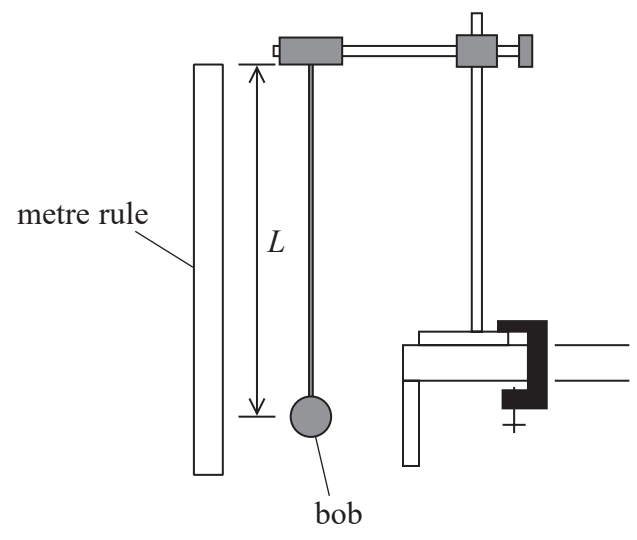

(a) Calculate the length L required for the pendulum to be a “seconds pendulum”. (2)

.....

.....

.....

.....

$L =$

(b) The student set the pendulum into oscillation. She used a stopwatch to check the accuracy of the pendulum’s period T .

Describe the procedure the student should have used to obtain an accurate value for T . (2)

.....

.....

.....

.....

.....

.....



- (c) Another student suggested that the uncertainty in the measurement of the time period of the pendulum could be reduced by using a light gate and a data logger. The data logger would record the time between successive interruptions of the light beam. Both the data logger and the stopwatch have a resolution of 0.01 s.

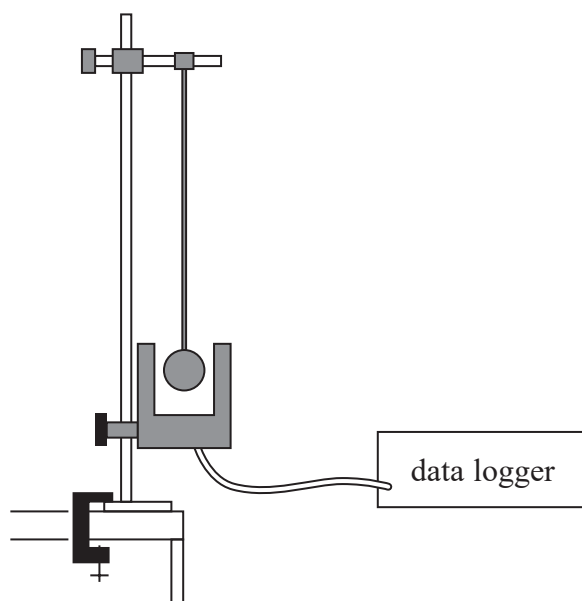

Comment on the student's suggestion of using a data logger rather than a stopwatch.

(4)

(Total for Question 4 = 8 marks)



*5 The following extract comes from a section on forces, on a website written for children.

Forces act in pairs.
The lift force on a plane pushing it up into the sky is paired with gravity, which pulls the plane back towards the centre of the Earth.



If both forces in the pair are equal, the plane will stay at rest in the same place.

Criticise this extract.

(6)

Area with horizontal dotted lines for writing the answer.

(Total for Question 5 = 6 marks)



6 A student carried out an experiment to determine the resistivity of nichrome wire. He used an ohmmeter to measure the resistance of a length of nichrome wire as shown.

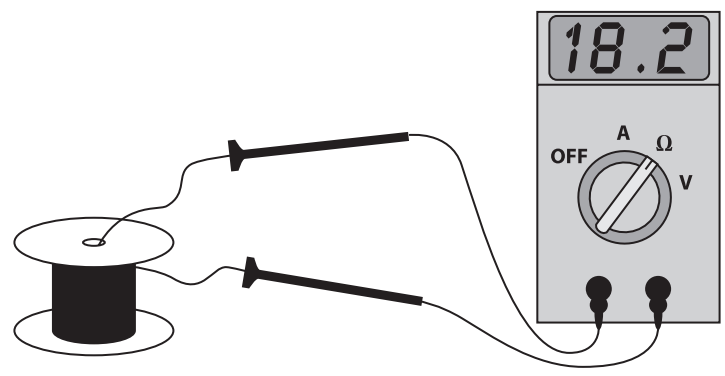

The diameter of the wire was measured as $0.27 \text{ mm} \pm 0.01 \text{ mm}$.
The length of the wire was measured as $1.25 \text{ m} \pm 0.05 \text{ m}$.

(a) Determine which of the three measurements introduces the greatest uncertainty into the value for the resistivity.
Your answer should include calculations.

(4)

.....

.....

.....

.....

.....

.....

.....

.....

.....

.....

.....

.....

.....

.....

.....

.....

.....

.....

.....

.....

.....

.....

.....



DO NOT WRITE IN THIS AREA

DO NOT WRITE IN THIS AREA

DO NOT WRITE IN THIS AREA

(b) Explain how the student could reduce the uncertainty in the measurement of the diameter. (2)

.....

.....

.....

.....

(c) Calculate the minimum value of resistivity possible from the student's data. (4)

.....

.....

.....

.....

.....

.....

.....

.....

Minimum resistivity =

(Total for Question 6 = 10 marks)



- 7 A teacher is demonstrating how to measure the speed of sound in a steel rod. The equipment comprises a hanging steel rod and a hammer connected to a data logger as shown.

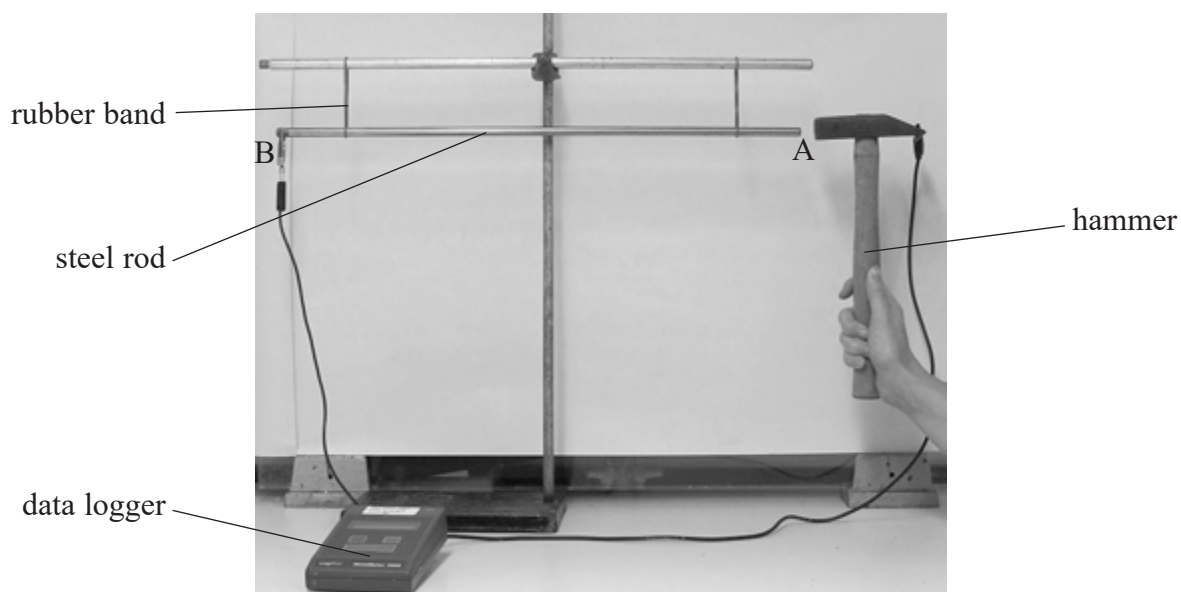

The rod is tapped at A with the hammer. A compression pulse travels to B and is reflected back. When the reflection reaches A the hammer loses contact with the rod. Whilst the hammer is in contact with the rod the output from a 5 V supply is recorded by the data logger.

The graph shows the output from the data logger for one hammer tap.

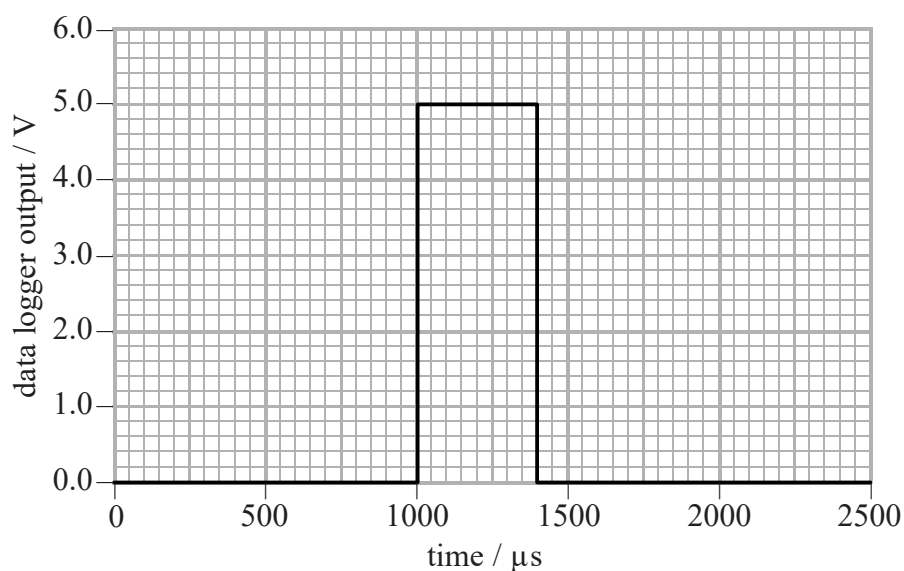

(a) Explain why a data logger is appropriate for this demonstration.

(2)

(b) (i) Use the graph to show that the speed of the pulse in the rod is about 6000 m s^{-1} .

length of steel rod = 1.18 m

(3)

(ii) The speed of sound v in the rod depends on the Young modulus E and the density ρ of the material of the rod as given by the equation

$$v = \sqrt{\frac{E}{\rho}}$$

Calculate the Young modulus of steel.

$$\rho_{\text{steel}} = 7850 \text{ kg m}^{-3}$$

(2)

Young modulus of steel =

(Total for Question 7 = 7 marks)



- 8 A student wanted to plot a graph of current against potential difference for a light emitting diode (LED). He used the circuit shown.

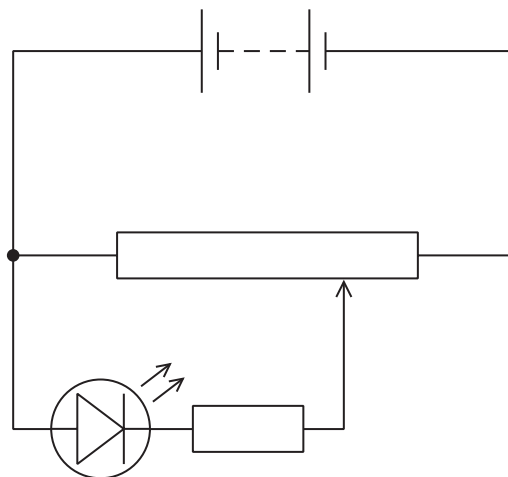

- (a) Add an ammeter and a voltmeter to the circuit diagram that would enable the data to be collected.

(1)

- (b) The graph of current against potential difference obtained by the student is shown.

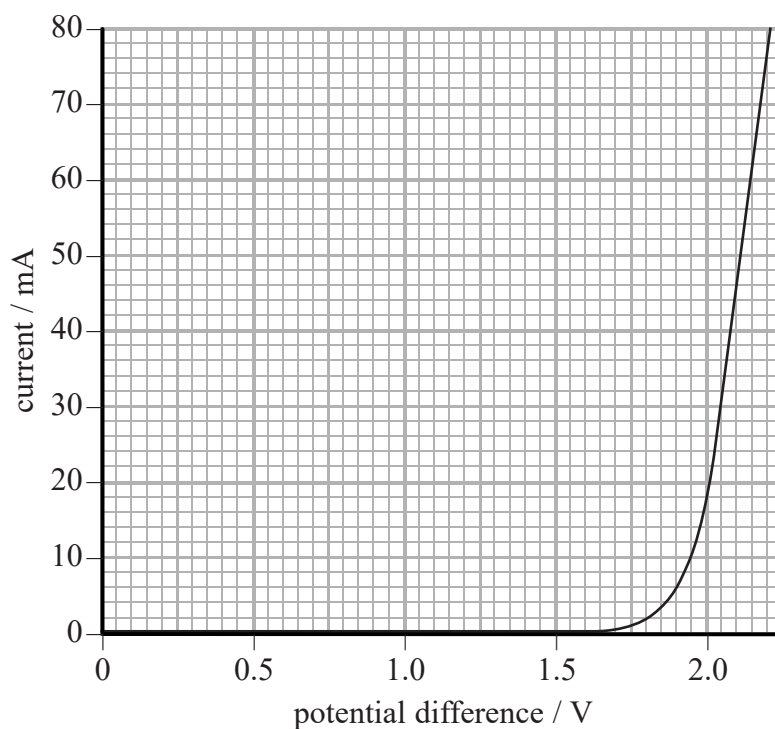

(i) The student wrote the following conclusion.

"The graph shows that in general the LED is not an ohmic conductor. However, for potential differences greater than +2 V, Ohm's law is obeyed since the graph is linear in this region."

Criticise the student's conclusion.

(2)

.....

.....

.....

.....

.....

.....

(ii) The student used the LED with a 5.0 V power supply as shown in the circuit.

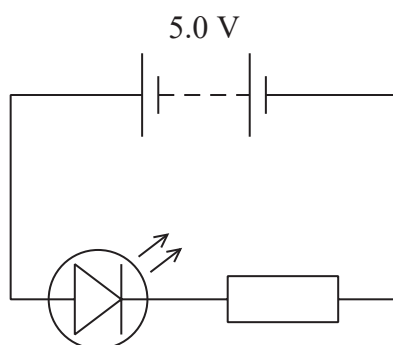

To be lit to normal brightness the current through the LED must be 18 mA.

Calculate the resistance of the resistor needed in the circuit.

(4)

.....

.....

.....

.....

.....

.....

Resistance =

(Total for Question 8 = 7 marks)

DO NOT WRITE IN THIS AREA

DO NOT WRITE IN THIS AREA

DO NOT WRITE IN THIS AREA



- 9 The majority of stars in the universe are thought to be main sequence stars. For such stars the luminosity increases with the mass of the star.

- (a) It is suggested that the relationship between luminosity and mass is of the form

$$L = L_{\text{Sun}} M^p$$

where L = luminosity, M = (mass of star / mass of the Sun) and L_{Sun} and p are constants.

Explain why a graph of $\log L$ against $\log M$ would give a straight line.

(2)

.....

.....

.....

.....

- (b) The table shows data for a range of main sequence stars.

$L/10^{25}\text{W}$	M		
3.63	0.557		
469	1.88		
5920	3.52		
40 800	5.85		
294 000	9.72		

- (i) Plot a graph of $\log L$ against $\log M$. You may use the columns provided to show any processed data.

(5)



DO NOT WRITE IN THIS AREA

DO NOT WRITE IN THIS AREA

DO NOT WRITE IN THIS AREA

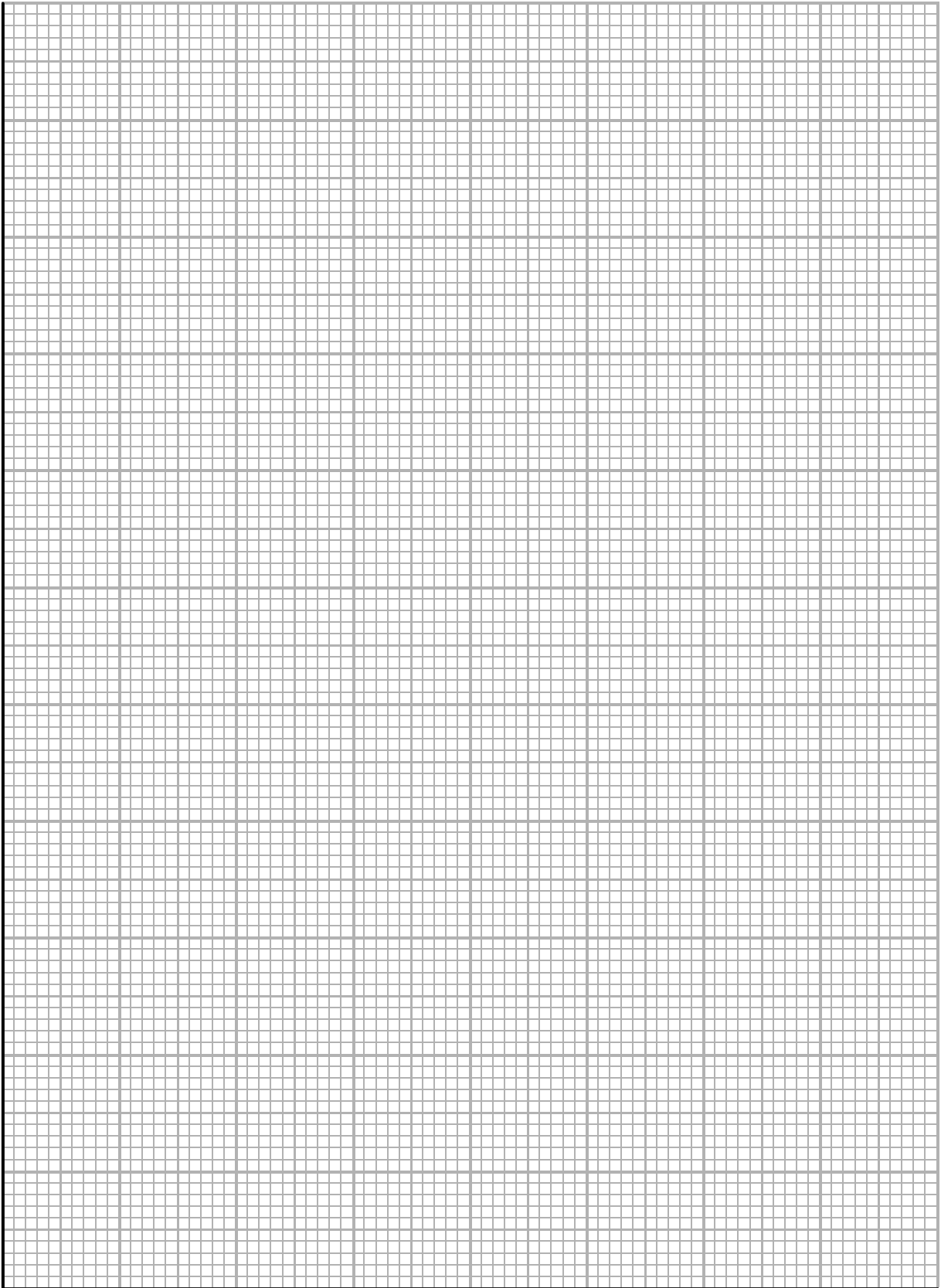

P 4 8 9 9 5 R R A 0 1 5 3 6

(ii) Determine values for p and L_{Sun} and hence state the mathematical relationship between L and M .

(4)

.....

.....

.....

.....

.....

.....

.....

.....

.....

(Total for Question 9 = 11 marks)

DO NOT WRITE IN THIS AREA

DO NOT WRITE IN THIS AREA

DO NOT WRITE IN THIS AREA



DO NOT WRITE IN THIS AREA

DO NOT WRITE IN THIS AREA

DO NOT WRITE IN THIS AREA

10 A student investigated the way in which gamma radiation spreads out from a source. He placed a cobalt-60 source in a source holder and set up a Geiger-Müller (GM) tube a short distance d away. He connected the GM tube to a counter as shown.

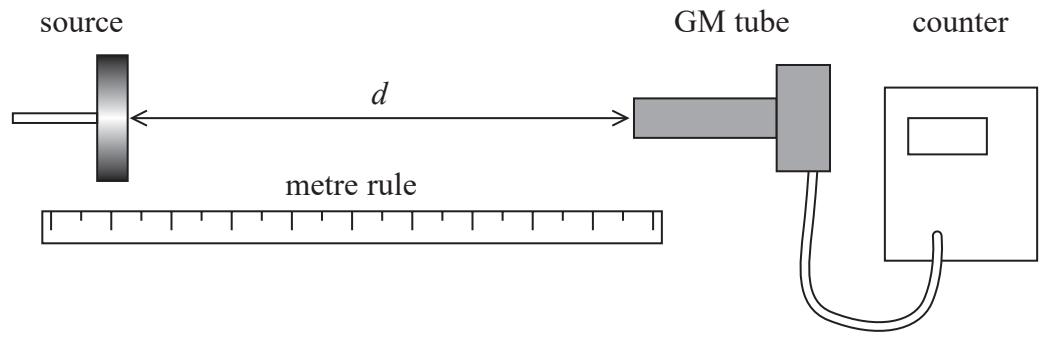

The student recorded the count for 2 minutes.

(a) Describe how to determine the corrected count rate from the source.

(2)

.....

.....

.....

.....

(b) His teacher turned the GM tube through 90° so that the side of the tube faced the source as shown below.

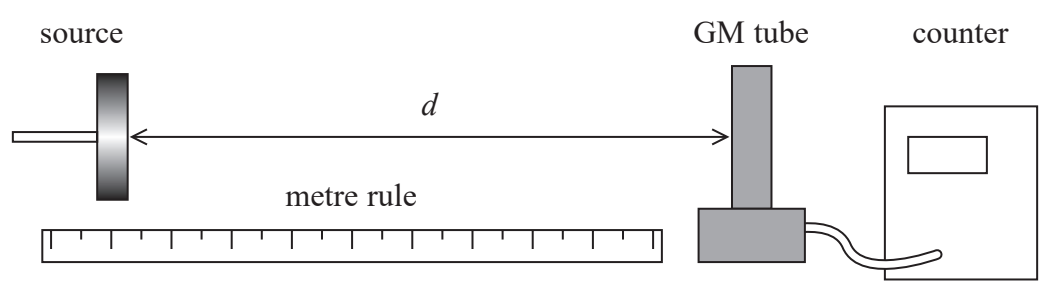

(i) Explain why this arrangement could lead to more accurate data.

(2)

.....

.....

.....

.....



(ii) Explain another modification to the experimental method which would improve the accuracy of the data.

(2)

.....

.....

.....

.....

DO NOT WRITE IN THIS AREA

DO NOT WRITE IN THIS AREA

DO NOT WRITE IN THIS AREA

(c) The variation in the intensity of gamma radiation with distance from a point source should obey an inverse square law. If this is the case, then the count rate C should vary with d according to the equation

$$C = \frac{K}{4\pi d^2}$$

where K is a constant.

The student plotted $\frac{1}{\sqrt{C}}$ against d and obtained the following graph.

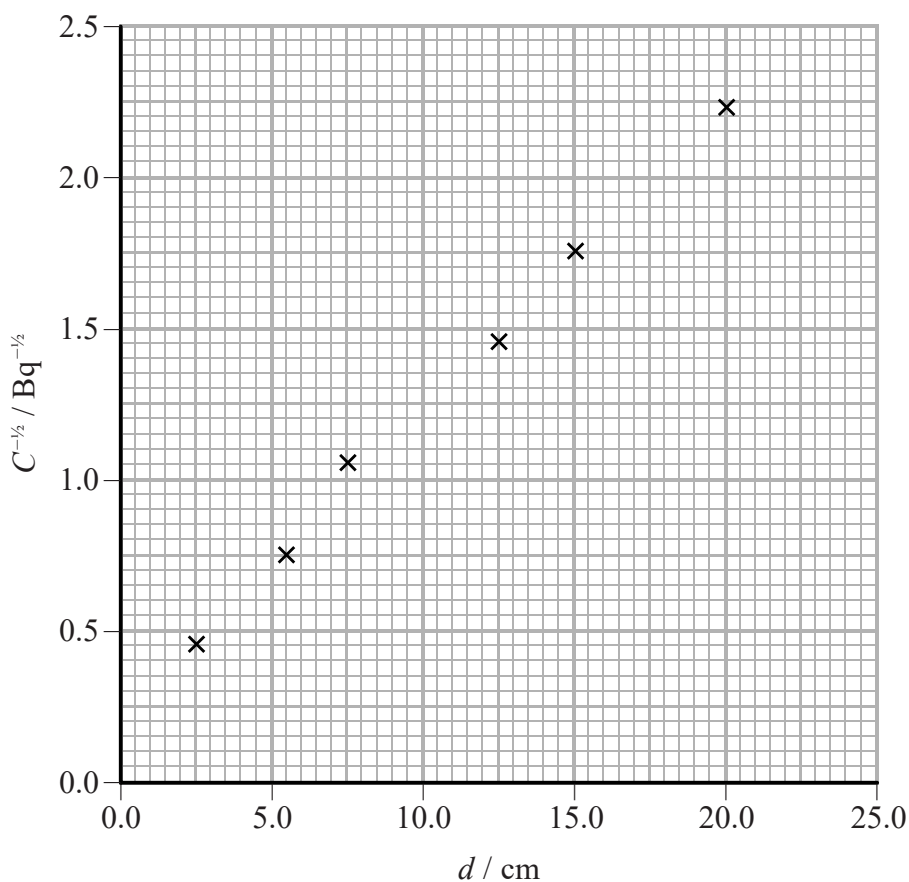

(i) Draw a line of best fit on the graph.

(1)



- (ii) The student concluded that the graph was consistent with the gamma radiation intensity obeying an inverse square law.

Discuss the extent to which the data obtained supports the student's conclusion.

(4)

.....

.....

.....

.....

.....

.....

.....

.....

.....

.....

.....

.....

.....

.....

.....

.....

.....

.....

.....

.....

.....

.....

.....

- (d) It is suggested that the investigation into the way in which gamma radiation spreads out from a source, using the apparatus as shown in (b), could be carried out successfully using a radium-226 source.

Radium-226 emits α , β and γ radiation.

Justify this suggestion.

(2)

.....

.....

.....

.....

.....

.....

.....

.....

.....

.....

.....

.....

.....

.....

.....

.....

.....

.....

.....

.....

.....

.....

(Total for Question 10 = 13 marks)

DO NOT WRITE IN THIS AREA

DO NOT WRITE IN THIS AREA

DO NOT WRITE IN THIS AREA



P 4 8 9 9 5 R R A 0 1 9 3 6

- 11 A student investigated the behaviour of a spring under tension. The spring was hung vertically with a mass holder attached.

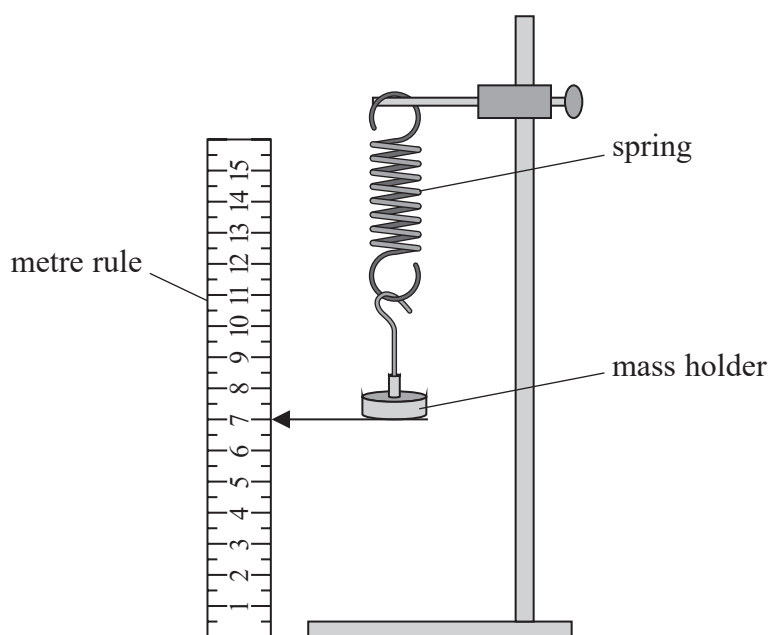

The position of the bottom of the mass holder was recorded. The spring was stretched by adding masses to the mass holder and the new positions were recorded. The extension of the spring each time was calculated.

The student produced the following table.

Mass added / g	Extension / cm	Stretching force / N
50	1.9	0.49
70	3	0.69
90	3.5	0.9
110	4.5	1.08
130	5.3	1.28
150	5.8	1.47

- (a) Criticise the student's table.

(2)

.....

.....

.....

.....

.....



DO NOT WRITE IN THIS AREA

DO NOT WRITE IN THIS AREA

DO NOT WRITE IN THIS AREA

(b) The student used her data to plot a graph as shown.

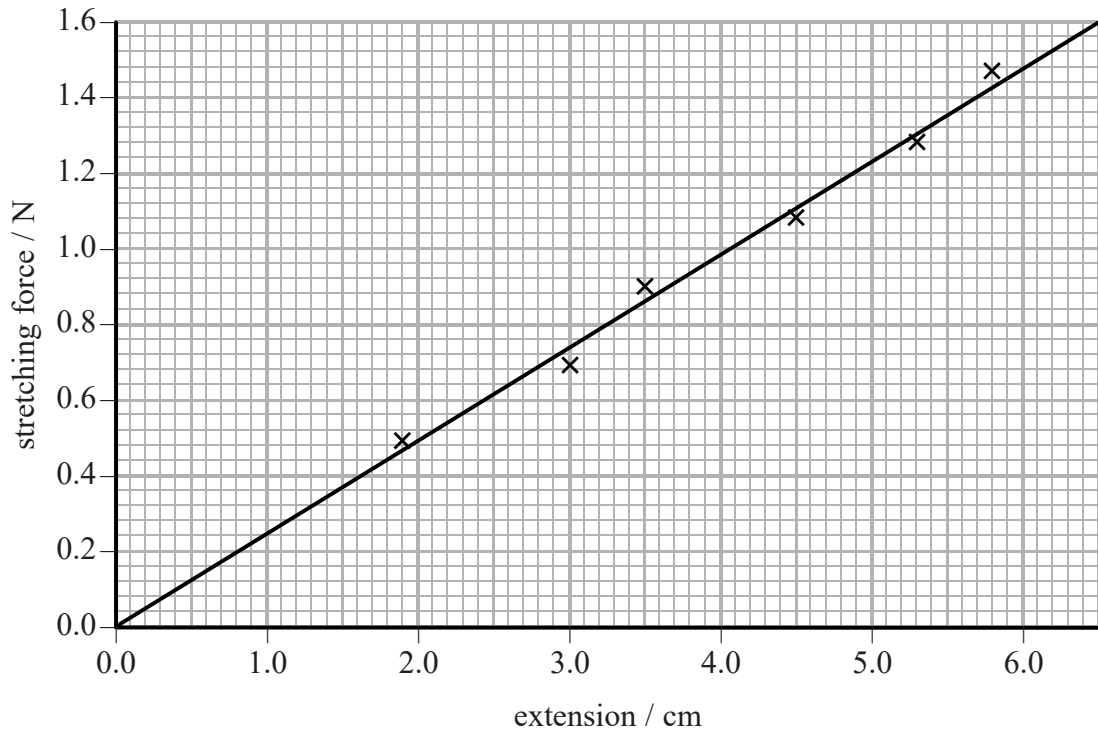

Determine a value for the force constant k of the spring.

(2)

.....

.....

.....

.....

.....

.....

.....

.....

.....

.....

$k =$



(c) Two identical springs are joined in series and a bar magnet is hung from one end as shown.

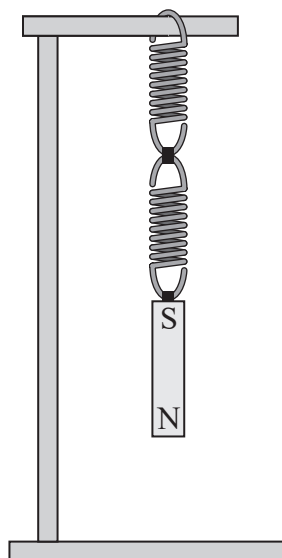

The bar magnet is displaced a small distance vertically from its equilibrium position and released.

Calculate the frequency at which the system oscillates.

mass of magnet = 120 g

spring constant of each spring = 22 N m⁻¹

(4)

Frequency =



*(d) Identical bar magnets are suspended from identical springs, with the North pole of each magnet inside a coil of wire as shown. The two coils are connected together with conducting leads.

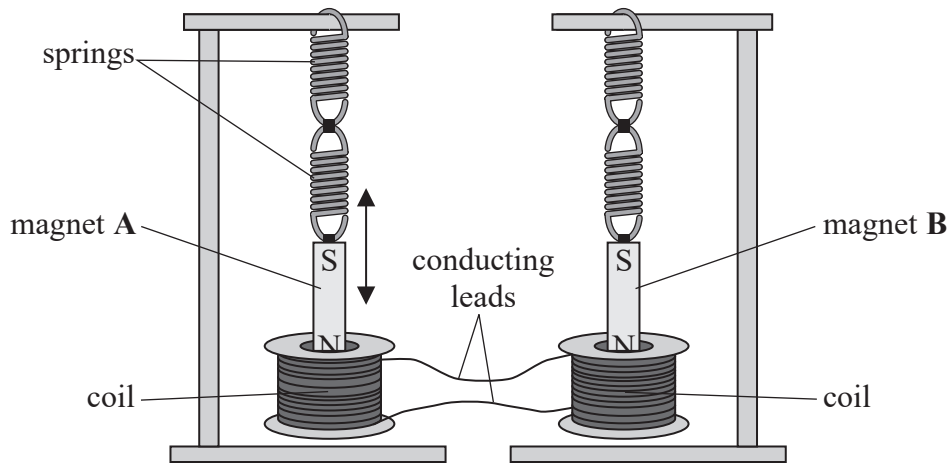

Magnet A is displaced so that it oscillates vertically. The North pole of magnet A moves into and out of the coil of wire with simple harmonic motion. As this motion continues, magnet B starts to oscillate. The amplitude of oscillation of magnet B increases over time.

Explain why magnet B starts to oscillate with an increasing amplitude.

(6)

A series of horizontal dotted lines provided for the student to write their answer.

(Total for Question 11 = 14 marks)



12 Barnard's star is a red dwarf star in the vicinity of the Sun. The wavelength of a line in the spectrum of light emitted from Barnard's star is measured to be 656.0 nm. The same light produced by a source in a laboratory has a wavelength of 656.2 nm.

(a) Calculate the velocity of Barnard's star relative to the Earth.

(3)

.....

.....

.....

.....

.....

.....

Velocity =

(b) A diffraction grating can be used to analyse the radiation emitted by a variety of sources.

(i) A diffraction grating of known grating spacing is used in a school laboratory to analyse the light emitted by a laser.

Describe how the diffraction grating is used and the measurements that should be taken.

(3)

.....

.....

.....

.....

.....

.....

.....

.....

.....

.....

.....



- (ii) A diffraction grating with grating spacing of 2.2×10^{-6} m is used to determine the difference in wavelength for the spectral line emitted by Barnard's star.

Comment on the suitability of using a diffraction grating with this spacing. You should include appropriate calculations.

(4)

.....

.....

.....

.....

.....

.....

.....

.....

.....

.....

- (c) Visible light from the star originates from the photosphere. In the photosphere of Barnard's star, hydrogen and helium atoms are at a temperature of 3100 K.

- (i) Calculate the mean kinetic energy of an atom in the photosphere at a temperature of 3100 K.

(2)

.....

.....

.....

.....

Mean kinetic energy =

- (ii) Describe how these atoms emit visible light.

(2)

.....

.....

.....

.....

.....

.....

.....

.....

(Total for Question 12 = 14 marks)

DO NOT WRITE IN THIS AREA

DO NOT WRITE IN THIS AREA

DO NOT WRITE IN THIS AREA



13 Mass spectrometry is a technique used to separate ions based on their charge to mass ratio.

The atoms in a sample are ionised and then accelerated and formed into a fine beam. This beam is passed into a region of uniform magnetic field and the ions are deflected by different amounts according to their mass.

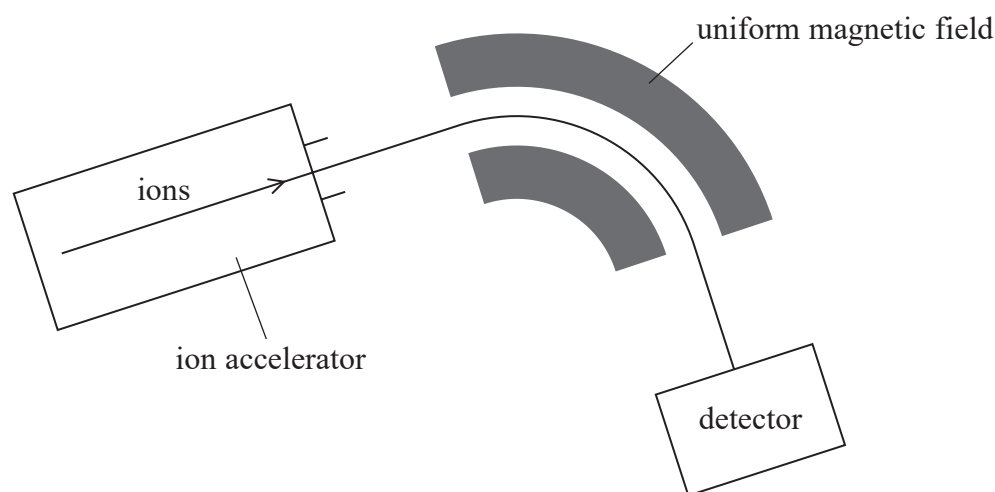

Analysis of mass spectrometer data shows that chlorine exists in nature as two isotopes, chlorine-35 and chlorine-37.

(a) State what is meant by isotopes.

(1)

(b) In a mass spectrometer, chlorine-35 ions are accelerated through a potential difference of 8.50 kV to produce an ion beam.

Show that the speed of singly ionised chlorine-35 atoms is about $2.2 \times 10^5 \text{ m s}^{-1}$.

mass of an ion of chlorine-35 = 34.97 u

(4)



- (c) In most mass spectrometers the ions are passed through a velocity selector, after being accelerated, to produce a beam of ions of a particular velocity. The velocity selector consists of a pair of parallel plates, across which a potential difference (p.d.) is applied to create an electric field.

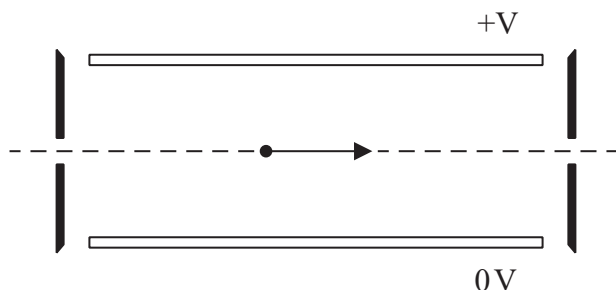

In one mass spectrometer the plates are 2.5 cm apart and a p.d. of 135 V is applied.

A magnetic field is also applied to produce a force on the ions in the opposite direction to the force from the electric field. For one particular speed the ions travel in a straight line and emerge from the selector.

- (i) Add to the diagram to indicate the directions of the electric field and the magnetic field. (2)
- (ii) The magnetic flux density applied to the velocity selector is 24.5 mT.

Deduce whether this magnetic flux density is suitable to produce a beam of chlorine-35 ions of speed $2.2 \times 10^5 \text{ m s}^{-1}$.

(4)



(d) After passing through the velocity selector the ion beam enters a region of uniform magnetic flux density 0.35 T with the ions travelling at right angles to the field direction.

(i) Explain why the ions travel in a circular path.

(2)

.....

.....

.....

.....

.....

(ii) Calculate the radius of the circular path.

(2)

.....

.....

.....

.....

.....

Radius =



(iii) The diagram shows the path of the chlorine-35 ions in the field. Chlorine-37 ions enter the magnetic field with the same velocity.

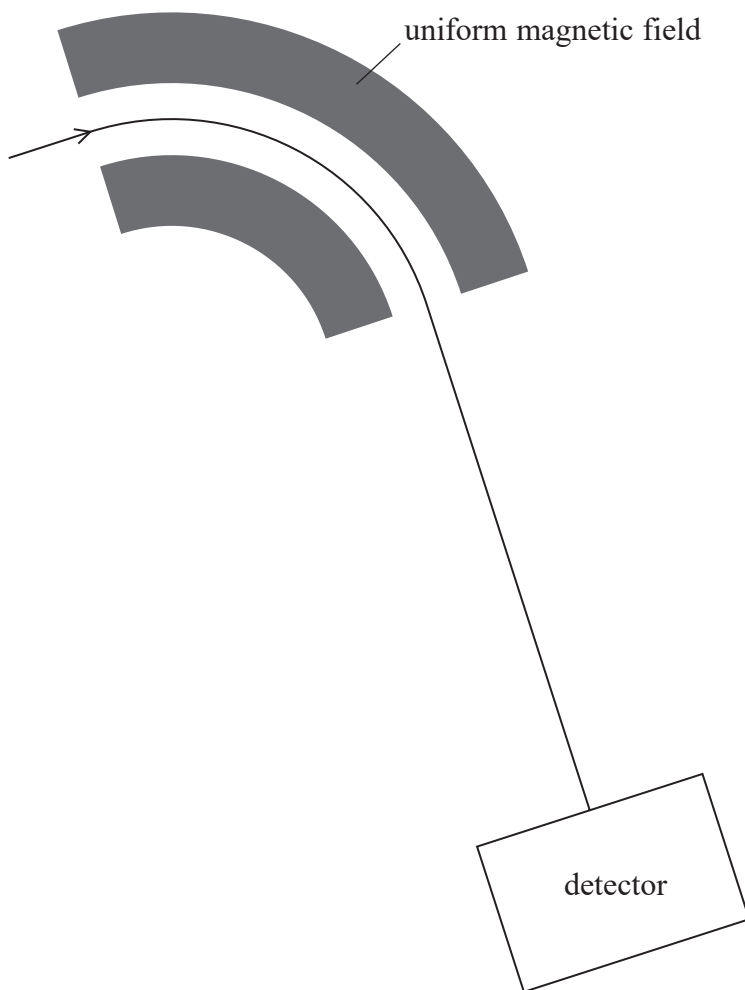

1. Add another line to the diagram to show the path of these chlorine-37 ions.

(1)

2. Explain any differences in the paths.

(2)

.....

.....

.....

.....

.....

.....

(Total for Question 13 = 18 marks)

TOTAL FOR PAPER = 120 MARKS



P 4 8 9 9 5 R R A 0 2 9 3 6

DO NOT WRITE IN THIS AREA

DO NOT WRITE IN THIS AREA

DO NOT WRITE IN THIS AREA

List of data, formulae and relationships

Acceleration of free fall	$g = 9.81 \text{ m s}^{-2}$	(close to Earth's surface)
Boltzmann constant	$k = 1.38 \times 10^{-23} \text{ J K}^{-1}$	
Coulomb law constant	$k = \frac{1}{4\pi\epsilon_0} = 8.99 \times 10^9 \text{ N m}^2 \text{ C}^{-2}$	
Electron charge	$e = -1.60 \times 10^{-19} \text{ C}$	
Electron mass	$m_e = 9.11 \times 10^{-31} \text{ kg}$	
Electronvolt	$1 \text{ eV} = 1.60 \times 10^{-19} \text{ J}$	
Gravitational constant	$G = 6.67 \times 10^{-11} \text{ N m}^2 \text{ kg}^{-2}$	
Gravitational field strength	$g = 9.81 \text{ N kg}^{-1}$	(close to Earth's surface)
Permittivity of free space	$\epsilon_0 = 8.85 \times 10^{-12} \text{ F m}^{-1}$	
Planck constant	$h = 6.63 \times 10^{-34} \text{ J s}$	
Proton mass	$m_p = 1.67 \times 10^{-27} \text{ kg}$	
Speed of light in a vacuum	$c = 3.00 \times 10^8 \text{ m s}^{-1}$	
Stefan-Boltzmann constant	$\sigma = 5.67 \times 10^{-8} \text{ W m}^{-2} \text{ K}^{-4}$	
Unified atomic mass unit	$u = 1.66 \times 10^{-27} \text{ kg}$	

Mechanics

Kinematic equations of motion

$$s = \frac{(u + v)t}{2}$$

$$v = u + at$$

$$s = ut + \frac{1}{2}at^2$$

$$v^2 = u^2 + 2as$$

Forces

$$\Sigma F = ma$$

$$g = \frac{F}{m}$$

$$W = mg$$

$$\text{moment of force} = Fx$$

Momentum

$$p = mv$$

Work, energy and power

$$\Delta W = F\Delta s$$

$$E_k = \frac{1}{2}mv^2$$

$$\Delta E_{\text{grav}} = mg\Delta h$$

$$P = \frac{E}{t}$$

$$P = \frac{W}{t}$$

$$\text{efficiency} = \frac{\text{useful energy output}}{\text{total energy input}}$$

$$\text{efficiency} = \frac{\text{useful power output}}{\text{total power input}}$$



Electric circuits

Potential difference

$$V = \frac{W}{Q}$$

Resistance

$$R = \frac{V}{I}$$

Electrical power and energy

$$P = VI$$

$$P = I^2R$$

$$P = \frac{V^2}{R}$$

$$W = VIt$$

Resistivity

$$R = \frac{\rho l}{A}$$

Current

$$I = \frac{\Delta Q}{\Delta t}$$

$$I = nqvA$$

Materials

Density

$$\rho = \frac{m}{V}$$

Stokes' law

$$F = 6\pi\eta rv$$

Hooke's law

$$\Delta F = k\Delta x$$

Young modulus

$$\text{Stress } \sigma = \frac{F}{A}$$

$$\text{Strain } \varepsilon = \frac{\Delta x}{x}$$

$$E = \frac{\sigma}{\varepsilon}$$

Elastic strain energy

$$\Delta E_{\text{el}} = \frac{1}{2}F\Delta x$$

Waves and Particle Nature of Light

Wave speed

$$v = f\lambda$$

Speed of a transverse wave on a string

$$v = \sqrt{\frac{T}{\mu}}$$

Intensity of radiation

$$I = \frac{P}{A}$$

Power of a lens

$$P = \frac{1}{f}$$

$$P = P_1 + P_2 + P_3 + \dots$$

Thin lens equation

$$\frac{1}{u} + \frac{1}{v} = \frac{1}{f}$$

Magnification for a lens

$$m = \frac{\text{image height}}{\text{object height}} = \frac{v}{u}$$

Diffraction grating

$$n\lambda = d \sin \theta$$



Refractive index

$$n_1 \sin \theta_1 = n_2 \sin \theta_2$$

$$n = \frac{c}{v}$$

Critical angle

$$\sin C = \frac{1}{n}$$

Photon model

$$E = hf$$

Einstein's photoelectric equation

$$hf = \phi + \frac{1}{2}mv_{\max}^2$$

de Broglie wavelength

$$\lambda = \frac{h}{p}$$

Further mechanics

Impulse

$$F\Delta t = \Delta p$$

Kinetic energy of a non-relativistic particle

$$E_k = \frac{p^2}{2m}$$

Motion in a circle

$$v = \omega r$$

$$T = \frac{2\pi}{\omega}$$

$$F = ma = \frac{mv^2}{r}$$

$$a = \frac{v^2}{r}$$

$$a = r\omega^2$$

Centripetal force

$$F = \frac{mv^2}{r}$$

$$F = mr\omega^2$$

Fields

Coulomb's law

$$F = k \frac{Q_1 Q_2}{r^2}$$

$$\text{where } k = \frac{1}{4\pi\epsilon_0}$$

Electric field strength

$$E = \frac{F}{Q}$$

$$E = k \frac{Q}{r^2}$$

$$E = \frac{V}{d}$$

Electric potential

$$V = k \frac{Q}{r}$$

Capacitance

$$C = \frac{Q}{V}$$

Energy stored in a capacitor

$$W = \frac{1}{2}QV$$

Capacitor discharge

$$Q = Q_0 e^{-t/RC}$$

Resistor – capacitor discharge

$$I = I_0 e^{-t/RC}$$

$$V = V_0 e^{-t/RC}$$

In a magnetic field

$$F = BIl \sin \theta$$

$$F = Bqv \sin \theta$$

Faraday's and Lenz's laws

$$\epsilon = \frac{-d(N\phi)}{dt}$$

Root-mean-square values

$$V_{\text{rms}} = \frac{V_0}{\sqrt{2}}$$

$$I_{\text{rms}} = \frac{I_0}{\sqrt{2}}$$



Nuclear and particle physics

In a magnetic field

$$r = \frac{p}{BQ}$$

Thermodynamics

Heating

$$\Delta E = mc\Delta\theta$$

$$\Delta E = L\Delta m$$

Molecular kinetic theory

$$\frac{1}{2}m\langle c^2 \rangle = \frac{3}{2}kT$$

$$pV = \frac{1}{3}Nm\langle c^2 \rangle$$

Ideal gas equation

$$pV = NkT$$

Stefan-Boltzmann law

$$L = \sigma AT^4$$

$$L = \sigma 4\pi r^2 T^4$$

Wien's law

$$\lambda_{\max} T = 2.898 \times 10^{-3} \text{ m K}$$

Space

Intensity

$$I = \frac{L}{4\pi d^2}$$

Redshift of electromagnetic radiation

$$z = \frac{\Delta\lambda}{\lambda} \approx \frac{\Delta f}{f} \approx \frac{v}{c}$$

Cosmological expansion

$$v = H_0 d$$

Nuclear radiation

Mass-energy

$$\Delta E = c^2\Delta m$$

Radioactive decay

$$A = \lambda N$$

$$\frac{dN}{dt} = -\lambda N$$

$$\lambda = \frac{\ln 2}{t_{1/2}}$$

$$N = N_0 e^{-\lambda t}$$

$$A = A_0 e^{-\lambda t}$$

Gravitational fields

Gravitational force

$$F = \frac{Gm_1 m_2}{r^2}$$

Gravitational field strength

$$g = \frac{Gm}{r^2}$$

Gravitational potential

$$V_{\text{grav}} = \frac{-Gm}{r}$$

Oscillations

Simple harmonic motion

$$F = -kx$$

$$a = -\omega^2 x$$

$$x = A \cos \omega t$$

$$v = -A\omega \sin \omega t$$

$$a = -A\omega^2 \cos \omega t$$

$$T = \frac{1}{f} = \frac{2\pi}{\omega}$$

$$\omega = 2\pi f$$

Simple harmonic oscillator

$$T = 2\pi \sqrt{\frac{m}{k}}$$

$$T = 2\pi \sqrt{\frac{l}{g}}$$



DO NOT WRITE IN THIS AREA

DO NOT WRITE IN THIS AREA

DO NOT WRITE IN THIS AREA

BLANK PAGE



DO NOT WRITE IN THIS AREA

DO NOT WRITE IN THIS AREA

DO NOT WRITE IN THIS AREA

BLANK PAGE



DO NOT WRITE IN THIS AREA

DO NOT WRITE IN THIS AREA

DO NOT WRITE IN THIS AREA

BLANK PAGE

Every effort has been made to contact copyright holders to obtain their permission for the use of copyright material. Pearson Education Ltd. will, if notified, be happy to rectify any errors or omissions and include any such rectifications in future editions.

