

Write your name here

Surname

Other names

**Pearson**  
**Edexcel GCSE**

Centre Number

--	--	--	--	--

Candidate Number

--	--	--	--	--

# Mathematics B

**Unit 3: Number, Algebra, Geometry 2 (Calculator)**

**Higher Tier**

Tuesday 10 November 2015 – Morning

**Time: 1 hour 45 minutes**

Paper Reference

**5MB3H/01**

**You must have:** Ruler graduated in centimetres and millimetres, protractor, pair of compasses, pen, HB pencil, eraser, calculator. Tracing paper may be used.

Total Marks

## Instructions

- Use **black** ink or ball-point pen.
- **Fill in the boxes** at the top of this page with your name, centre number and candidate number.
- Answer **all** questions.
- Answer the questions in the spaces provided – *there may be more space than you need.*
- **Calculators may be used.**
- If your calculator does not have a  $\pi$  button, take the value of  $\pi$  to be 3.142 unless the question instructs otherwise.



## Information

- The total mark for this paper is 80
- The marks for **each** question are shown in brackets – *use this as a guide as to how much time to spend on each question.*
- Questions labelled with an **asterisk** (\*) are ones where the quality of your written communication will be assessed.

## Advice

- Read each question carefully before you start to answer it.
- Keep an eye on the time.
- Try to answer every question.
- Check your answers if you have time at the end.

Turn over ►

P45908A

©2015 Pearson Education Ltd.

6/6/6/



**PEARSON**

# GCSE Mathematics 2MB01

Formulae: Higher Tier

**You must not write on this formulae page.  
Anything you write on this formulae page will gain NO credit.**

**Volume of prism** = area of cross section  $\times$  length

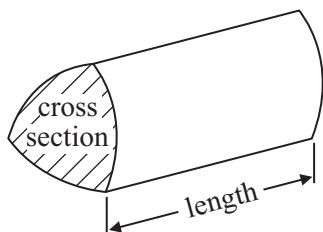

**Area of trapezium** =  $\frac{1}{2} (a + b)h$

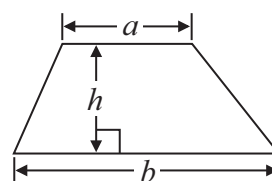

**Volume of sphere** =  $\frac{4}{3} \pi r^3$

**Surface area of sphere** =  $4\pi r^2$

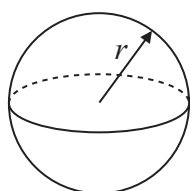

**Volume of cone** =  $\frac{1}{3} \pi r^2 h$

**Curved surface area of cone** =  $\pi r l$

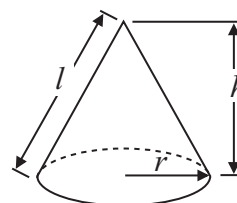

**In any triangle ABC**

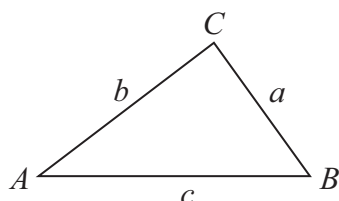

**The Quadratic Equation**

The solutions of  $ax^2 + bx + c = 0$  where  $a \neq 0$ , are given by

$$x = \frac{-b \pm \sqrt{b^2 - 4ac}}{2a}$$

**Sine Rule**  $\frac{a}{\sin A} = \frac{b}{\sin B} = \frac{c}{\sin C}$

**Cosine Rule**  $a^2 = b^2 + c^2 - 2bc \cos A$

**Area of triangle** =  $\frac{1}{2} ab \sin C$



**Answer ALL questions.**

**Write your answers in the spaces provided.**

**You must write down all stages in your working.**

1 (a) Work out the value of  $\frac{4.5 + \sqrt{10}}{3.1}$

Give your answer correct to 2 decimal places.

.....  
(2)

(b) Work out the value of

$$\frac{1}{2.5 \times 10^{-3}}$$

.....  
(1)

**(Total for Question 1 is 3 marks)**

---



2 The diagram shows the positions of a lighthouse and a harbour on a map.

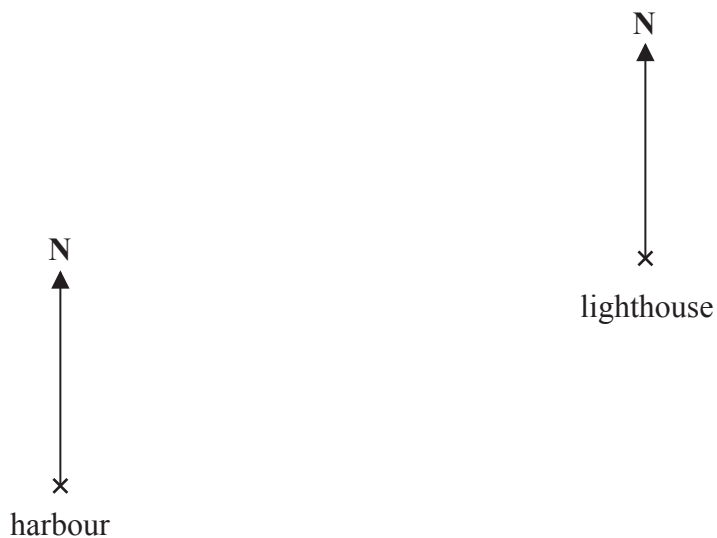

A boat is on a bearing of

- $300^\circ$  from the lighthouse
- $040^\circ$  from the harbour.

(a) On the diagram, mark with a cross ( $\times$ ) the position of the boat.  
Label the boat *B*.

(3)

The scale of the map is 1 cm represents 50 000 cm.

(b) Work out the real distance from the harbour to the lighthouse.  
Give your answer in km.

..... km  
(2)

**(Total for Question 2 is 5 marks)**



\*3 A supermarket has two special offers on lemonade.

**Bottles of lemonade**

Special offer

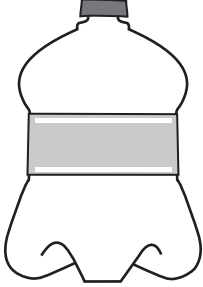

15% off the normal price of each bottle

**Cans of lemonade**

Special offer



Buy 3 cans get 25p off the total cost

The normal price of a 2.5 litre bottle of lemonade is £1.60

The normal price of a 0.33 litre can of lemonade is 28p.

Jerry is going to buy 4 bottles of the lemonade on special offer or 30 cans of the lemonade on special offer.

Which special offer is the better value for money?

(Total for Question 3 is 5 marks)



4

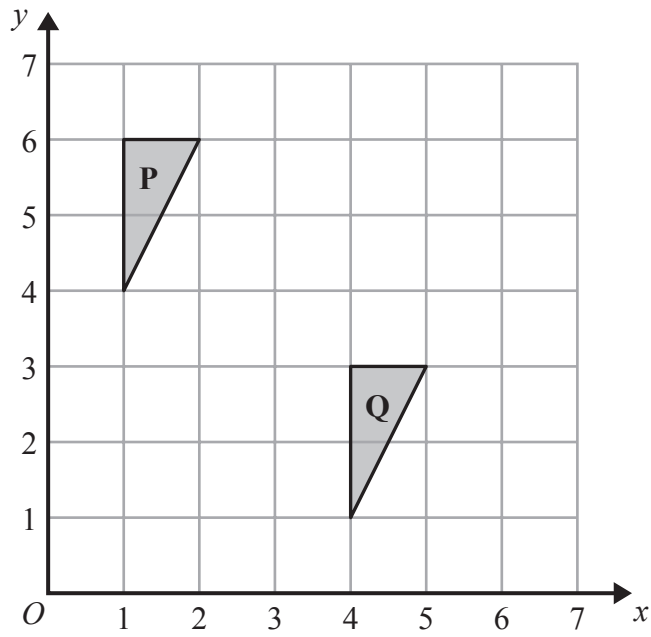

(a) Describe fully the single transformation that maps shape **P** to shape **Q**.

(2)

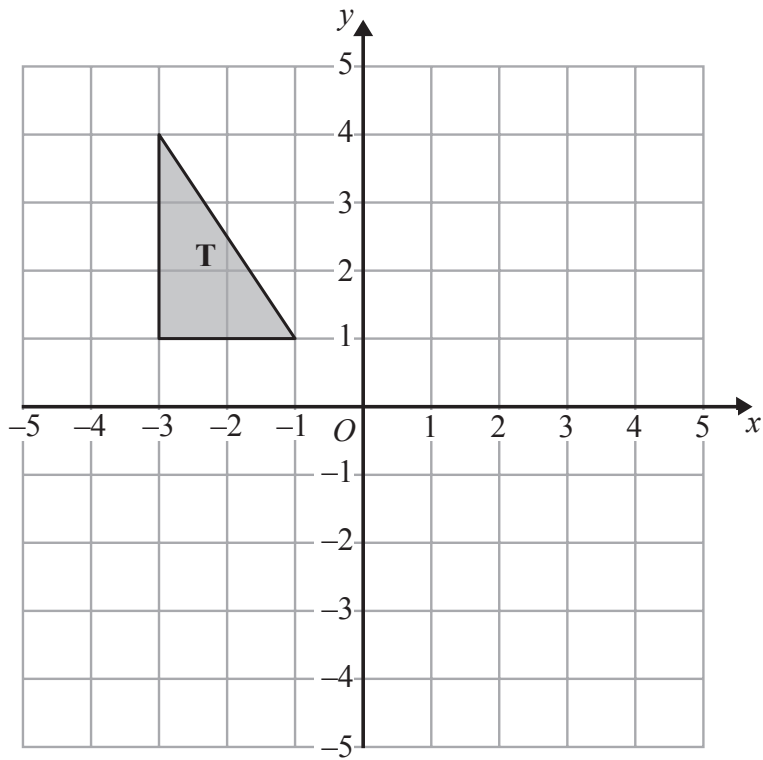

(b) Rotate triangle **T**  $180^\circ$  about the point  $(0, 1)$ .

(2)

(Total for Question 4 is 4 marks)

6



5 Harry has a cable.  
The cable has a length of 16 metres.

Harry cuts the cable into two parts, part *A* and part *B*.

The length of part *A* is 5 metres.  
The weight of part *A* is 8 kg.

Work out the weight of part *B*.

.....kg

**(Total for Question 5 is 3 marks)**

---



6

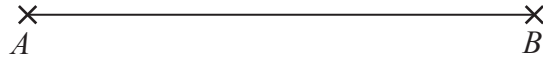

Use ruler and compasses to **construct** the perpendicular bisector of the line  $AB$ .  
You must show all your construction lines.

**(Total for Question 6 is 2 marks)**

---





7 The equation  $x^3 - 9x = 48$   
has a solution between 4 and 5

Use a trial and improvement method to find the solution.  
Give your answer correct to one decimal place.  
You must show **all** your working.

$x = \dots\dots\dots$

**(Total for Question 7 is 4 marks)**

---



8 The diagram shows a prism.

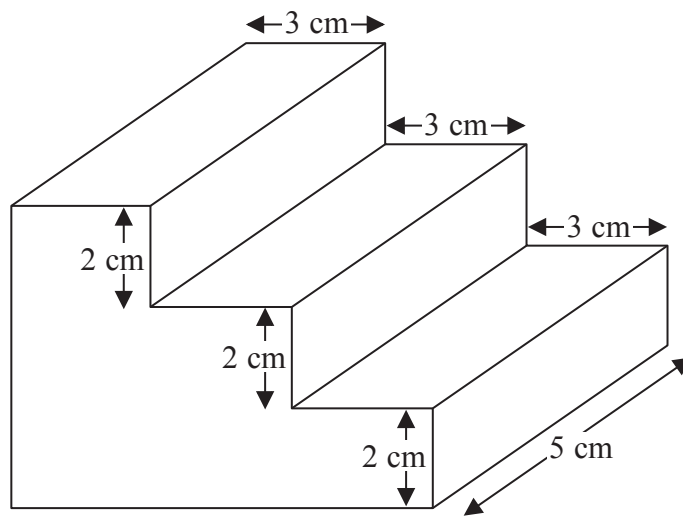

Diagram **NOT**  
accurately drawn

All the corners are right angles.

Work out the volume of the prism.

.....cm<sup>3</sup>

**(Total for Question 8 is 3 marks)**



9 (a) Complete the table of values for  $y = 4 - x^2$

$x$	-3	-2	-1	0	1	2	3
$y$	-5		3			0	

(2)

(b) On the grid, draw the graph of  $y = 4 - x^2$  for values of  $x$  from -3 to 3

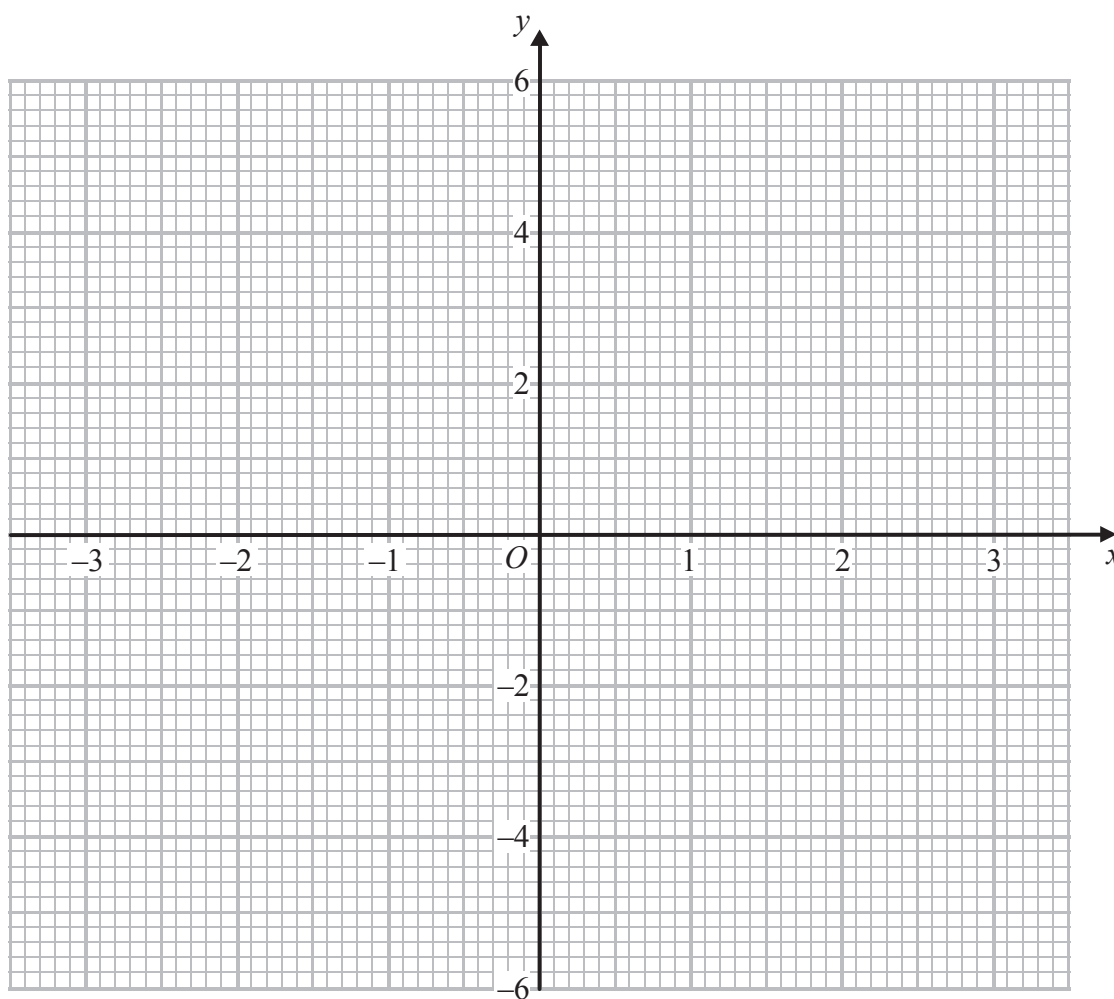

(2)

(Total for Question 9 is 4 marks)



**10** Hilary, Imogen and Jeeha are playing a game with cards.

Imogen has 3 cards more than Hilary.

Jeeha has twice as many cards as Imogen.

They have a total of 53 cards.

Work out how many cards Hilary has.

.....  
**(Total for Question 10 is 4 marks)**

---



11

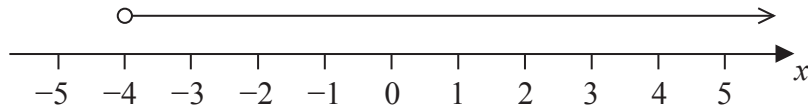

(a) Write down the inequality represented on the number line.

.....  
(1)

(b) Solve  $4y - 9 \leq 3$

.....  
(2)

(c)  $-3 \leq n < 2$   
 $-2 < m < 4$   
 $n$  and  $m$  are integers.

Given that  $n = m$ , write down all the possible values of  $n$ .

.....  
(2)

(Total for Question 11 is 5 marks)



**12** Jade makes an orange drink by mixing orange concentrate with water.

She mixes  $15 \text{ cm}^3$  of orange concentrate with  $250 \text{ cm}^3$  of water.

The density of orange concentrate is  $1.20 \text{ g/cm}^3$ .

The density of water is  $1.00 \text{ g/cm}^3$ .

Work out the density of Jade's orange drink.

Give your answer correct to 2 decimal places.

..... $\text{g/cm}^3$

**(Total for Question 12 is 3 marks)**

---



\*13 The value of a motor bike depreciates by 20% each year.

Brian says,

“After two years, the value of the motor bike will have reduced by 40%”.

He is **wrong**.

Explain why.

---

(Total for Question 13 is 3 marks)



14 Make  $t$  the subject of the formula

$$p = \sqrt{\frac{3t}{a}}$$

.....  
**(Total for Question 14 is 3 marks)**

---





15 The diagram shows a pond.

Diagram **NOT**  
accurately drawn

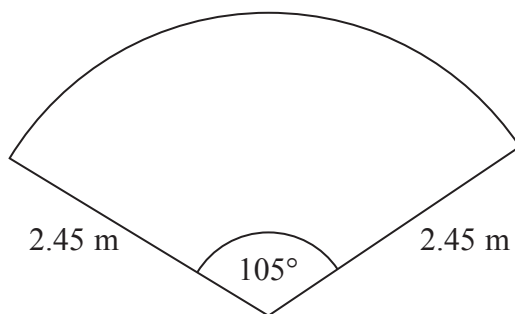

The pond is in the shape of a sector of a circle.

Toby is going to put edging on the perimeter of the pond.

Edging is sold in lengths of 1.75 metres.

Each length of edging costs £3.49

Work out the total cost of edging Toby needs to buy.

£ .....

(Total for Question 15 is 5 marks)



16 Solve  $\frac{x+1}{2} + \frac{2x-1}{3} = \frac{5}{6}$

$x = \dots\dots\dots$

**(Total for Question 16 is 4 marks)**

---



\*17

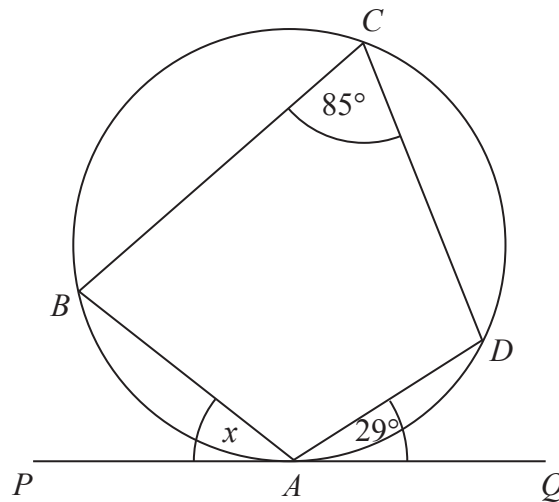

Diagram **NOT**  
accurately drawn

In the diagram,

- the points  $A$ ,  $B$ ,  $C$  and  $D$  are on the circumference of a circle
- the line  $PAQ$  is a tangent to the circle
- angle  $DAQ = 29^\circ$
- angle  $BCD = 85^\circ$

Work out the size of the angle marked  $x$ .  
Give a reason for each stage of your working.

(Total for Question 17 is 3 marks)



P 4 5 9 0 8 A 0 1 9 2 4

18 Solve  $6x^2 - x - 15 = 0$

---

**(Total for Question 18 is 3 marks)**

---



**19**  $y$  is proportional to  $x^2$ .

When  $x = 5$ ,  $y = 100$

Work out the value of  $y$  when  $x = 3$

$y = \dots\dots\dots$

**(Total for Question 19 is 3 marks)**

---



20  $I = \frac{V}{R}$

$V = 250$  correct to the nearest 5

$R = 3900$  correct to the nearest 100

Work out the lower bound for the value of  $I$ .  
Give your answer correct to 3 decimal places.  
You must show your working.

.....  
(Total for Question 20 is 3 marks)

---



21

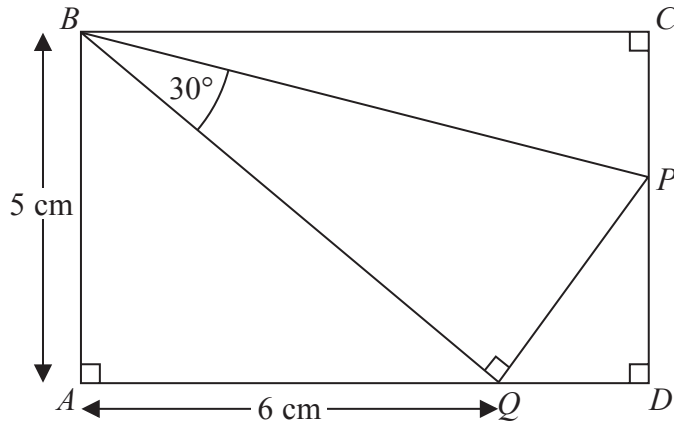

Diagram **NOT** accurately drawn

In the diagram,

- $ABCD$  is a rectangle
- $P$  lies on the line  $CD$
- $Q$  lies on the line  $AD$
- $PQB$  is a right-angled triangle

Work out the length of  $BC$ .

Give your answer correct to 3 significant figures.

You must show your working.

.....cm

(Total for Question 21 is 5 marks)



22 Here is the graph of  $y = f(x)$ .

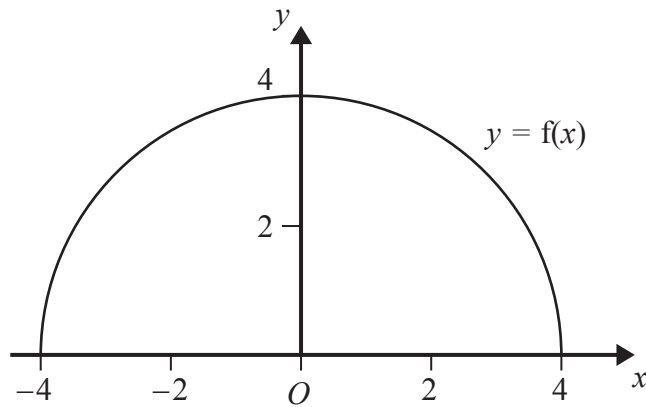

(a) Write down the coordinates of the point where the graph of  $y = f(x) - 3$  meets the  $y$ -axis.

(....., .....)  
(1)

The graph of  $y = f(4x)$  meets the  $x$ -axis at the points  $P$  and  $Q$ .

(b) Work out the length of the line segment  $PQ$ .

.....  
(2)

(Total for Question 22 is 3 marks)

TOTAL FOR PAPER IS 80 MARKS

