

Wednesday 1 December 2021– Afternoon

GCSE (9–1) Physics A (Gateway Science)

J249/04 Paper 4 (Higher Tier)

Time allowed: 1 hour 45 minutes

You must have:

- a ruler (cm/mm)
- the Data Sheet for GCSE (9–1) Physics A (inside this document)

You can use:

- a scientific or graphical calculator
- an HB pencil



Please write clearly in black ink. **Do not write in the barcodes.**

Centre number

--	--	--	--	--

Candidate number

--	--	--	--

First name(s)

Last name

INSTRUCTIONS

- Use black ink. You can use an HB pencil, but only for graphs and diagrams.
- Write your answer to each question in the space provided. If you need extra space use the lined pages at the end of this booklet. The question numbers must be clearly shown.
- Answer **all** the questions.
- Where appropriate, your answer should be supported with working. Marks might be given for using a correct method, even if your answer is wrong.

INFORMATION

- The total mark for this paper is **90**.
- The marks for each question are shown in brackets [].
- Quality of extended response will be assessed in questions marked with an asterisk (*).
- This document has **28** pages.

ADVICE

- Read each question carefully before you start your answer.

2
SECTION A

Answer **all** the questions.

You should spend a maximum of 30 minutes on this section.

Write your answer to each question in the box provided.

- 1 Carbon-12 is an isotope of carbon.

Carbon-12 contains 6 protons and 6 neutrons.

Which atom **X** is also an isotope of carbon?

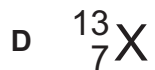
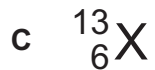
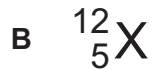
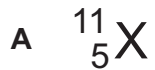

Your answer

[1]

- 2 A student makes a wave in a ripple tank.

The student measures distance, L .

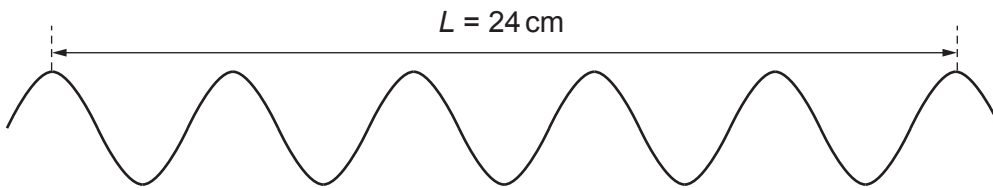

What is the wavelength of the wave?

A 2.4 cm

B 4.0 cm

C 4.8 cm

D 24 cm

Your answer

[1]

3 Which statement about infra red radiation is correct?

- A Infra red has the shortest wavelength in the electromagnetic spectrum.
- B Infra red is emitted by humans.
- C Infra red is next to radio waves in the electromagnetic spectrum.
- D White objects absorb more infra red than black objects.

Your answer

[1]

4 Estimate the force needed to accelerate a car at 1 m/s^2 .

- A 10 N
- B 100 N
- C 1000 N
- D 10000 N

Your answer

[1]

5 How can unwanted energy transfer be reduced?

- A By adding lubrication
- B By decreasing efficiency
- C By increasing friction
- D By removing thermal insulation

Your answer

[1]

- 6 A cork floats on water. Ripples move across the surface of the water.

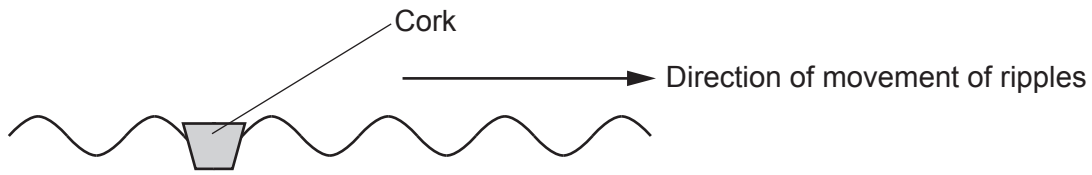

Which statement describes the motion of the cork?

- A It does not move.
- B It moves in the same direction as the direction of movement of the ripples.
- C It moves sideways parallel to the direction of movement of the ripples.
- D It moves up and down.

Your answer

[1]

- 7 The two statements describe the mains electricity supply:

- The a.c. potential difference between the earth wire and the live wire is **X** volts.
- The a.c. potential difference between the earth wire and the neutral wire is **Y** volts.

Which row of the table correctly completes the sentences?

	X	Y
A	0	0
B	0	230
C	230	0
D	230	230

Your answer

[1]

8 Four stages in the lifecycle of a star are P, Q, R and S:

P	Nuclear fusion starts.
Q	The core collapses to form a white dwarf.
R	Dust and gas are pulled together by gravity.
S	The star expands to form a red giant.

What is the correct order of these stages?

A P → R → Q → S

B P → S → R → Q

C R → P → S → Q

D R → Q → P → S

Your answer

[1]

9 Which answer equals 2.45×10^9 Hz?

A 2.45 GHz

B 2.45 kHz

C 2.45 MHz

D 2.45 THz

Your answer

[1]

- 10 A student uses a glass prism to split white light into different colours.

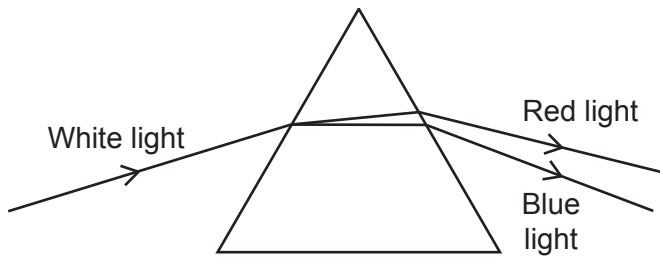

Which statement describes the light in the prism?

- A Blue light is refracted less than red light.
- B Blue light slows down more than red light.
- C Red light has a shorter wavelength than blue light.
- D Red light has a smaller frequency change than blue light.

Your answer

[1]

- 11 A teacher measures the activity of a radioactive source. They place different materials between the radioactive source and detector.

The results are shown in the table:

Material	Activity (counts per minute)
Air only	325
Sheet of paper	337
Aluminium, 5 mm thick	26
Lead, 15 mm thick	24

Which type of radiation is emitted by the radioactive source?

- A Alpha and beta particles only
- B Alpha particles only
- C Beta particles only
- D Gamma rays and beta particles only

Your answer

[1]

12 An electrical circuit has an alternating current.

What type of wave can be produced by the alternating current?

- A Gamma rays
- B Radio
- C Ultraviolet
- D X-rays

Your answer

[1]

13 An atom loses an electron after absorbing some electromagnetic radiation.

Which row of the table describes what happens?

	Energy of electron	Charge on the atom
A	Decreases	Negative
B	Decreases	Positive
C	Increases	Negative
D	Increases	Positive

Your answer

[1]

14 Two students, **A** and **B**, climb some steps.

- Student **A** has twice the mass of student **B**.
- Student **B** climbs four times higher than student **A**.

Which statement about gravitational potential energy (GPE) is correct?

Use the equation: potential energy = mass \times height \times gravitational field strength

- A GPE gain of student **B** = $\frac{1}{4}$ \times GPE gain of student **A**
- B GPE gain of student **B** = $\frac{1}{2}$ \times GPE gain of student **A**
- C GPE gain of student **B** = 2 \times GPE gain of student **A**
- D GPE gain of student **B** = 4 \times GPE gain of student **A**

Your answer

[1]

15 A student calculates braking distance using this equation:

$$(\text{final velocity})^2 - (\text{initial velocity})^2 = 2 \times \text{acceleration} \times \text{distance}$$

What is the correct equation for braking distance?

A Braking distance = $(\text{final velocity})^2 - (\text{initial velocity})^2 - 2 \times \text{acceleration}$

B Braking distance = $\frac{(\text{final velocity})^2}{(\text{initial velocity})^2} - 2 \times \text{acceleration}$

C Braking distance = $2 \times \text{acceleration} \times ((\text{final velocity})^2 - (\text{initial velocity})^2)$

D Braking distance = $\frac{(\text{final velocity})^2 - (\text{initial velocity})^2}{2 \times \text{acceleration}}$

Your answer

[1]

9
BLANK PAGE

PLEASE DO NOT WRITE ON THIS PAGE

SECTION B

Answer **all** the questions.

16 This question is about visible light.

(a) (i) State **one** change that happens to light when it travels from water into air.

..... [1]

(ii) Diagram in **Fig. 16.1** shows a ray of light from a fish in a container of water.

Complete the ray diagram in **Fig. 16.1** to show the path of the ray after it leaves the water.

Include a normal line in your diagram.

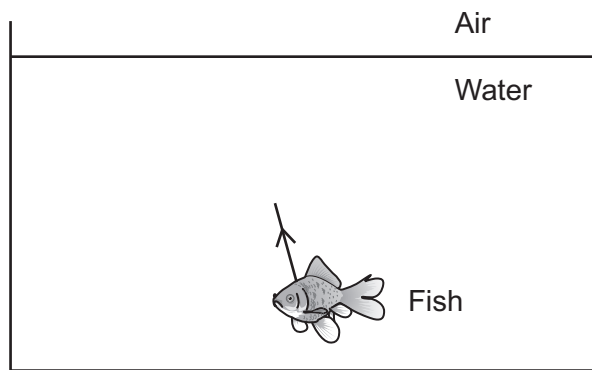

Fig. 16.1

[3]

(b) Diagram in **Fig. 16.2** shows three incident rays hitting the surface of the fish. Light is scattered from the surface of the fish.

Complete the diagram in **Fig. 16.2** to show the scattered rays.

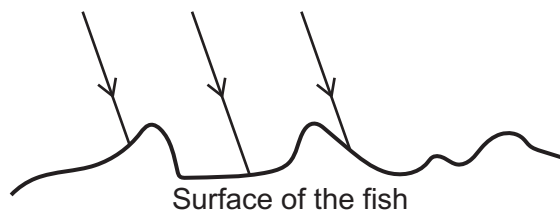

Fig. 16.2

[1]

(c) The fish appears red under white light.

Explain why the fish appears black under green light.

.....

.....

..... [2]

17 A solar cell changes light into electricity. Solar panels contain solar cells.

(a) A student investigates a solar cell:

- They change the intensity of the light.
- They measure the potential difference across the solar cell.

(i) **Table 17.1** shows the student's results:

Light intensity (W/m^2)	Potential difference (V)
0.05	0.8
0.10	1.2
0.20	1.5
0.40	1.8
0.80	2.2
1.60	2.5

Table 17.1

Plot a graph of the results from **Table 17.1**. Two results have already been plotted for you.

Draw a line of best fit.

[3]

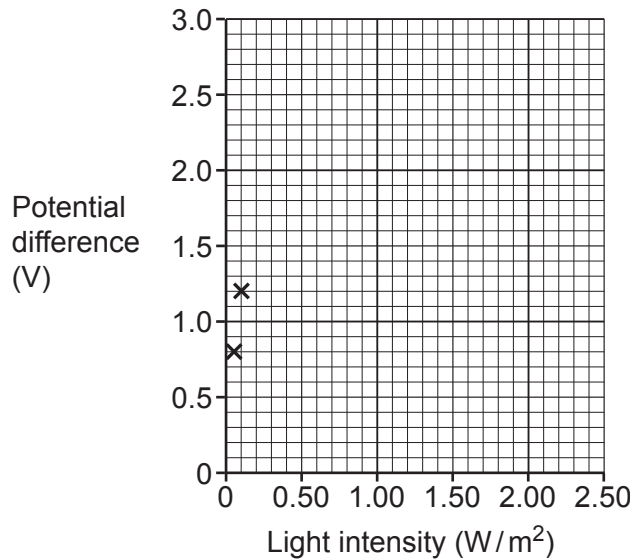

(ii) The light intensity is changed to 2.00 W/m^2 .

Use your graph to predict the potential difference of the solar cell.

Show your working on the graph.

Potential difference = V [2]

(iii) Suggest **one** way the student could improve their investigation.

.....
 [1]

(b) (i) More people use solar panels to generate electricity compared to twenty years ago.

Suggest **two** reasons why.

1

 2
 [2]

(ii) A homeowner fits solar panels to the roof of their house.

Table 17.2 gives the energy values for the house for **one** day:

Area of one solar panel	1.6 m ²
Area of roof that can be used	24 m ²
Maximum energy output of one solar panel	26 MJ
Energy needed by all appliances in the house	364 MJ

Table 17.2

Explain whether the energy needed by all the appliances can be generated using **only** solar panels.

Use **Table 17.2** and your knowledge of solar panels to explain your answer.

.....

 [3]

18 This question is about radioactive Plutonium-238 (Pu-238).

(a) Pu-238 can be used to produce electricity:

- The Pu-238 undergoes radioactive decay.
- This causes the temperature of the plutonium to increase.
- Electricity is produced.

Complete the sentences using the words below.

You can use each word once, more than once, or not at all.

chemical elastic potential electrostatic
gravitational potential nuclear thermal

The energy store of the plutonium decreases.

The energy store of the plutonium increases.

[1]

(b) (i) State why Pu-238 undergoes radioactive decay.

.....
 [1]

(ii) A Pu-238 nucleus emits an alpha particle.



Determine the value of the mass of the nucleus **and** the number of protons **after** Pu-238 emits an alpha particle.

Mass of the nucleus

Number of protons

[2]

(c) Fig. 18.1 shows how the activity of Pu-238 changes with time.

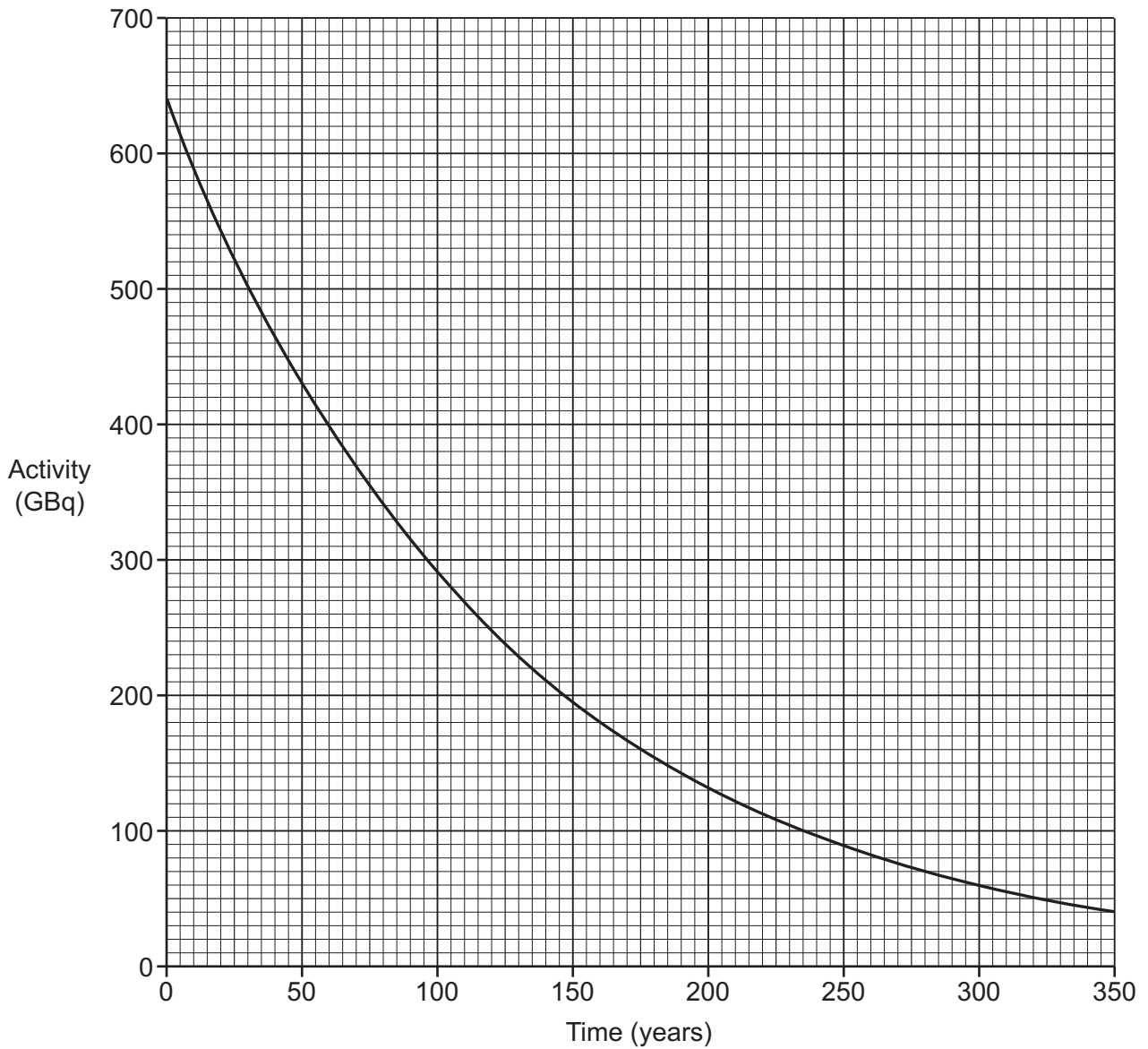

Fig. 18.1

Use Fig. 18.1 to find the half-life for Pu-238.

Show your working on the graph.

Half-life = years [2]

(d) (i) A different isotope of plutonium is used in nuclear **fission**.

Describe how a chain reaction occurs in nuclear **fission**.

.....
.....
.....
..... [2]

(ii) Nuclear **fusion** occurs in the Sun.

Describe what is meant by nuclear **fusion**.

.....
..... [1]

19 A radio signal is sent to Mars.

(a) **Table 19.1** shows the distance from the Sun to Earth and the distance from the Sun to Mars, when Mars and Earth are closest.

Distance from the Sun to Earth	$1.50 \times 10^{11} \text{ m}$
Distance from the Sun to Mars	$2.28 \times 10^{11} \text{ m}$

Table 19.1

The radio signal travels at 300 000 000 m/s.

Calculate the minimum time for the radio signal to travel from Earth to Mars.

Use the data in **Table 19.1** and the equation: distance = speed \times time

Time = s [4]

(b) The average surface temperature on Earth is 15 °C.

Suggest whether the average temperature on Mars is higher or lower than 15 °C.

Use the data in **Table 19.1** to explain your answer.

.....

.....

.....

.....

.....

..... [2]

20 A student uses an electric heater to raise the temperature of water.

Fig. 20.1 shows some of the equipment the student uses.

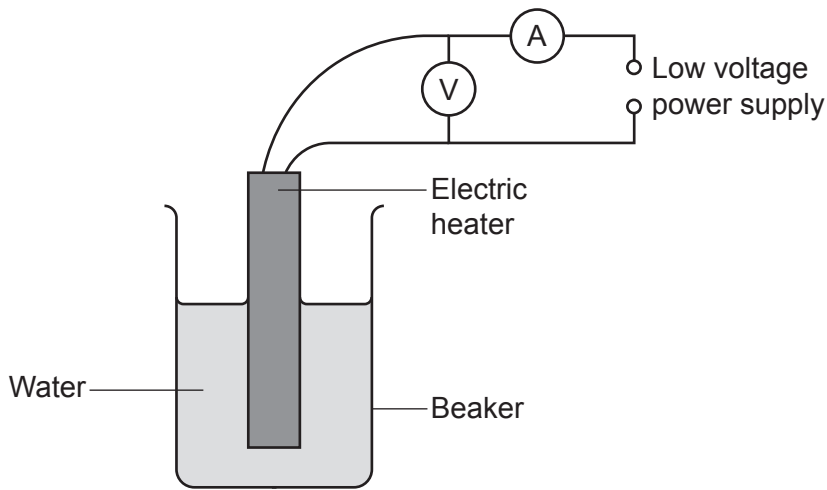

Fig. 20.1

The student obtains the data in Table 20.1:

Energy input to the heater	12 000 J
Increase in thermal energy store of the water	8 400 J

Table 20.1

(a) Use the data in Table 20.1 to calculate the efficiency of the heater.

Efficiency = [3]

21 Two springs are used to make a catapult. The catapult is used to shoot a ball vertically upwards.

The diagram shows the ball and catapult at different stages:

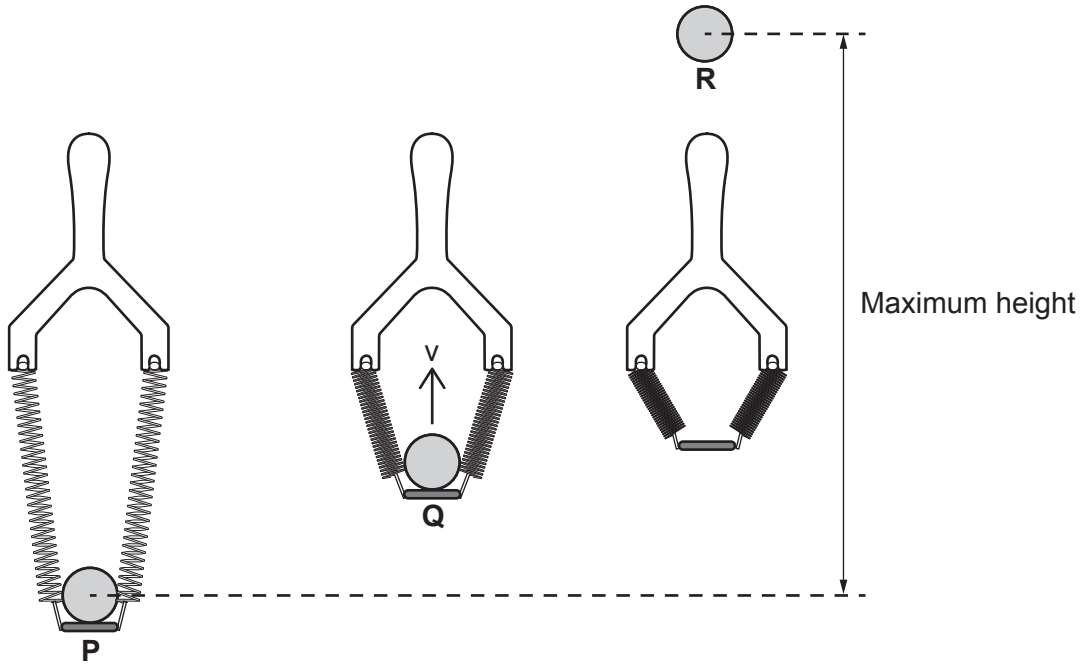

(a) At **P** the extension of each spring is 0.2 m.

The spring constant of each spring is 40 N/m.

Calculate the **total** elastic potential energy stored in the springs at **P**.

Energy stored = J [3]

(b) At **Q** the ball is released and has maximum kinetic energy. The springs have **no** extension at **Q**.

The kinetic energy of the ball at **Q** is **less** than the value of the elastic potential energy stored in the springs at **P**.

Explain why.

.....
.....
..... [2]

(c) The springs are stretched to a new extension:

- The total energy stored in the two springs is 2.4 J.
- The mass of the ball is 0.050 kg.
- At **R** the ball reaches maximum height.

Calculate the maximum height reached by the ball.

Use the equation: potential energy = mass × height × gravitational field strength

Maximum height = m [4]

(d) A student investigates how the mass of the ball affects its speed at **Q**.

Describe **one** factor the student should control in their investigation.

.....
..... [1]

22 A van travels along a road at a constant speed.

(a) The van brakes and decelerates at a constant rate:

- The initial speed of the van is 18 m/s.
- The deceleration of the van is 1.5 m/s².

Calculate the time taken for the van to stop.

Use the equation: acceleration = change in velocity / time taken

Time = s [3]

(b) The same van travels on an **icy** road at 18 m/s.

Explain how the **stopping** distance changes.

Write about thinking and braking in your answer.

.....
.....
.....
.....
..... [3]

(c) If the van crashes, the time taken to stop is much smaller.

Explain why this is dangerous for the people in the van.

.....
.....
..... [2]

23
BLANK PAGE

PLEASE DO NOT WRITE ON THIS PAGE

23 This question is about infra red (IR) and ultra violet (UV) radiation.

(a) It took humans a long time to discover IR and UV radiation.

Suggest **two** reasons why.

1

.....

2

..... [2]

(b) Look at the information about some UV radiation:

- The wavelength of the UV radiation is $0.18 \mu\text{m}$.
- The wave speed of the UV radiation is $3.0 \times 10^8 \text{m}$.

Calculate the frequency of the UV radiation.

Use the equation: wave speed = frequency \times wavelength

Give your answer to **2** significant figures.

Frequency = Hz [5]

(c) The ozone layer is part of the Earth's atmosphere.

This graph shows how the percentage of UV radiation **transmitted** by the ozone layer depends on wavelength:

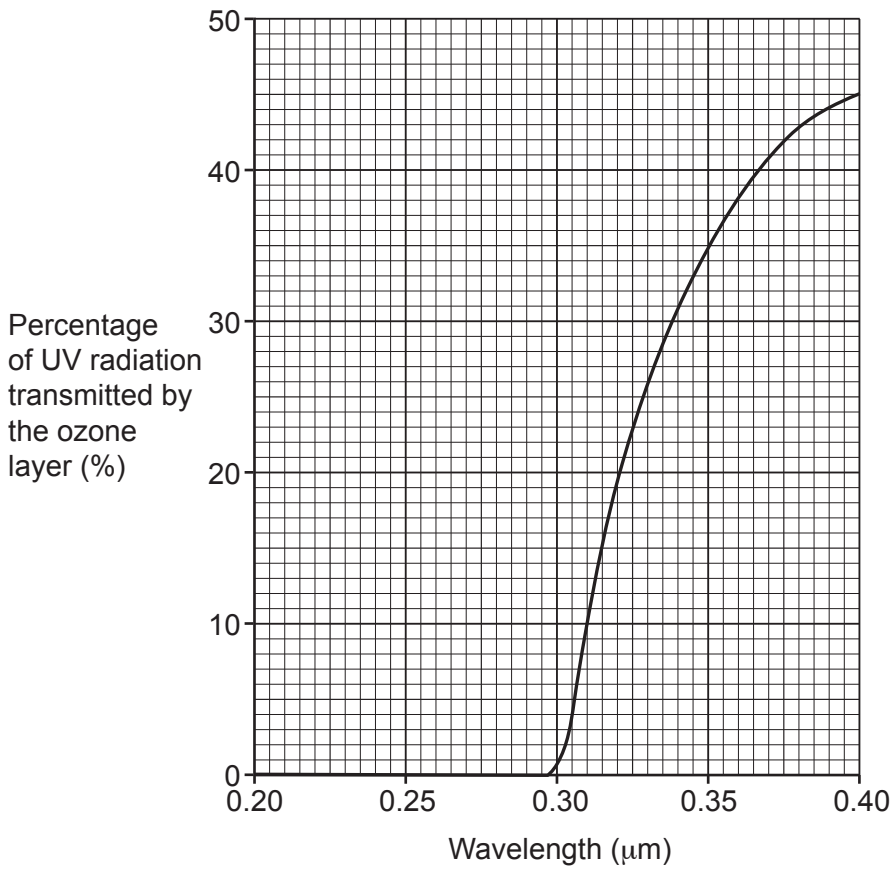

(i) Describe the difference in the **absorption** of UV radiation at 0.31 µm and 0.37 µm.

Use data from the graph in your answer.

.....

.....

.....

..... [3]

(ii) Why is the ozone layer important for humans on Earth?

Use the graph to help explain your answer.

.....

.....

.....

..... [2]

ADDITIONAL ANSWER SPACE

If additional space is required, you should use the following lined page(s). The question number(s) must be clearly shown in the margin(s).

A large area of lined paper for writing. It consists of a vertical solid line on the left side, creating a margin. To the right of this line, there are numerous horizontal dotted lines spaced evenly down the page, providing a guide for writing.

