

A Level Physics B (Advancing Physics)
H557/03 Practical skills in physics
Sample Question Paper

Date – Morning/Afternoon

Version 2.1

Time allowed: 1 hour 30 minutes



You must have:

- the Data, Formulae and Relationships Booklet

You may use:

- a scientific or graphical calculator



o o o o o o *

First name										
Last name										
Centre number										
Candidate number										

INSTRUCTIONS

- Use black ink. You may use an HB pencil for graphs and diagrams.
- Complete the boxes above with your name, centre number and candidate number.
- Answer **all** the questions.
- Where appropriate, your answers should be supported with working. Marks may be given for a correct method even if the answer is incorrect.
- Write your answer to each question in the space provided.
- Additional paper may be used if required but you must clearly show your candidate number, centre number and question number(s).
- Do **not** write in the bar codes.

INFORMATION

- The total mark for this paper is **60**.
- The marks for each question are shown in brackets [].
- Quality of extended responses will be assessed in questions marked with an asterisk (*).
- This document consists of **16** pages.

SECTION A

Answer **all** the questions.

- 1 A teacher uses strobe photography to demonstrate the motion of a tennis ball thrown under gravity. She opens the camera shutter in a darkened room and throws the tennis ball in front of the lens as the strobe flashes at 20 ± 2 Hz. **Fig. 1** shows the result, superimposed on a metric grid.



Fig.1 is a graph showing the result superimposed on a metric grid. This item has been removed due to third party copyright restrictions.

For other examples of this type of question please see our past papers, available through our website and Interchange. Alternatively, see our ExamBuilder platform for the full list of relevant mock questions.

A student takes measurements of the y position from **Fig. 1**, starting from the image centred on $x = 0.20$ m. He measures the y positions from the bottom of the ball and performs calculations; some are recorded in the table below. He concludes that g , the acceleration of gravity, is $9.2 \pm 0.4 \text{ m s}^{-2}$.

t / s $\pm 10\%$	y / m $\pm 0.005 \text{ m}$	$\Delta y / \text{m}$	$\Delta y / \Delta t / \text{m s}^{-1}$	$\Delta v / \text{m s}^{-1}$	$\Delta v / \Delta t / \text{m s}^{-2}$
0	0.54				
0.05	0.52	0.02	0.40		
0.10	0.48	0.04	0.80	0.40	
0.15	0.42	0.06	1.20	0.40	
0.20	0.33	0.09	1.80		
0.25	0.22	0.11	2.20		
0.30	0.10	0.12	2.40		

- (a) (i) Record further values in the spaces provided to complete the data in the table. [2]

- (ii) Complete your own analysis of the data by calculating the mean value for g with an estimate of its uncertainty.

$g = \dots \pm \dots \text{ m s}^{-2}$ [2]

- (iii) You are planning to improve the accuracy of this experiment to estimate g . Suggest and explain which of the measured quantities is most worth improving to achieve this.

.....

.....

.....

.....

.....

.....

.....

.....

.....

..... [2]

- (b) (i)* It is suggested that the horizontal velocity component of the motion is constant at 1.0 m s^{-1} . Test this hypothesis, making your method clear. Explain your judgement and conclusion.

You may wish to use the table provided to record values taken from **Fig. 1**.

[6]

Additional answer space if required.

- (ii) The teacher states that the vertical and horizontal components of the motion shown illustrate Newton's first two laws of motion.

Explain how the two components of the motion could illustrate these laws of motion.

.....

.....

.....

.....

.....

.....

.....

[2]

- 2 The experiment illustrated in **Fig. 2.1** is to be used to investigate aspects of the electric field between parallel plates. The charged ball bounces continuously between the plates.

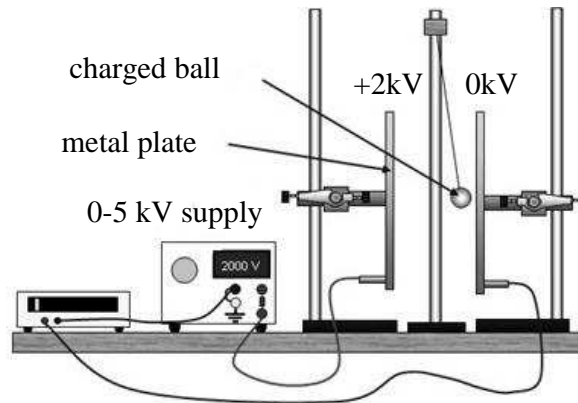

Fig. 2.1

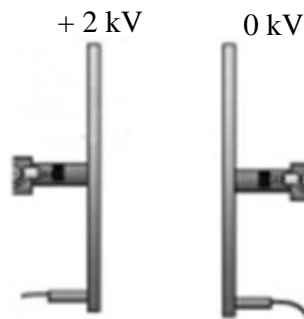

Fig. 2.2

- (a) (i) **Fig. 2.2** shows a close up of the parallel plates.

Draw five lines on **Fig. 2.2** to represent the uniform electric field between the plates. Add a labelled line to represent the + 500 V equipotential.

[3]

- (ii) State the effect on the electric field strength between the plates of:

1 halving the separation of the plates

.....

.....

2 halving the p.d. from the supply.

.....

.....

[2]

- (b) (i) Calculate the force on the ball when charged to +2.0 kV and placed between the plates with a p.d. of 2.0 kV.

radius of ball = 2.0×10^{-2} m
plate separation = 8.0×10^{-2} m

force = N [3]

- (ii) Calculate or state the work done by the electric field per coulomb on the ball as the ball moves across half the separation of the plates.

work done per unit charge = J C⁻¹ [1]

- (c) The ball bounces between the plates at a constant rate.

Explain why the ball bounces at a constant rate although it gains energy from the electric field each time it moves between the plates.

.....

.....

.....

.....

.....

.....

.....

.....

.....

..... [2]

3 **Fig. 3.1** shows a short bar magnet being dropped vertically through a small horizontal coil.

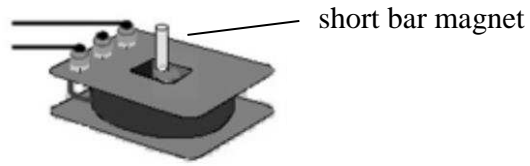

Fig. 3.1

Fig. 3.2 shows the graph of how the e.m.f. induced in the coil varies with time, as the magnet passes through the coil.

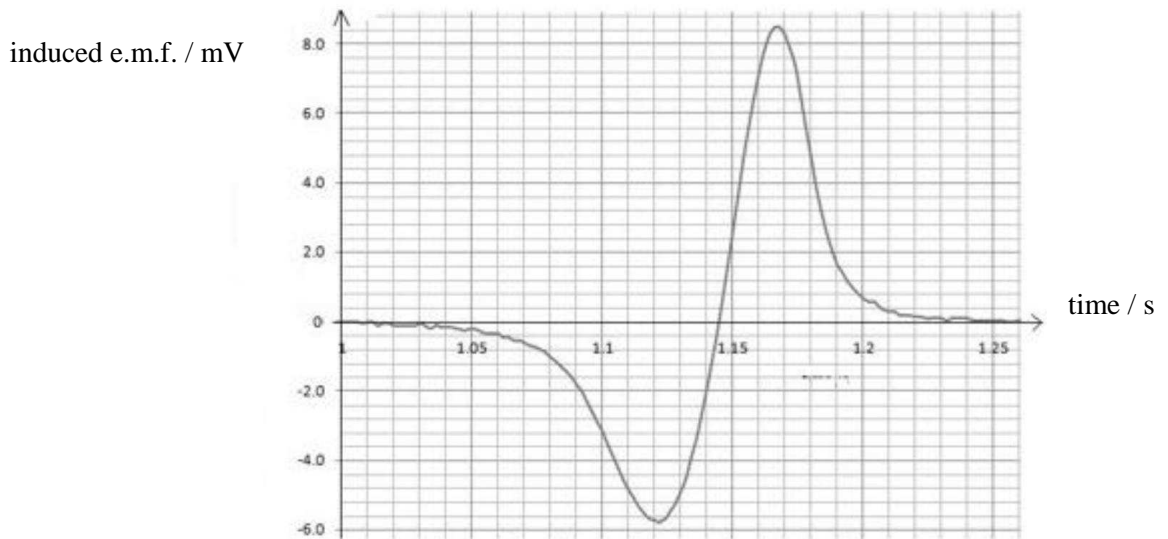

Fig. 3.2

(a)* Identify and explain the main features of the peaks of induced emf shown on **Fig. 3.2**, in terms of Faraday's law of electromagnetic induction. **[6]**

.....

.....

.....

.....

.....

.....

.....

.....

.....

.....

- (b) An experiment is being planned for dropping a much longer bar magnet through the small coil of **Fig. 3.1** and measuring the induced emf.

Sketch and label an apparatus diagram.

State **one** aspect that would need to be controlled in order to obtain accurate data and explain how you would achieve this.

[3]

3 (c) Explain how the graph in **Fig. 3.2** would change if:

1 a much longer bar magnet replaced the short bar magnet.

.....
.....
.....

2 a much larger diameter coil replaced the small coil.

.....
.....
.....

[4]

(d) The data in **Fig. 3.2** were obtained using an 1100 turn coil.

Calculate the total flux linking the coil from when the magnet **enters** the coil to the point at which the magnet is central within the coil.

flux linked =Wb [2]

SECTION B

Answer **all** the questions.

- 4 A student wanted to use a capacitor and a resistor in an electronic timer. She used the circuit shown in **Fig. 4.1** to test a capacitor **C** and variable resistor **R₂**.

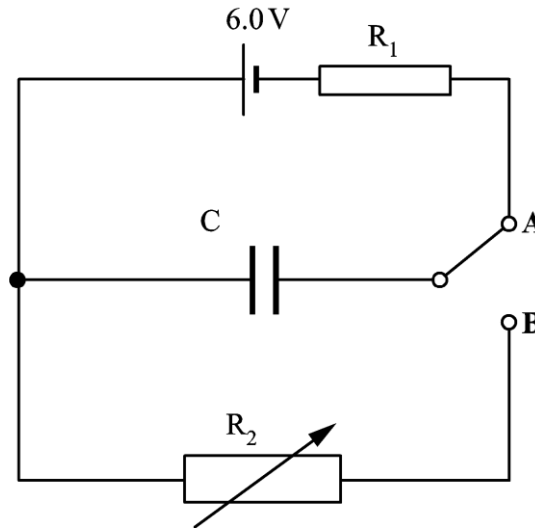

Fig. 4.1

In one test the capacitor was first charged through the fixed resistor **R₁** by connecting the switch to **A**. It was then discharged through the variable resistor **R₂** by connecting the switch to **B**. The student used a data-logger to measure how the voltage across capacitor **C** varied as it charged and then discharged through the two different resistors. A data table of her results is shown in **Fig. 4.2**.

charging through R_1		discharging through R_2	
t / ms	$\text{p.d.}_1 / \text{V}$	t / s	$\text{p.d.}_2 / \text{V}$
0	0.00	0	6.00
2	0.46	2	5.54
4	0.89	4	5.11
6	1.28	6	4.72
8	1.65	8	4.35
10	1.98	10	4.02
12	2.29	12	3.71
14	2.58	14	3.42
16	2.84	16	3.16
18	3.09	18	2.91
20	3.31	20	2.69
22	3.52	22	2.48
24	3.71	24	2.29
26	3.89	26	2.11
28	4.05	28	1.95
30	4.20	30	1.80

Fig.4.2

- (a) **Figs. 4.3a** and **4.3b** show the charge and discharge curves for the data in the table in **Fig. 4.2**.

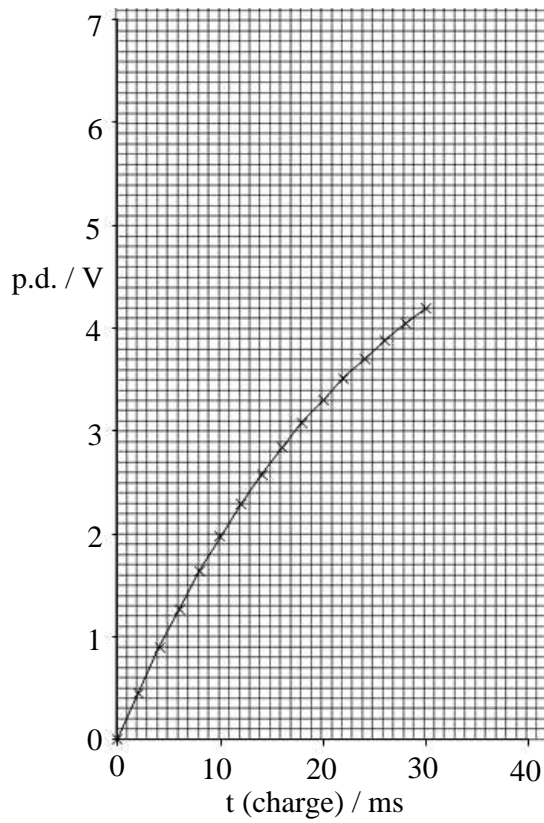

Fig. 4.3a

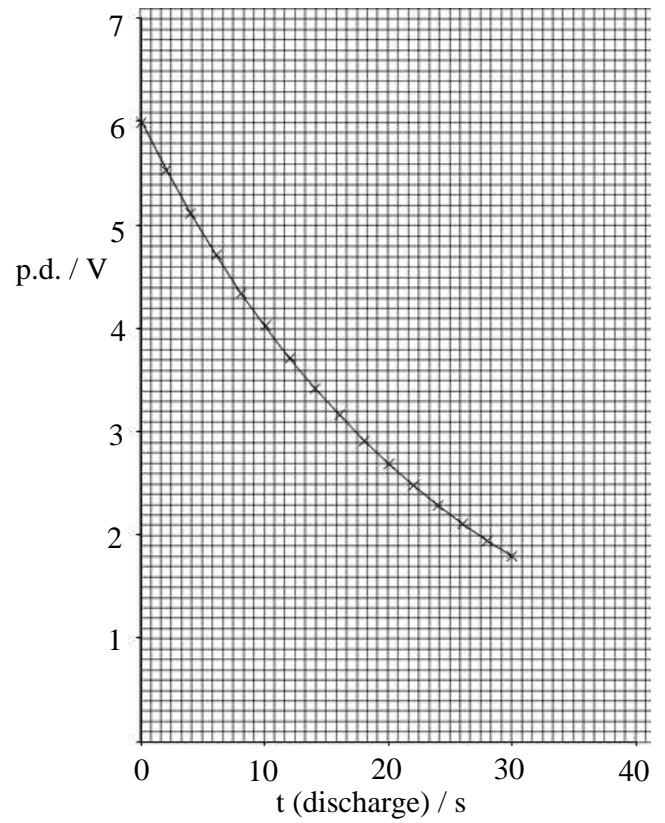

Fig. 4.3b

- (i) Using the graph of **Fig. 4.3b**, show that the time constant for the discharge is less than 30 seconds.

[3]

- (ii) The capacitor has a value of $4700 \mu\text{F}$. Show that the initial discharge current would be about 1 mA .

[4]

- (iii)* The student calculated the total amount of charge to flow from the capacitor in the first 30 seconds. She used two methods:

Method 1 – using the relationship $\Delta Q = C \Delta V$

Method 2 – using $I = \frac{V}{R}$ and the area under the $I(t)$ graph where R is $5.0 \text{ k}\Omega$

Show how the total charge flow may be calculated in both cases and comment on how the two methods compare.

[6]

- (b) In the student's proposed timer, the p.d. across R_2 must fall to 1.0 V in less than 50 seconds.

Use suitable calculations to demonstrate whether the circuit meets this requirement.

[4]

- (c) Calculate the value of the charging resistor R_1 .

resistance = Ω [3]

END OF QUESTION PAPER

Copyright Information:

Adapted diagram of Shuttle-ball experiment, Electric Current > Episode 102: Current as flow of charge. IOP, 2011. Available at http://tap.iop.org/electricity/current/102/page_45896.html

OCR is committed to seeking permission to reproduce all third-party content that it uses in the assessment materials. OCR has attempted to identify and contact all copyright holders whose work is used in this paper. To avoid the issue of disclosure of answer-related information to candidates, all copyright acknowledgements are reproduced in the OCR Copyright Acknowledgements booklet. This is produced for each series of examinations and is freely available to download from our public website (www.ocr.org.uk) after the live examination series.

If OCR has unwittingly failed to correctly acknowledge or clear any third-party content in this assessment material, OCR will be happy to correct its mistake at the earliest possible opportunity.

For queries or further information please contact the Copyright Team, First Floor, 9 Hills Road, Cambridge CB2 1GE.

OCR is part of the Cambridge Assessment Group; Cambridge Assessment is the brand name of University of Cambridge Local Examinations Syndicate (UCLES), which is itself a department of the University of Cambridge.