

Centre Number						Candidate Number				
Surname										
Other Names										
Candidate Signature										

For Examiner's Use	
Examiner's Initials	
Question	Mark
1	
2	
3	
4	
TOTAL	



General Certificate of Education
Advanced Level Examination
June 2015

Physics A

PHYA5/2D

Unit 5D Turning Points in Physics Section B

Thursday 18 June 2015 9.00 am to 10.45 am

For this paper you must have:

- a calculator
- a pencil and a ruler
- a Data and Formulae Booklet (enclosed).

Time allowed

- The total time for both sections of this paper is 1 hour 45 minutes.
You are advised to spend approximately 50 minutes on this section.

Instructions

- Use black ink or black ball-point pen.
- Fill in the boxes at the top of this page.
- Answer **all** questions.
- You must answer the questions in the spaces provided. Do not write outside the box around each page or on blank pages.
- Do all rough work in this book. Cross through any work you do not want to be marked.
- Show all your working.

Information

- The marks for questions are shown in brackets.
- The maximum mark for this section is 35.
- You are expected to use a calculator where appropriate.
- A *Data and Formulae Booklet* is provided as a loose insert.
- You will be marked on your ability to:
 - use good English
 - organise information clearly
 - use specialist vocabulary where appropriate.



Section B

The maximum mark for this section is 35. You are advised to spend approximately 50 minutes on this section.

- 1** **Figure 1** shows part of an evacuated tube that is used to determine the specific charge (e/m) for an electron. An electron beam is directed between the two parallel metal plates, X and Y. In the region between the plates, a magnetic field is applied perpendicularly into the plane of the diagram. An electric field can be applied in this region by applying a potential difference (pd) between the plates.

Figure 1

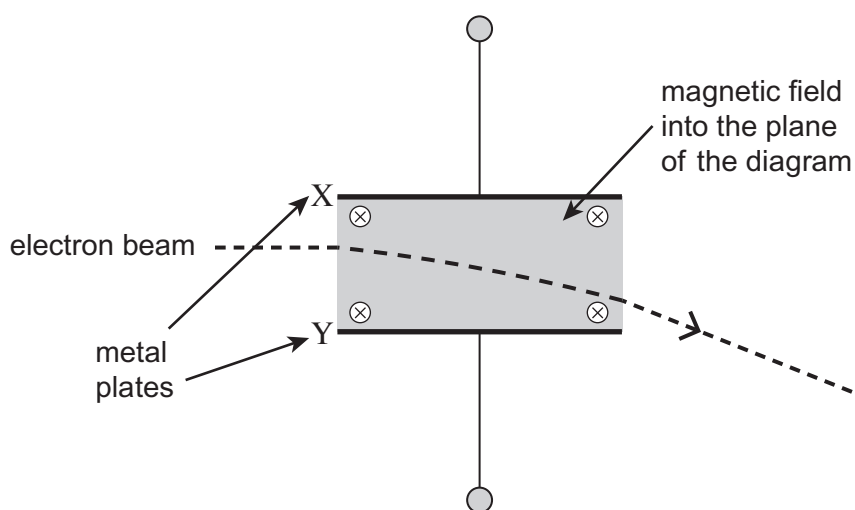

- 1 (a)** **Figure 1** shows the path of the electron beam when the magnetic field is applied and the pd between X and Y is zero.
- 1 (a) (i)** Explain why the path followed by the electron beam in the magnetic field is a circular arc. **[2 marks]**

.....

.....

.....

.....



1 (a) (ii) Show that the speed v of the electrons is given by $v = \frac{Ber}{m}$

where r is the radius of the path of an electron in the magnetic field and B is the flux density of the magnetic field.

[1 mark]

1 (a) (iii) A pd V is now applied between X and Y without changing the flux density of the magnetic field. V is adjusted until the electron beam is not deflected as it travels in the region between the plates.

Determine an expression for the speed v of the electrons in terms of V , B and the separation d of the metal plates.

[1 mark]

1 (b) Use the equation given in part (a)(ii) and your answer to part (a)(iii) to show that the specific charge for the electron = $\frac{V}{B^2 r d}$.

[1 mark]

Question 1 continues on the next page

Turn over ►



1 (c) If the charge on an electron is known then its mass can be determined from the specific charge. Describe how Millikan’s experiment with charged oil droplets enables the electronic charge to be determined.

Include in your answer:

- the procedures used to determine the radius of a droplet and the charge on a droplet
- how the measurements made are used
- how the electronic charge can be deduced.

[6 marks]

The quality of your written communication will be assessed in your answer.

.....

.....

.....

.....

.....

.....

.....

.....

.....

.....

.....

.....

.....

.....

.....

.....

.....

.....

.....

.....

.....

.....

.....



.....

.....

.....

.....

.....

.....

.....

.....

.....

.....

.....

.....

.....

.....

.....

.....

.....

.....

.....

11

Turn over ►



2 (a) (i) Describe how Newton used the corpuscular theory to explain the refraction of light as it passes from one substance into a substance of higher optical density.

[3 marks]

.....

.....

.....

.....

.....

.....

.....

2 (a) (ii) Huygens used a wave theory to explain refraction.

Explain why the corpuscular theory was rejected in favour of a wave theory to explain refraction.

[2 marks]

.....

.....

.....

.....

.....

.....



2 (a) (iii) Describe and explain the difference in the appearance of the fringes in Young's double-slit experiment that are predicted by the corpuscular theory and by the wave theory for light.

[2 marks]

.....

.....

.....

.....

.....

.....

2 (b) Electromagnetic waves and matter are now known to exhibit both particle and wave behaviour. The photons for a particular X-ray wavelength have energy 5.0 keV.

Calculate the potential difference through which an electron has to be accelerated so that its de Broglie wavelength is the same as that of this X-ray.

[4 marks]

11

Turn over ►



- 3 **Figure 2** shows the paths of light rays through a simplified version of the apparatus used by Michelson and Morley.

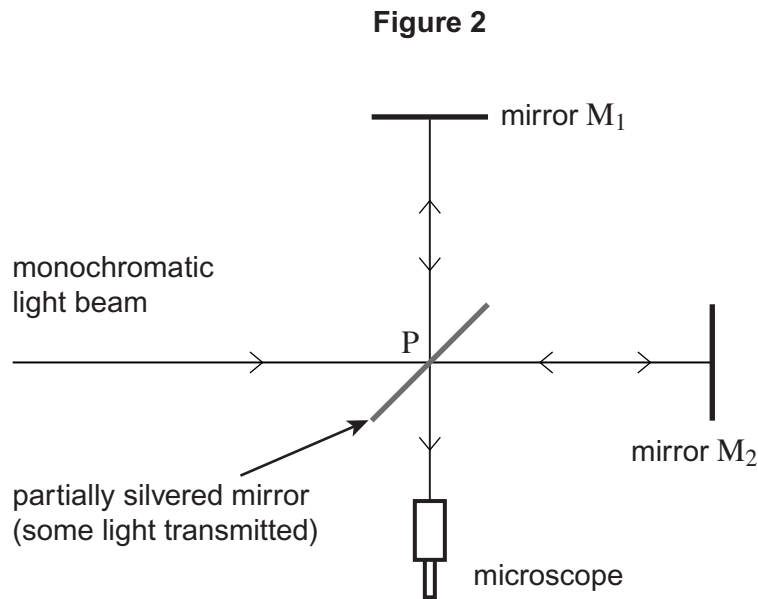

In the apparatus, light waves reflected by the mirrors M_1 and M_2 , meet at P so that they superpose and produce interference fringes. These are observed using the microscope.

Michelson and Morley predicted that the fringes would shift when the apparatus was rotated through 90° . They thought that this shift would enable them to measure the speed of the Earth through a substance, called the aether, that was thought to fill space.

- 3 (a) Explain why Michelson and Morley expected that the fringe positions would shift when the apparatus was rotated through 90° .

[2 marks]

.....

.....

.....

.....

.....

.....



3 (b) In their apparatus they made the distances PM_1 and PM_2 the same and equal to d . They used light of wavelength (λ) about 550 nm and knew that the speed of light c was $3.0 \times 10^8 \text{ m s}^{-1}$. Using known astronomical data, they calculated the speed v at which they thought the Earth moved through the aether. They were then able to predict that when the apparatus was rotated through 90° the fringes should shift by a distance $0.4f$, where f was the fringe spacing.

3 (b) (i) To determine v , Michelson and Morley assumed that the Sun was stationary with respect to the aether as the Earth moved through it. Suggest, using this assumption, how the speed v of the Earth through the aether could be determined. You do not need to do the calculation.

[1 mark]

.....

.....

.....

.....

3 (b) (ii) Michelson and Morley calculated v to be $3.0 \times 10^4 \text{ m s}^{-1}$. They worked out Δf , the magnitude of the expected shift of the fringes, using the formula $\Delta f = \frac{2v^2d}{c^2\lambda} f$.

Calculate the distance d they used in their experiment.

[1 mark]

$d = \dots\dots\dots \text{ m}$

Question 3 continues on the next page

Turn over ►



- 3 (c)** Although a shift of $0.4f$ was easily detectable, no shift was observed. Explain what this null result demonstrated and its significance for Einstein in his special theory of relativity. **[2 marks]**

.....

.....

.....

.....

.....

.....

6



4 A muon is an unstable particle produced by cosmic rays in the Earth's atmosphere. Muons that are produced at a height of 10.7 km above the Earth's surface, travel at a speed of $0.996c$ toward Earth, where c is the speed of light. In the frame of reference of the muons, the muons have a half-life of 1.60×10^{-6} s.

4 (a) (i) Calculate how many muons will reach the Earth's surface for every 1000 that are produced at a height of 10.7 km.

[3 marks]

number of muons

4 (a) (ii) Which of the following statements is correct? Tick (✓) the correct answer.

[1 mark]

	✓ if correct
For an observer in a laboratory on Earth, the distance travelled by a muon that reaches the Earth is greater than the distance travelled by a muon in its frame of reference	
For an observer in a laboratory on Earth, time passes more slowly than it does for a muon in its frame of reference	
For an observer in a laboratory on Earth, the probability of a muon decaying each second is lower than it is for a muon in its frame of reference	

Question 4 continues on the next page

Turn over ►



- 4 (b) (i) Show that the total energy of an electron that has been accelerated to a speed of $0.98c$ is about 4×10^{-13} J.

[2 marks]

- 4 (b) (ii) The total energy of an electron travelling at a speed of $0.97c$ is 3.37×10^{-13} J. Calculate the potential difference required to accelerate an electron from a speed of $0.97c$ to a speed of $0.98c$.

[1 mark]

potential difference = V

7

END OF QUESTIONS

