

Monday 23 November 2020 – Morning

GCSE (9–1) Physics B (Twenty First Century Science)

J259/02 Depth in physics (Foundation Tier)

Time allowed: 1 hour 45 minutes



You must have:

- a ruler (cm/mm)
- the Data Sheet for GCSE (9-1) Physics B (inside this document)

You can use:

- a scientific or graph calculator
- an HB pencil



Please write clearly in black ink. **Do not write in the barcodes.**

Centre number

Candidate number

First name(s) _____

Last name _____

INSTRUCTIONS

- Use black ink. You can use an HB pencil, but only for graphs and diagrams.
- Write your answer to each question in the space provided. If you need extra space use the lined pages at the end of this booklet. The question numbers must be clearly shown.
- Answer **all** the questions.
- Where appropriate, your answer should be supported with working. Marks might be given for using a correct method, even if your answer is wrong.

INFORMATION

- The total mark for this paper is **90**.
- The marks for each question are shown in brackets [].
- Quality of extended response will be assessed in questions marked with an asterisk (*).
- This document has **28** pages.

ADVICE

- Read each question carefully before you start your answer.

Answer **all** the questions.

1 Nina does an experiment to show the refraction of a ray of white light through a glass block.

(a) Which diagram, **A**, **B**, **C** or **D**, shows the correct path of the ray of white light through the glass block?

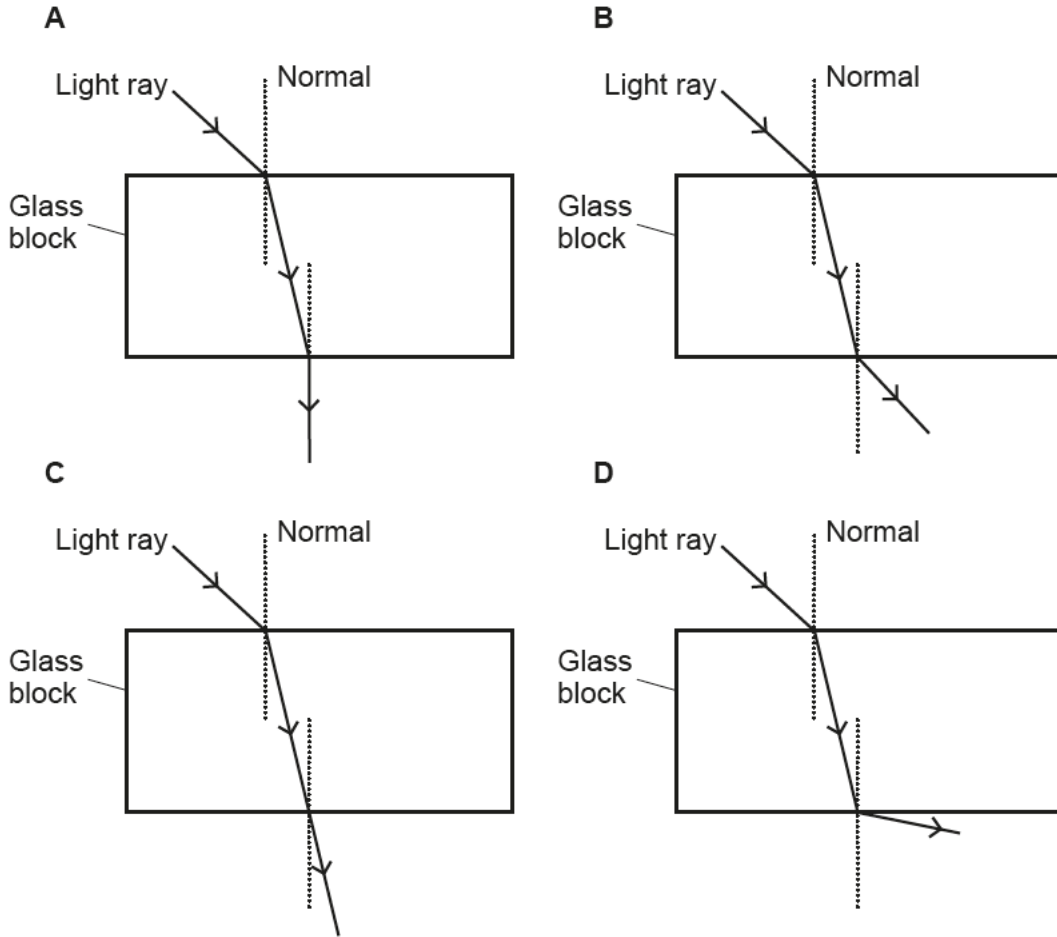

Tick (✓) **one** box.

- A
- B
- C
- D

[1]

- (b) Nina then shines the ray of white light through a triangular prism, and observes that the white light spreads out into a band of colours, as shown in Fig. 1.1.

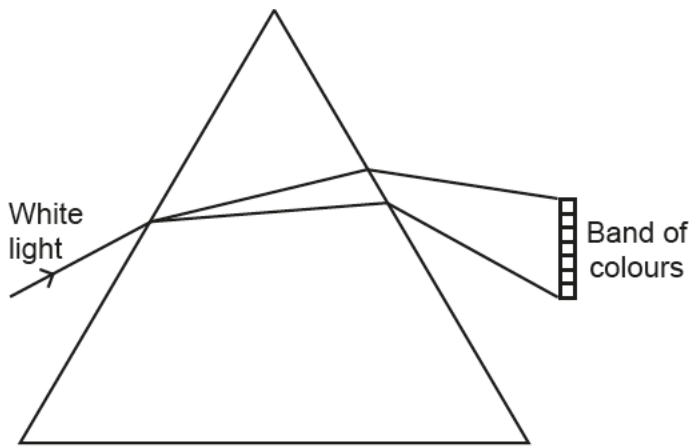

Fig. 1.1

What is the correct scientific name for the **band** of colours?

Put a **ring** around the correct answer.

- Dispersion** **Rainbow** **Reflection** **Spectrum** [1]

- (c) When white light passes through the prism, the different colours of white light refract by different amounts, which forms the band of colours shown in Fig. 1.1.

- (i) Which colour of white light refracts the most?

Tick (✓) **one** box.

- | | |
|--------|--------------------------|
| Red | <input type="checkbox"/> |
| Green | <input type="checkbox"/> |
| Violet | <input type="checkbox"/> |
| Yellow | <input type="checkbox"/> |

[1]

- (ii) Which colour of white light refracts the least?

Tick (✓) **one** box.

- | | |
|--------|--------------------------|
| Red | <input type="checkbox"/> |
| Green | <input type="checkbox"/> |
| Violet | <input type="checkbox"/> |
| Yellow | <input type="checkbox"/> |

[1]

- (iii) Why do the different colours of white light refract by different amounts in Fig. 1.1?

.....

[1]

- 2 Jamal does an investigation to see how two bar magnets behave when they are brought close to each other.

Fig. 2.1 shows how the two bar magnets are arranged.

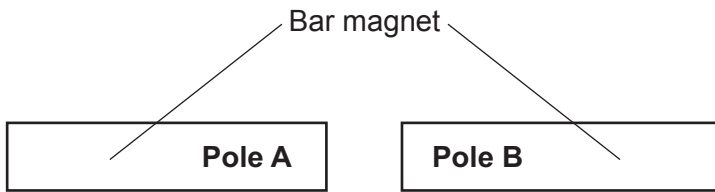

Fig. 2.1

- (a) The table shows the possible positions of the north and south poles for the two bar magnets.

Complete the table to show the expected results for the investigation.

Use words from the list.

You may use each word once, more than once or not at all.

Attract **No effect** **Repel**

The first one has been done for you.

Pole A	Pole B	Expected Result
N	S	Attract
N	N
S	S
S	N

[2]

(b) Fig. 2.2 shows the magnetic field around a bar magnet.

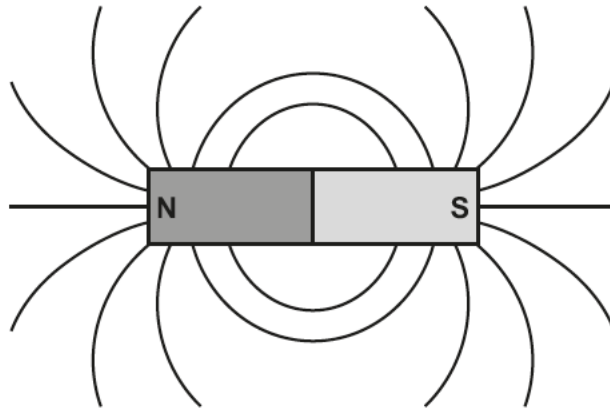

Fig. 2.2

(i) Draw **four** arrows on Fig. 2.2 to show the direction of the magnetic field around the bar magnet. [1]

(ii) Complete the sentence about Jamal's observations.

Use words from the list.

You can use each word once, more than once, or not at all.

stronger **weaker** **closer together** **further apart**

Jamal observes that when the two bar magnets are attracted to one another, the magnetic force of attraction near the poles is, because this is where the magnetic field lines are

[2]

(c) Which statement about magnetism is correct?

Tick (✓) **one** box.

An induced magnet loses its magnetism when removed from a magnetic field.

A permanent magnet loses its magnetism when removed from a magnetic field.

Induced magnets produce their own magnetic field.

Permanent magnets do **not** produce their own magnetic field.

[1]

3 Beth is a skydiver. Skydivers freefall before opening a parachute.

(a) (i) After falling for a small period of time, balanced forces act on Beth.

Describe Beth's movement when these balanced forces act.

.....
..... [1]

(ii) Draw **two** labelled arrows on the diagram to identify these balanced forces acting on Beth.



[2]

(b) Beth has a mass of 60 kg.

Calculate Beth's weight.

Use the equation: weight = mass × gravitational field strength

Gravitational field strength = 10 N/kg

Weight = N [2]

(c) Mass is a scalar quantity. Weight is a vector quantity.

(i) Give **one** other example of a vector quantity.

..... [1]

(ii) What is the difference between a vector quantity and a scalar quantity?

.....
..... [1]

7
BLANK PAGE

PLEASE DO NOT WRITE ON THIS PAGE

- 4 Li does an experiment to find the spring constant of a spring.

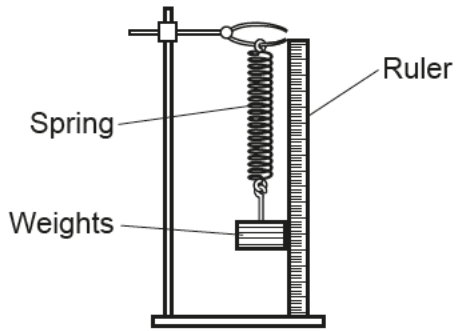

Li measures the extension of the spring when different weights are added, and records the results in the table.

Weight (N)	Extension (cm)
0	0
1.0	1.5
2.0	3.0
3.0	4.5
4.0	6.0
5.0	7.5

- (a) (i) Plot the remaining **two** points on Fig. 4.1 and draw a line of best fit.

[2]

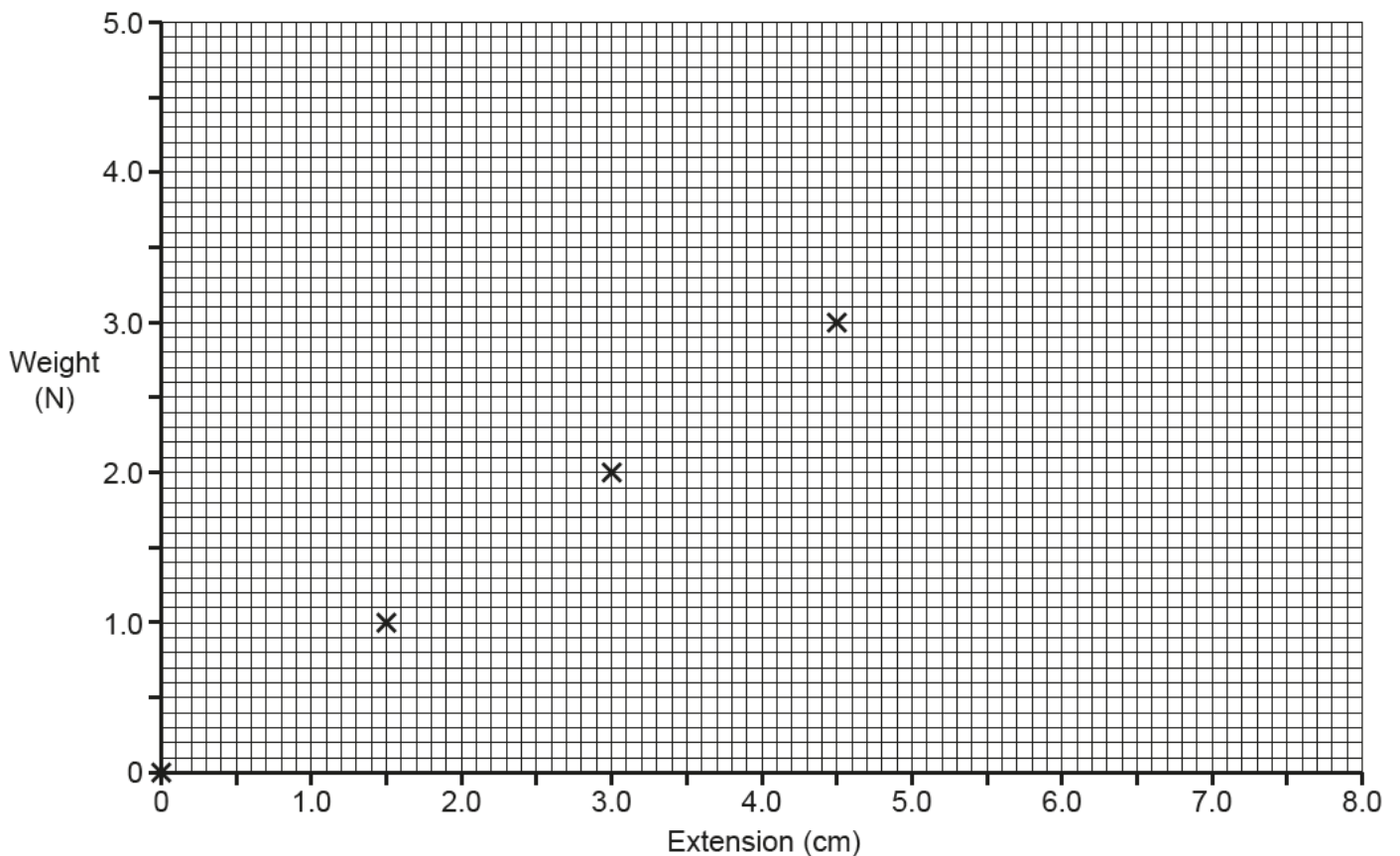

Fig. 4.1

(ii) Describe the relationship between weight and the extension of the spring.

.....
 [1]

(iii) Calculate the spring constant of the spring.

Show your working on **Fig. 4.1**.

Use the equation: spring constant = force ÷ extension

Give your answer to **2** significant figures.

Spring constant = N/cm [3]

(b) **Fig. 4.2** shows Li's results for another elastic material.

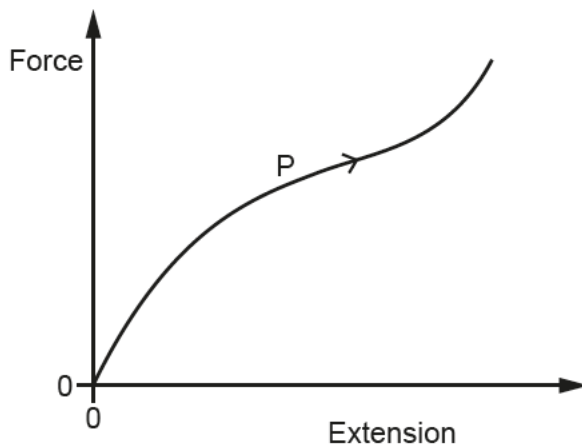

Fig. 4.2

Complete the following statements about **Fig. 4.2**.

Put a **(ring)** around the correct choices.

The relationship for the elastic material is **linear** / **non-linear**.

The elastic material could be a **rubber band** / **metal wire**.

[2]

- 5 Nuclear Physicists use atomic numbers and mass numbers to identify isotopes.

The table shows data on three atoms, **Atom A**, **Atom B**, and **Atom C**.

	Atom A	Atom B	Atom C
Atomic number	6	6
Mass number	12	14	14
Number of neutrons	8	7
Stable	Yes	No	Yes

- (a) Complete the **two** missing values in the table. [1]

- (b) Isotopes of an element are atoms with the same number of protons but a different number of neutrons.

Which **two** atoms are isotopes of the same element?

Put a (ring) around the **two** correct answers.

Atom A

Atom B

Atom C

[1]

- (c) Carbon-14 is an unstable isotope which decays to nitrogen-14.



What is the decay particle emitted when carbon-14 decays?

Put a (ring) around the correct answer.

Alpha particle

Beta particle

Gamma ray

Neutron

[1]

- 6 Amaya builds an electrical circuit to investigate the relationship between current and potential difference for a fixed resistor.

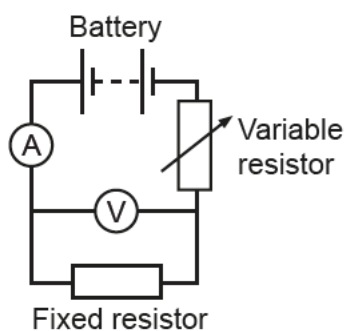

Fig. 6.1 shows Amaya's results for the fixed resistor.

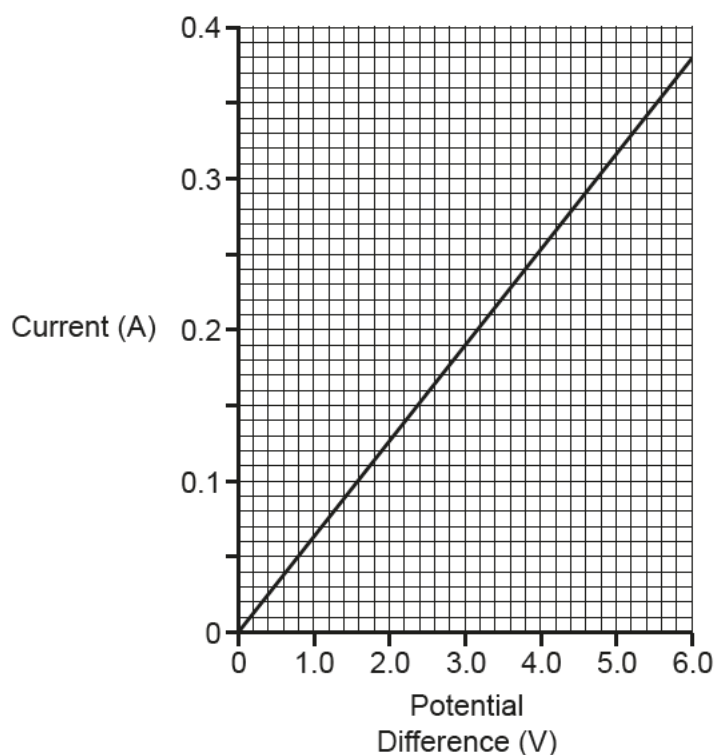

Fig. 6.1

- (a) Calculate the resistance of the fixed resistor.

Use the equation: resistance = potential difference \div current

Show your working on Fig. 6.1.

Give your answer to 1 decimal place and the **unit** for resistance.

Resistance = Unit [4]

Turn over

- (b) Amaya repeats the investigation, but replaces the fixed resistor with a filament lamp. Her results are shown in **Fig. 6.2**.

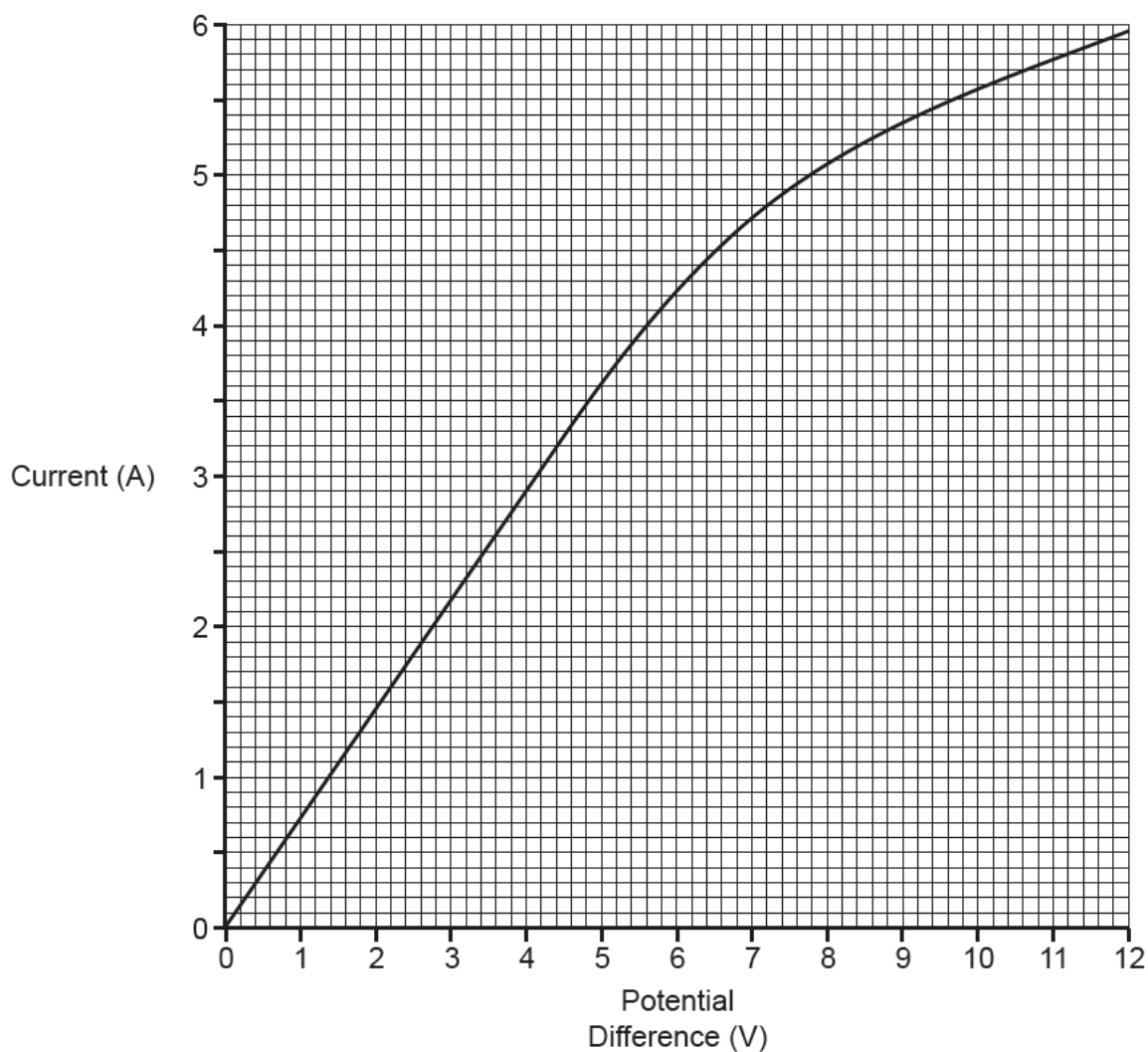

Fig. 6.2

Amaya says:

Fig. 6.2 shows that as the potential difference in the circuit increases, the resistance of the lamp increases.



Discuss Amaya's comments.

Use **Fig. 6.2** to support your answer.

.....

.....

.....

.....

.....

.....

.....

8 The diagrams show a model for the arrangement of particles in three states of matter.

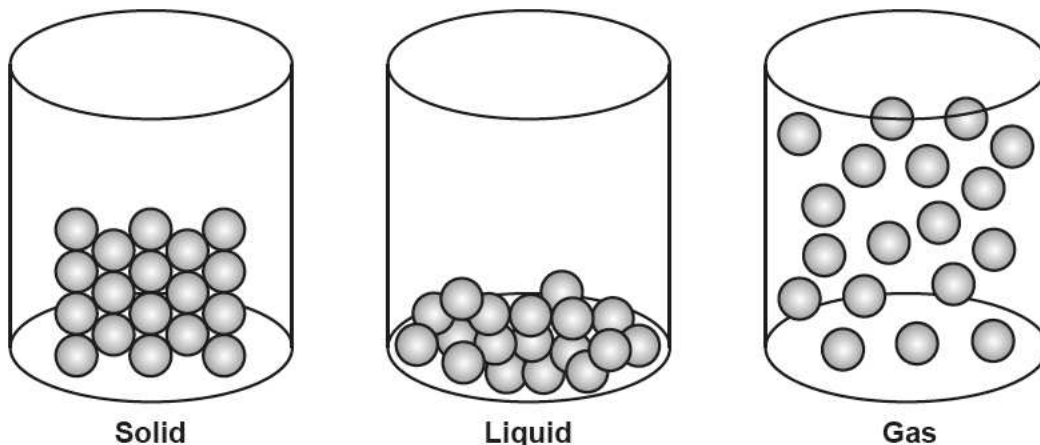

(a) Complete the following statements about the three states of matter.

Use words from the list.

You may use each word once, more than once, or not at all.

condensation evaporation freezing melting sublimation

The physical change from a gas to a liquid is called

The physical change from a solid to a gas is called

The physical change from a liquid to a gas is called [3]

(b) Explain why the density of ice is higher than the density of water vapour.

Use ideas from the particle model, and the diagrams to support your answer.

.....

.....

.....

..... [2]

9 Layla took a bus journey to a town 16 km away.

The distance–time graph shows her bus journey.

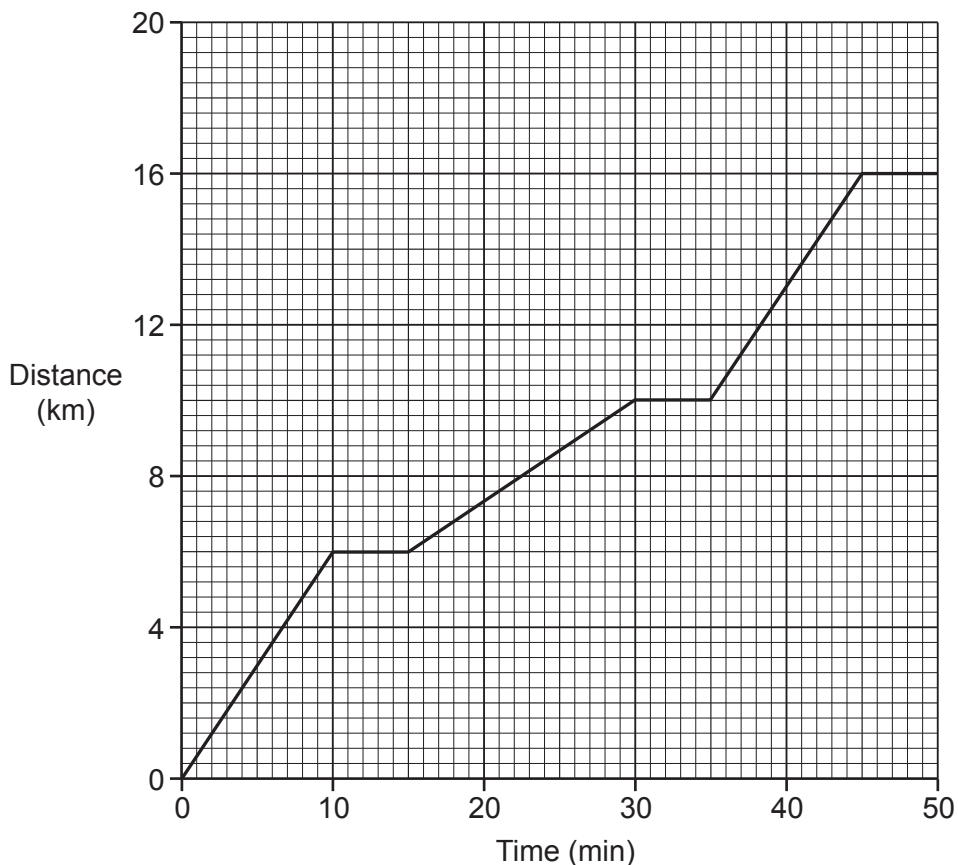

(a) (i) How many times during the journey was the bus stationary?

..... [1]

(ii) How does the graph show that the bus was slower between 15–30 minutes than 35–45 minutes?

..... [1]

(b) Calculate the average speed of the bus between 35 and 45 minutes.

Use the equation: distance = speed × time

Show your working on the graph.

Average speed = km/min [2]

10 Kai wants to buy solar panels for his house.

A local solar panel company has provided him with **data** on the amount of energy he can **expect** to generate per month from a 4 kW solar panel system, based on average sunshine over the last 30 years.

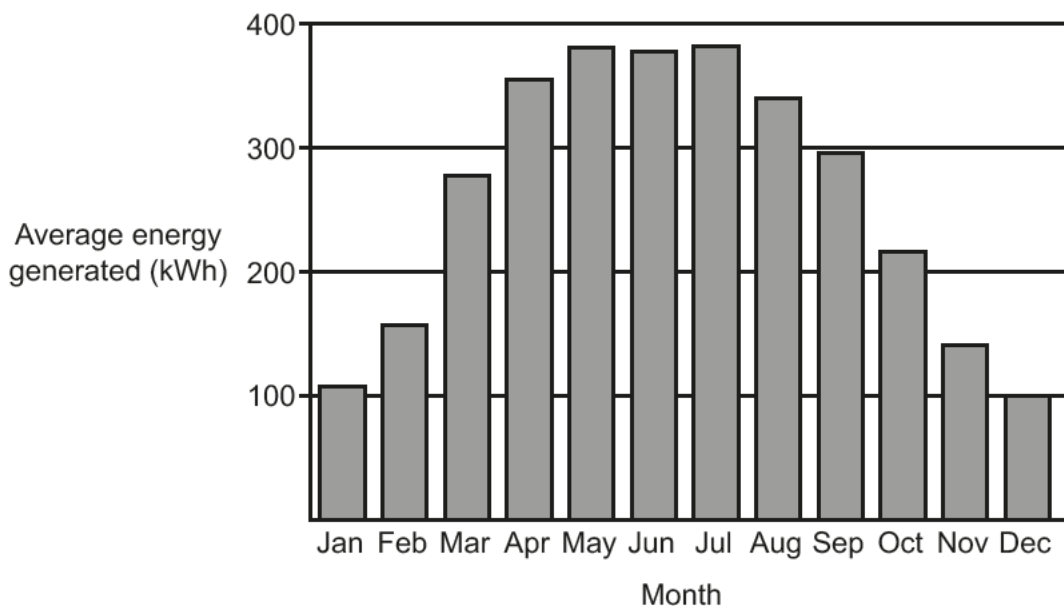

Kai's friend Amir has owned solar panels for a year, and has recorded the energy his 4 kW solar panel system has generated over twelve months, as shown in the table.

Month	Energy generated (kWh)
January	150
February	160
March	170
April	210
May	350
June	400
July	300
August	380
September	360
October	180
November	160
December	40

(a) (i) Give **one** similarity and **one** difference between the data from the local solar panel company, and Amir's data.

Similarity

.....

Difference

..... [2]

(ii) Give **two** reasons why there is greater uncertainty in Amir's data than the local solar panel company's data.

1.
.....
2.
.....

[2]

(b) Kai requires a system that will deliver a minimum power of 3800 W to his house.

He must also buy storage batteries to provide electricity when solar or wind power is not available. These cost £250.

	One wind turbine	One solar panel
Maximum power output (W)	1250	350
Voltage (V)	12	12
Cost (£) per item	1500	415

(i) Calculate the total cost to deliver a minimum power of **3800 W** to his house, using **solar panels**.

Total cost = £ [3]

(ii) Kai has £5000 to spend.

Which system should Kai use to deliver a minimum power of 3800 W to his house?

Wind turbines

Solar panels

Explain your answer.

-

[2]

- 11 Water is used as a coolant in heating systems because it has a high specific heat capacity.

Nina does an experiment to find the specific heat capacity of water, by heating 1 kg of water in a 2.4 kW kettle.

The kettle takes several minutes to heat the water to its boiling point.

Nina

I can use a balance to accurately measure the 1 kg mass of water in the kettle.



- (a) State **two** other pieces of equipment that Nina needs to use in her experiment.

1.

2.

[2]

- (b) The 2.4 kW kettle takes 3 minutes to heat the water from room temperature to boiling point.

Calculate the total energy supplied by the kettle.

Use the equation: energy = power \times time

Energy = J [4]

(c) The useful energy transferred to heat the water from room temperature (20 °C) to boiling point, 100 °C is 345 600 J.

(i) Calculate the efficiency of the kettle.

Use your answer to (b).

Use the equation: efficiency = useful energy transferred ÷ total energy transferred

Efficiency = [2]

(ii) Calculate the specific heat capacity of the water from Nina’s experiment.

Use the equation:

change in internal energy = mass × specific heat capacity × change in temperature

Specific heat capacity = J/kg °C [2]

(d) (i) Suggest why the energy **supplied** by the 2.4kW kettle is more than the energy **transferred** to the 1 kg of water.

..... [1]

(ii) Suggest **one** way in which the experiment to find the specific heat capacity of water could be improved.

..... [1]

12 James is an astronomer and he observes light from distant galaxies on Earth.

The diagram shows the spectral lines of hydrogen in the visible part of the electromagnetic spectrum, as seen on Earth, and for two galaxies at different distances away from Earth.

OCR is aware that third party material appeared in this exam but it has not been possible to identify and acknowledge the source. Item removed due to third party copyright restrictions.

(a) James makes a conclusion from this data.

Complete the sentences to finish James’s conclusion.

Use words from the list.

You can use each word once, more than once, or not at all.

- further** **nearer** **more** **less** **red** **blue**
- wavelength** **frequency** **faster** **slower**

The away the galaxies are from Earth, the
the spectral lines are shifted towards the end of the spectrum.

This suggests that the of the light coming from galaxies further away
is stretched. I can conclude that more distant galaxies must be moving away from the
Earth, than galaxies that are closer to Earth, which suggests
that the universe is expanding.

[4]

(b) James discovers a new galaxy and writes an article about it in a scientific journal.

Before it is published it must be peer reviewed.

Explain why and how the article is **peer reviewed**.

Why

How [2]

- 13 Electricity is transferred from power stations to consumers by the National Grid, as shown in Fig. 13.1.

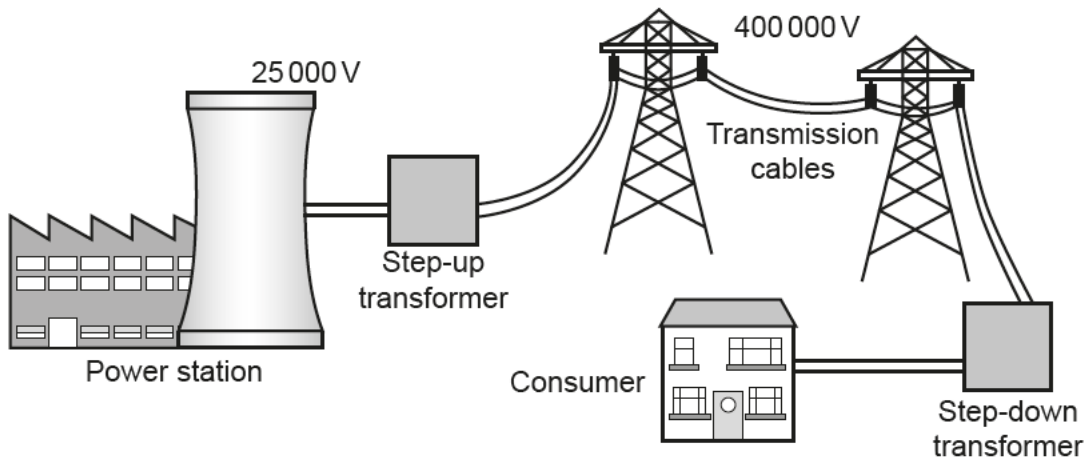

Fig. 13.1

- (a) The National Grid uses a step-up transformer to increase the potential difference from 25 000 V to 400 000 V before the current is sent along the transmission cables.

The current in the primary coil of the step-up transformer is 2000 A.

Calculate the current flowing in the secondary coil of the step-up transformer.

Use the Data Sheet.

Current = A [3]

(b) Fig. 13.2 shows the UK's demand for electricity during a 24 hour period, and the base load.

The base load is the amount of electricity which is constantly generated.

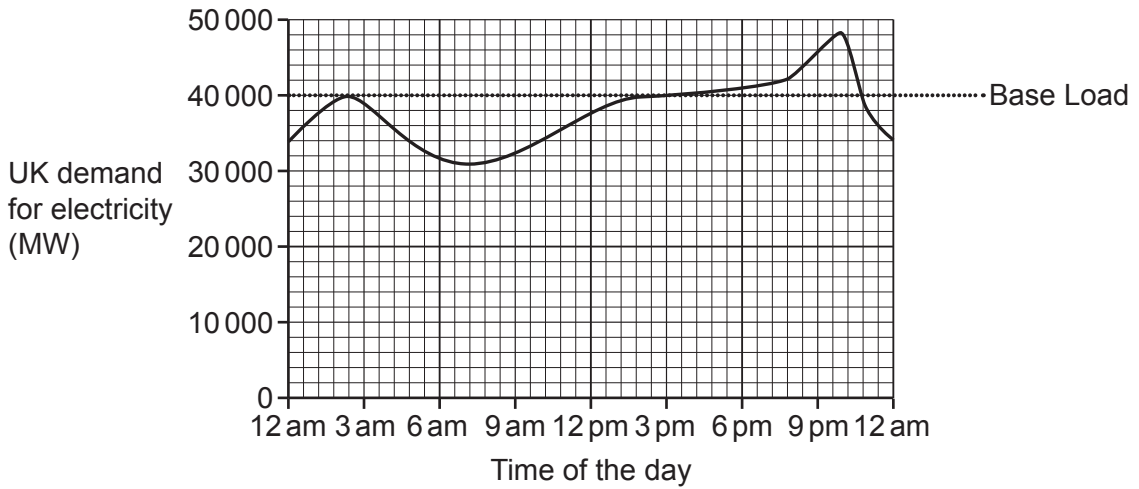

Fig. 13.2

(i) What is the value of the base load?

..... MW [1]

(ii) At which approximate time of the day is the demand for electricity the greatest?

..... [1]

(iii) At which approximate time of the day does the demand for electricity become greater than the base load?

Put a **ring** around the correct answer.

2.30am 7am 4pm 10.30pm

[1]

ADDITIONAL ANSWER SPACE

If additional space is required, you should use the following lined page(s). The question number(s) must be clearly shown in the margin(s).

A large rectangular area with a solid vertical line on the left side and horizontal dotted lines extending across the page, providing space for writing answers.

A grid for data entry consisting of 25 rows and 2 columns. The first column is defined by a solid vertical line on the left side. The second column is defined by a dotted vertical line on the right side. Each row is bounded by dotted horizontal lines at the top and bottom.

26
BLANK PAGE

PLEASE DO NOT WRITE ON THIS PAGE

BLANK PAGE

PLEASE DO NOT WRITE ON THIS PAGE

PLEASE DO NOT WRITE ON THIS PAGE

OCR

Oxford Cambridge and RSA

Copyright Information

OCR is committed to seeking permission to reproduce all third-party content that it uses in its assessment materials. OCR has attempted to identify and contact all copyright holders whose work is used in this paper to avoid the issue of disclosure of answer-related information to candidates. All copyright acknowledgements are reproduced in the OCR Copyright Acknowledgements Booklet, which is produced for each series of examinations and is freely available to download from our public website (www.ocr.org.uk) after the live examination series.

OCR has unwittingly failed to correctly acknowledge or clear any third-party content in this assessment material. OCR will be happy to correct its mistake at the earliest possible opportunity.

For queries or further information please contact the OCR Copyright Team, The Triangle Building, Shaftesbury Road, Cambridge CB2 8EA.

OCR is part of the Cambridge Assessment Group. Cambridge Assessment is the brand name of University of Cambridge Local Examinations Syndicate (UCLES), which is itself a department of the University of Cambridge.