

Thursday 05 November 2020 – Morning

GCSE (9–1) Mathematics

J560/05 Paper 5 (Higher Tier)

Time allowed: 1 hour 30 minutes



You can use:

- geometrical instruments
- tracing paper

Do not use:

- a calculator



Please write clearly in black ink. **Do not write in the barcodes.**

Centre number

--	--	--	--	--

Candidate number

--	--	--	--

First name(s)

Last name

INSTRUCTIONS

- Use black ink. You can use an HB pencil, but only for graphs and diagrams.
- Write your answer to each question in the space provided. If you need extra space use the lined pages at the end of this booklet. The question numbers must be clearly shown.
- Answer **all** the questions.
- Where appropriate, your answer should be supported with working. Marks might be given for using a correct method, even if your answer is wrong.

INFORMATION

- The total mark for this paper is **100**.
- The marks for each question are shown in brackets [].
- This document has **20** pages.

ADVICE

- Read each question carefully before you start your answer.

Answer **all** the questions.

1 Write 75 as a product of its prime factors.

..... [2]

2 (a) Solve.

$$4x + 3 = 13$$

(a) $x =$ [2]

(b) Multiply out and simplify.

$$5(2x + 3) + 2(x - 4)$$

(b) [3]

3 (a) The ratio 45 minutes to 3 hours 45 minutes can be written in the form $1 : n$.

Find the value of n .

(a) $n = \dots\dots\dots$ [2]

(b) Reece and Sarah share some money in the ratio $9 : 16$.

Reece says that Sarah gets more than 60% of this money.

Show that Reece is correct.

..... [3]

4 Dora has the following number cards.



She takes a card at random, replaces the card and then takes a second card. She adds the numbers on the two cards she has taken and records the total.

(a) Complete the following table to show all of her possible totals.

		First card				
		2	2	3	5	6
Second card	Total	2	2	3	5	6
	2	4	4	5	7	8
	2	4	4	5		8
	3	5	5		8	9
	5	7		8	10	11
6	8	8	9	11	12	

[1]

(b) Find the probability that her total is

(i) an even number,

(b)(i) [2]

(ii) a multiple of 3 or 4.

(ii) [2]

5

5 Charlie and Jasmine share cartons of apple juice.

Charlie drinks $\frac{1}{3}$ of a carton every day.

Jasmine drinks $\frac{2}{5}$ of a carton every day.

Any apple juice left in a carton at the end of the day is used the following day.

The cost of a carton is 70p.

Charlie and Jasmine buy just enough cartons to last them for 10 days.

How much do they spend in total for these cartons?

Give your answer in £.

Show your working.

£ [6]

- 6 A clock chimes every 20 minutes.
A light flashes every 8 minutes.
The clock chimes and the light flashes together at 08:00.

How many times between 08:01 and 12:30 will the clock chime and the light flash together?
Show your working.

..... [5]

- 7 A pattern is made from four congruent right-angled triangles.

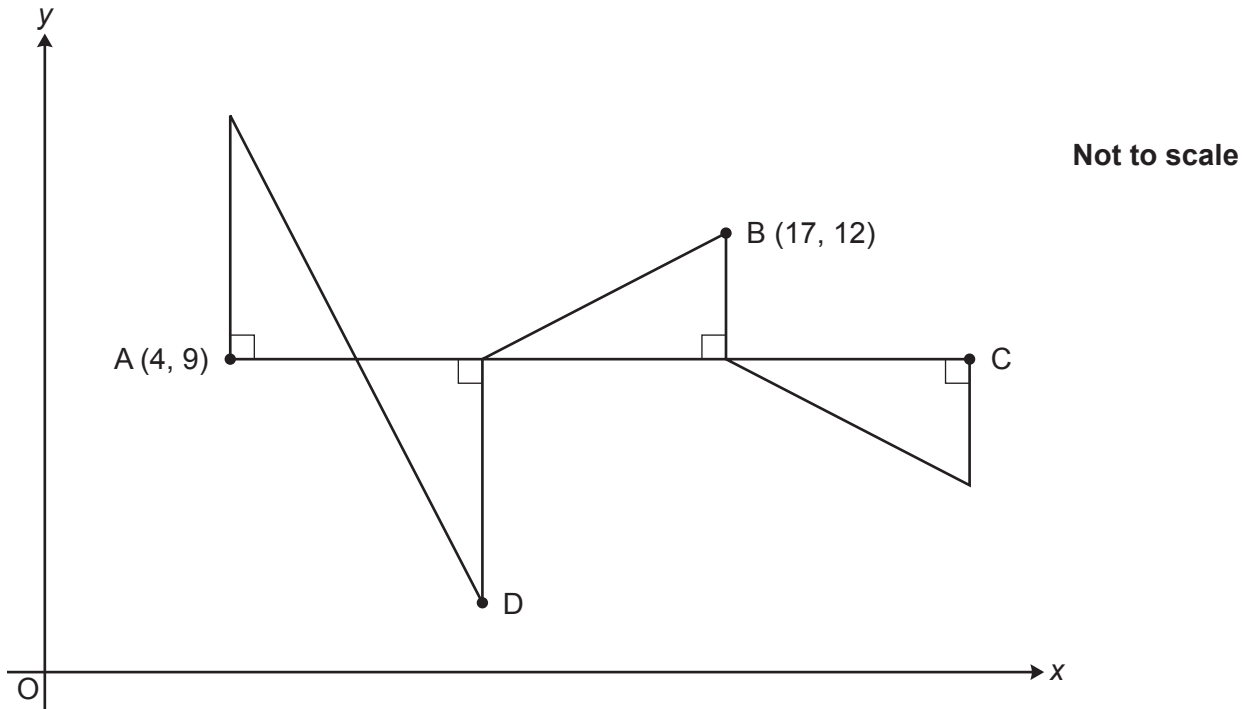

The line AC is parallel to the x -axis.

The point A has coordinates (4, 9) and the point B has coordinates (17, 12).

Work out the coordinates of point C and point D.

C (..... ,))

D (..... ,) [5]

8 A weather forecast says

- the probability that it will rain on Monday is 0.55
- and
- the probability that it will rain on Tuesday is 0.25.

Ella draws a tree diagram to show this information.

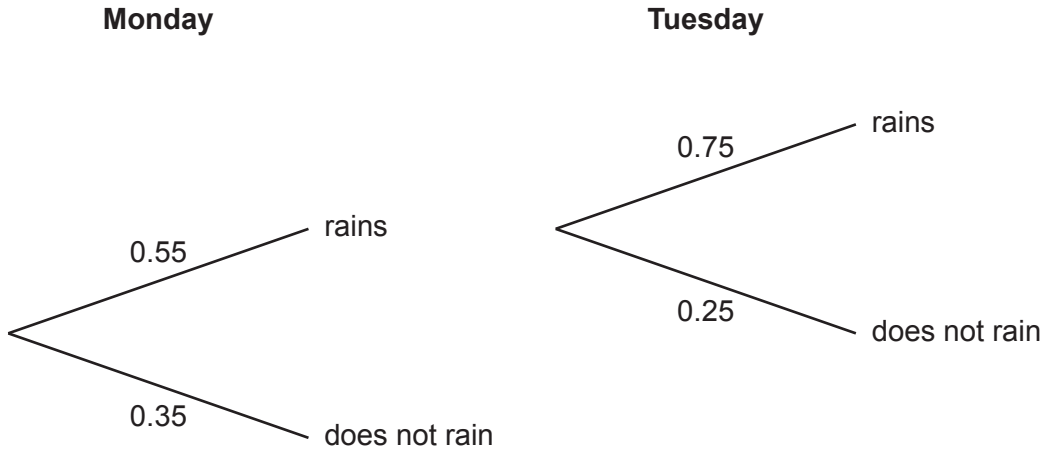

Write down three errors that Ella has made with her tree diagram.

1

.....

2

.....

3

..... [3]

- 9 In the diagram, AB and DC are parallel lines of equal length.

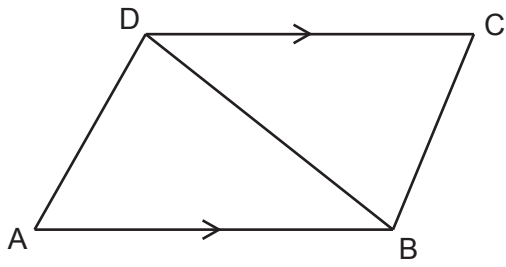

Not to scale

Prove that angle DAB = angle BCD.

.....

.....

.....

.....

..... [4]

10 Each day, Eve records how long it takes her to complete a puzzle.

On Friday, she took 50% less time than on Thursday.

On Saturday, she took 20% less time than on Friday.

On Saturday, she takes 36 minutes to complete the puzzle.

How many minutes did she take to complete the puzzle on Thursday?

Show your working.

..... minutes [5]

11 (a) Work out.

$$16^{-\frac{1}{2}}$$

(a) [2]

(b) Simplify.

$$\sqrt{6} \times \sqrt{3}$$

(b) [2]

- 12 The price, £ P , of a car is £20 000 in 2019.
The price is expected to decrease by 5% each year after 2019.

(a) Jasmine says

This means the price in 2021 is expected to be £18 000.

She is incorrect.

Explain her error and work out the correct answer.

Her error is

.....

The correct answer is £ [4]

- (b) (i) Write a formula for P in terms of n , where n is the number of years after 2019.

(b)(i) $P = \dots\dots\dots$ [2]

- (ii) Circle the graph that best represents the price, £ P , of the car n years after 2019.

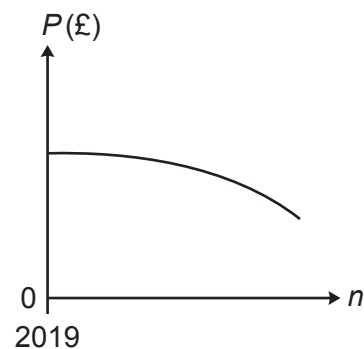
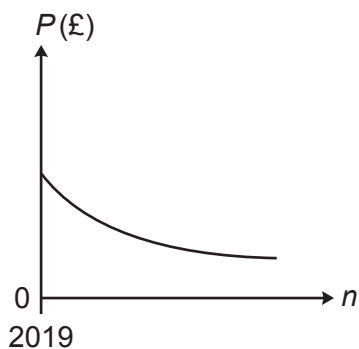
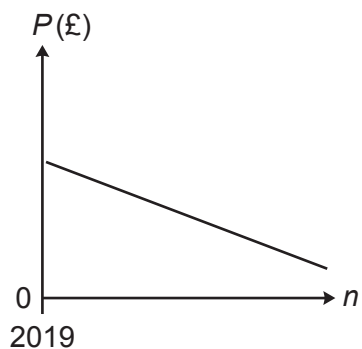

[1]

Turn over

13 (a) Sketch the graph of $y = \sin x$ for $0^\circ \leq x \leq 360^\circ$.

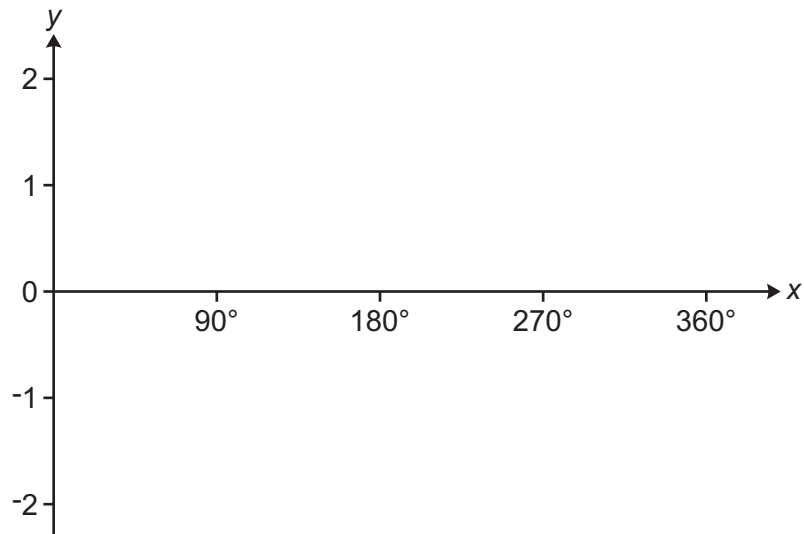

[2]

(b) The graph of $y = \cos(x - 30)$ for $0^\circ \leq x \leq 360^\circ$ crosses the x -axis in two places.

Write down the values of x where this occurs.

$x = \dots\dots\dots$ and $\dots\dots\dots$ [2]

14 Simplify.

(a) $4a^{\frac{1}{2}} \times 3a^2$

(b) $\left(\frac{2a^2}{a^{-3}}\right)^3$

(a) [2]

(b) [3]

15 Solve.

$$\frac{x}{x+6} = 5$$

$x =$ [3]

16 (a) The masses, m kg, of some parcels are shown below.

4 15 14 11 12 3 1 18 13 2 16 10

Jack constructs this grouped frequency table to record the masses.

Mass (m kg)	Tally	Frequency
$0 \leq m \leq 5$		
$5 \leq m \leq 10$		
$10 \leq m \leq 15$		
$15 \leq m \leq 20$		

Explain why Jack's table is unsuitable to record the masses.

.....
 [1]

(b) The histogram summarises the times taken, in minutes, by some students to complete a race.

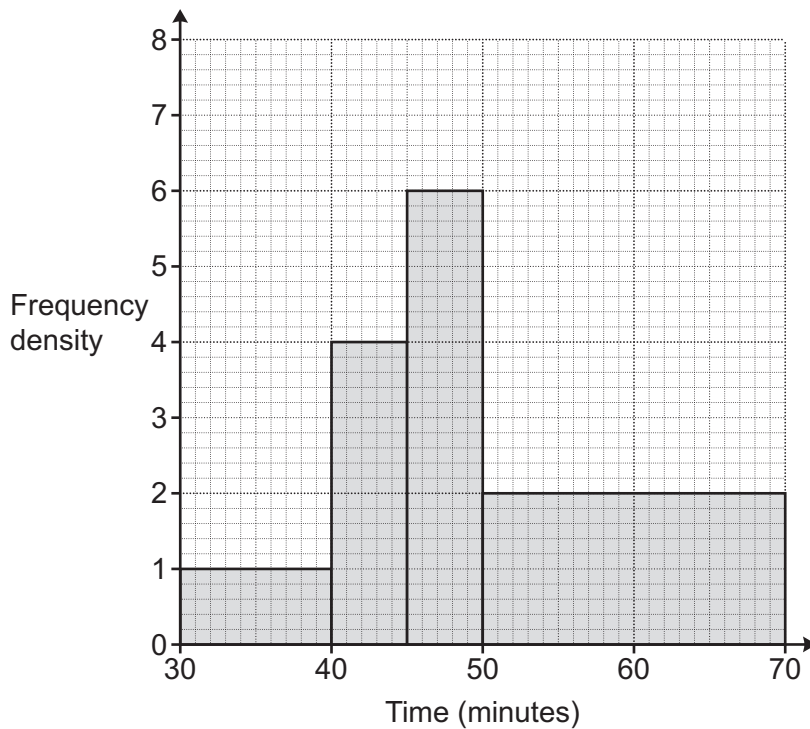

(i) Show that 70 students took between 45 and 70 minutes to complete the race. [2]

(ii) Calculate an estimate of the mean time taken to complete the race.
Show your working.

(b)(ii)min [5]

17 The graphs of $y = x$ and $y = -2$ are drawn on the grid.

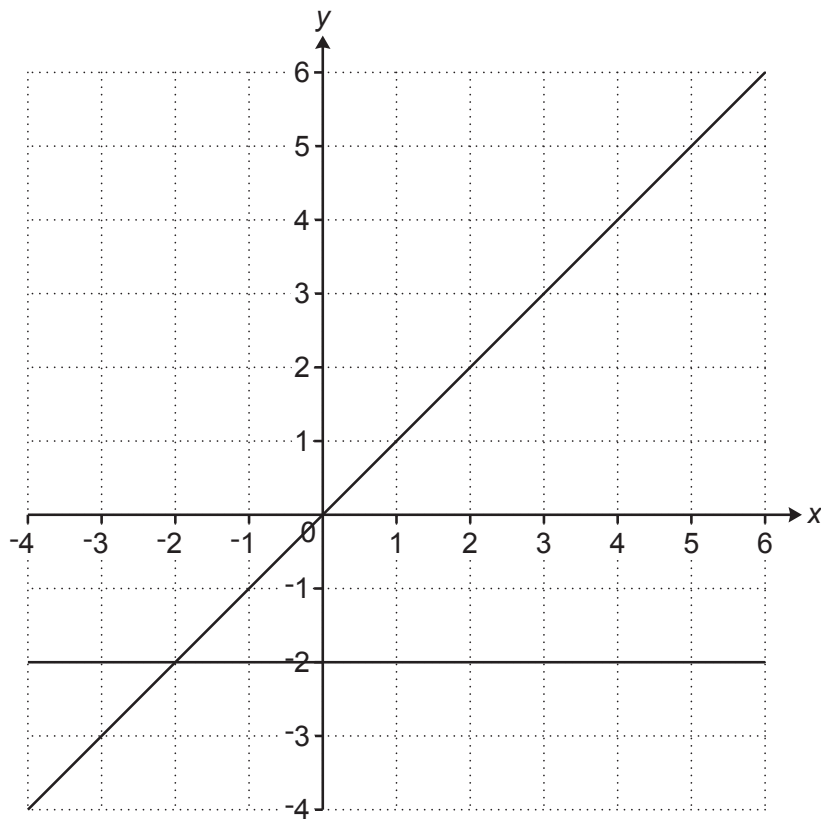

The region R satisfies the following inequalities.

$$y \geq -2 \quad y \leq x \quad y < 4 - 2x$$

By drawing one more line, find and label the region R.

[5]

18 The diagram shows a triangular field PQR which is used to grow organic carrots.

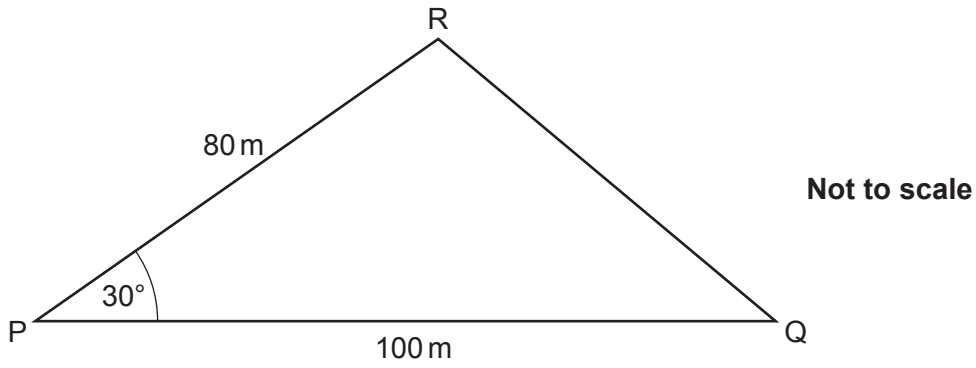

PQ = 100 m, PR = 80 m and angle RPQ = 30°.

In recent years, an average of 2.5 kg of carrots has been harvested from each square metre of the field.

(a) Use this information to work out the total mass of carrots that might have been harvested from the field in 2019.

(a)kg [4]

(b) Why might the answer to part (a) be unreliable?

.....
 [1]

19 (a) Write $x^2 - 10x + 22$ in the form $(x - a)^2 - b$.

(a) [3]

(b) Sketch the graph of $y = x^2 - 10x + 22$.
Show clearly the coordinates of any turning points and the value of the y -intercept.

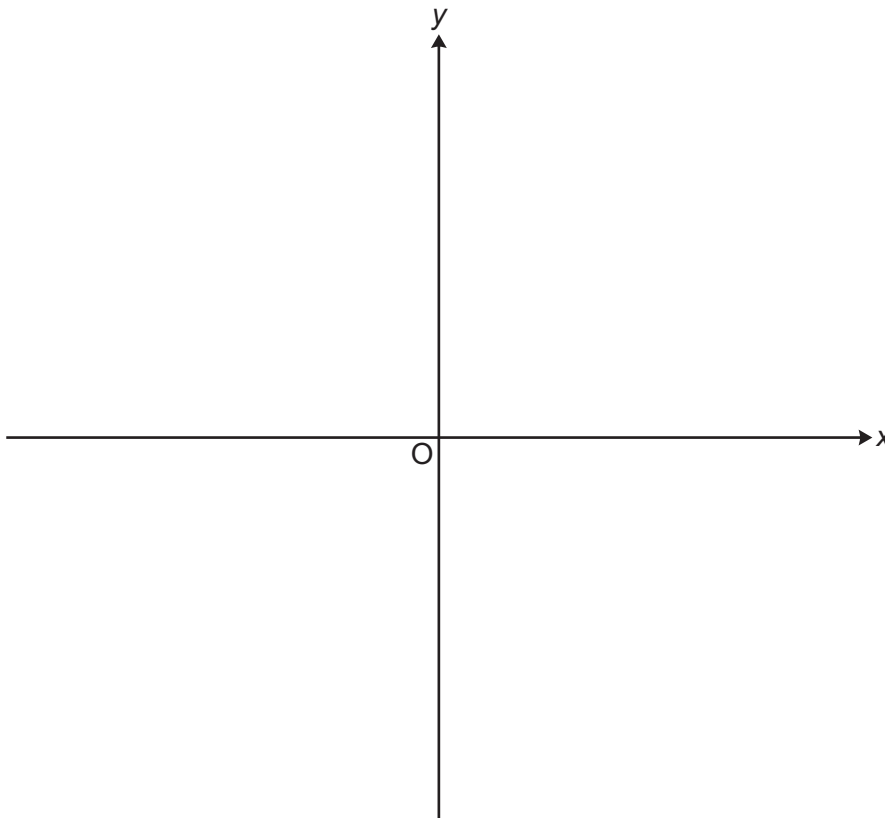

[4]

20 ABCD is a trapezium.

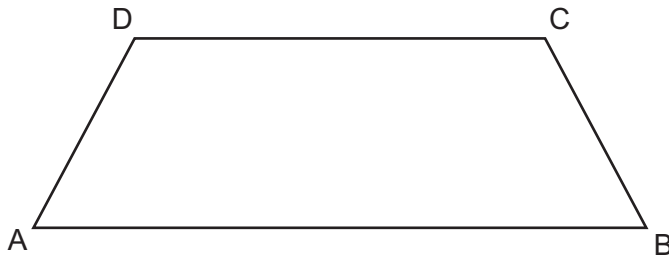

Not to scale

The perimeter of the trapezium is 56 cm.
The ratio $AD : AB : DC : BC = 5 : 12 : 6 : 5$.

Calculate the area of the trapezium.
Show your working.

..... cm² [7]

END OF QUESTION PAPER

ADDITIONAL ANSWER SPACE

If additional space is required, you should use the following lined page(s). The question number(s) must be clearly shown in the margin(s).

A large rectangular area with a solid vertical line on the left side and horizontal dotted lines across the rest of the page, providing space for writing answers.



Copyright Information

OCR is committed to seeking permission to reproduce all third-party content that it uses in its assessment materials. OCR has attempted to identify and contact all copyright holders whose work is used in this paper. To avoid the issue of disclosure of answer-related information to candidates, all copyright acknowledgements are reproduced in the OCR Copyright Acknowledgements Booklet. This is produced for each series of examinations and is freely available to download from our public website (www.ocr.org.uk) after the live examination series. If OCR has unwittingly failed to correctly acknowledge or clear any third-party content in this assessment material, OCR will be happy to correct its mistake at the earliest possible opportunity.

For queries or further information please contact The OCR Copyright Team, The Triangle Building, Shaftesbury Road, Cambridge CB2 8EA.

OCR is part of the Cambridge Assessment Group; Cambridge Assessment is the brand name of University of Cambridge Local Examinations Syndicate (UCLES), which is itself a department of the University of Cambridge.