

Thursday 9 June 2016 – Morning

GCSE MATHEMATICS A

A503/02 Unit C (Higher Tier)

Candidates answer on the Question Paper.

OCR supplied materials:
None

- Other materials required:**
- Scientific or graphical calculator
 - Geometrical instruments
 - Tracing paper (optional)

Duration: 2 hours



Candidate forename		Candidate surname	
--------------------	--	-------------------	--

Centre number						Candidate number				
---------------	--	--	--	--	--	------------------	--	--	--	--

INSTRUCTIONS TO CANDIDATES

- Write your name, centre number and candidate number in the boxes above. Please write clearly and in capital letters.
- Use black ink. HB pencil may be used for graphs and diagrams only.
- Answer **all** the questions.
- Read each question carefully. Make sure you know what you have to do before starting your answer.
- Your answers should be supported with appropriate working. Marks may be given for a correct method even if the answer is incorrect.
- Write your answer to each question in the space provided. Additional paper may be used if necessary but you must clearly show your candidate number, centre number and question number(s).
- Do **not** write in the bar codes.

INFORMATION FOR CANDIDATES

- The number of marks is given in brackets [] at the end of each question or part question.
- Your quality of written communication is assessed in questions marked with an asterisk (*).
- Use the π button on your calculator or take π to be 3.142 unless the question says otherwise.
- The total number of marks for this paper is **100**.
- This document consists of **24** pages. Any blank pages are indicated.

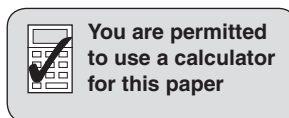

Formulae Sheet: Higher Tier

Area of trapezium = $\frac{1}{2}(a + b)h$

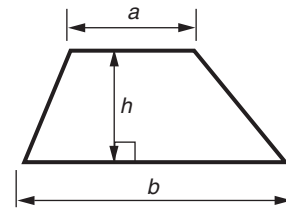

Volume of prism = (area of cross-section) \times length

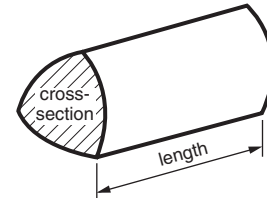

In any triangle ABC

Sine rule $\frac{a}{\sin A} = \frac{b}{\sin B} = \frac{c}{\sin C}$

Cosine rule $a^2 = b^2 + c^2 - 2bc \cos A$

Area of triangle = $\frac{1}{2}ab \sin C$

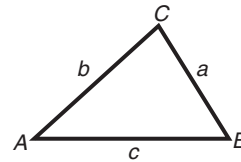

Volume of sphere = $\frac{4}{3}\pi r^3$

Surface area of sphere = $4\pi r^2$

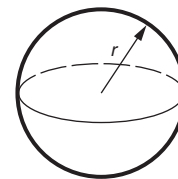

Volume of cone = $\frac{1}{3}\pi r^2 h$

Curved surface area of cone = $\pi r l$

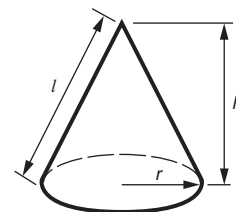

The Quadratic Equation

The solutions of $ax^2 + bx + c = 0$,
where $a \neq 0$, are given by

$$x = \frac{-b \pm \sqrt{b^2 - 4ac}}{2a}$$

PLEASE DO NOT WRITE ON THIS PAGE

Answer **all** the questions.

- 1 Terri travels to and from school by bus.
Here are the bus fares for different types of ticket.

Ticket type	Fare
1-way	£1.35
Return	£2.16
All week	£9.80

- (a) One week, Terri travels to school and back by bus on 5 days.

How much cheaper is it to buy an 'All week' ticket rather than '1-way' tickets?

(a) £ [1]

- (b) Express the ratio

cost of **two** '1-way' tickets : cost of **one** 'Return' ticket

in its simplest form.

(b) : [2]

2 (a) (i) Louise has these numbers of different types of teeth.

- 8 incisors
- 4 canine
- 8 premolars
- 12 molars

What fraction of Louise's teeth are molars?
Give your answer in its simplest form.

(a)(i) [2]

(ii) Finn has 27 teeth.
About 18% of his teeth have fillings.

How many of Finn's teeth have fillings?

(ii) [3]

(iii) Kirsten has 30 teeth.
 $\frac{2}{5}$ of her teeth have fillings.

How many of Kirsten's teeth have fillings?

(iii) [2]

(b) A dentist has this information about her patients.

Number of fillings	0	1 or 2	3 or 4	More than 4
Probability	0.25	0.17		0.4

(i) Complete the table.

[2]

(ii) One of the patients is chosen at random.

What is the probability that this person has 2 fillings or fewer?

(b)(ii) [2]

(iii) Two of the patients are chosen at random.

Calculate the probability that they both have more than 4 fillings.

(iii) [2]

(iv) The dentist has 1500 patients altogether.

How many of these patients have 1 or 2 fillings?

(iv) [2]

(c) Finn and Kirsten both visit the dentist.
 The probability that the dentist **does not** see any patient on time is 0.2.

(i) Complete the tree diagram.

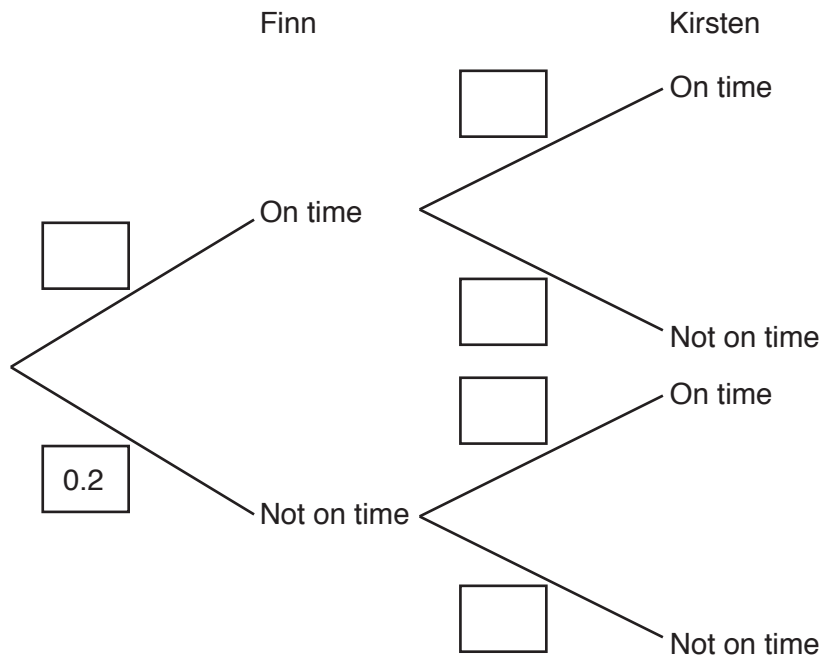

[2]

(ii) Calculate the probability that just one of Finn and Kirsten is not seen on time.

(c)(ii) [3]

- 3 A right-angled triangle is cut from a rectangular piece of paper.

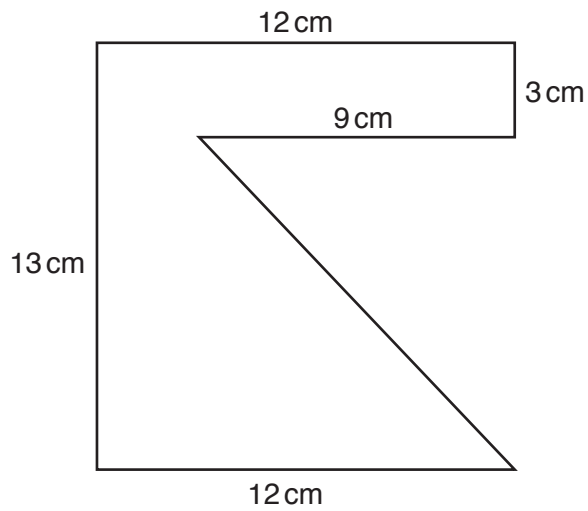

Not to scale

- (a) Calculate the area of the paper remaining.

(a) cm^2 [3]

- (b) Change your answer to part (a) into mm^2 .

(b) mm^2 [1]

4 (a) Simplify fully.

$$\frac{16y^4}{2y^2}$$

(a) [2]

(b) Multiply out the brackets.

$$4x^2(x - 6)$$

(b) [2]

(c) Multiply out the brackets and simplify fully.

$$3(x - 7) + 5(2x + 1)$$

(c) [3]

- 5 A four-sided spinner is numbered 1 to 4.
 The spinner is spun many times and, each time, the number it lands on is recorded.
 The table shows the results.

Number	1	2	3	4
Frequency	132	117	128	123

- (a) Explain why it is reasonable to use this information to work out an estimate of the probability of getting a 4 with this spinner.

.....
 [1]

- (b) Use the values in the table to work out an estimate of the probability of getting a 4 with this spinner.

(b) [2]

- (c) Is the spinner fair or biased?
 Explain clearly how you decide.

.....
 [2]

6* The case shown below is used to store a travel card.

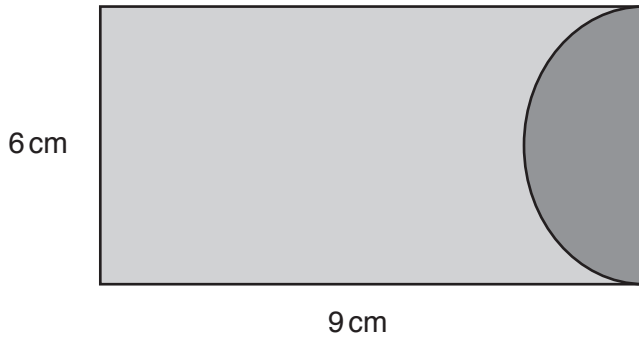

Not to scale

The case is two rectangles of leather joined together. One of the rectangles has a semicircle cut away.

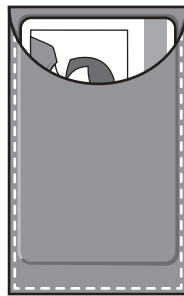

Work out the total area of leather in the case.

..... [6]

7 (a) Factorise fully.

$$4xy - 10xw$$

(a) [2]

(b) Solve.

$$x^2 = 49$$

(b) [2]

(c) Use the quadratic formula to solve this equation.

$$3x^2 - 2x - 7 = 0$$

Give your answers correct to 2 decimal places.

(c) [4]

8 Triangles ABC and PQR are mathematically similar.

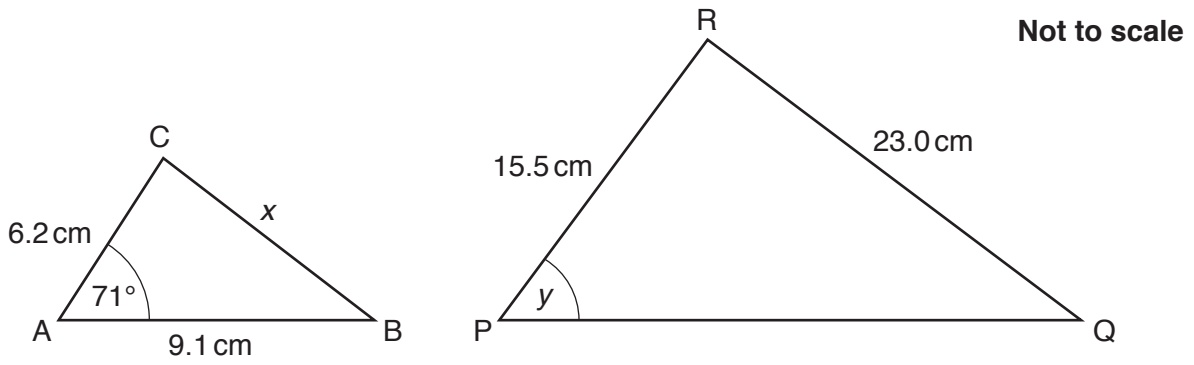

(a) Calculate length x .

(a) cm [3]

(b) What is the size of angle y ?

(b) ° [1]

(c) Show that the area of triangle ABC is 26.7 cm^2 , correct to 1 decimal place.

[2]

(d) Work out the area of triangle PQR.

(d) cm^2 [2]

9 (a) Complete the table for $y = x^2 + 3x - 2$.

x	-4	-3	-2	-1	0	1	2
y	2	-2					8

[2]

(b) On the grid, draw the graph of $y = x^2 + 3x - 2$ for $-4 \leq x \leq 2$.

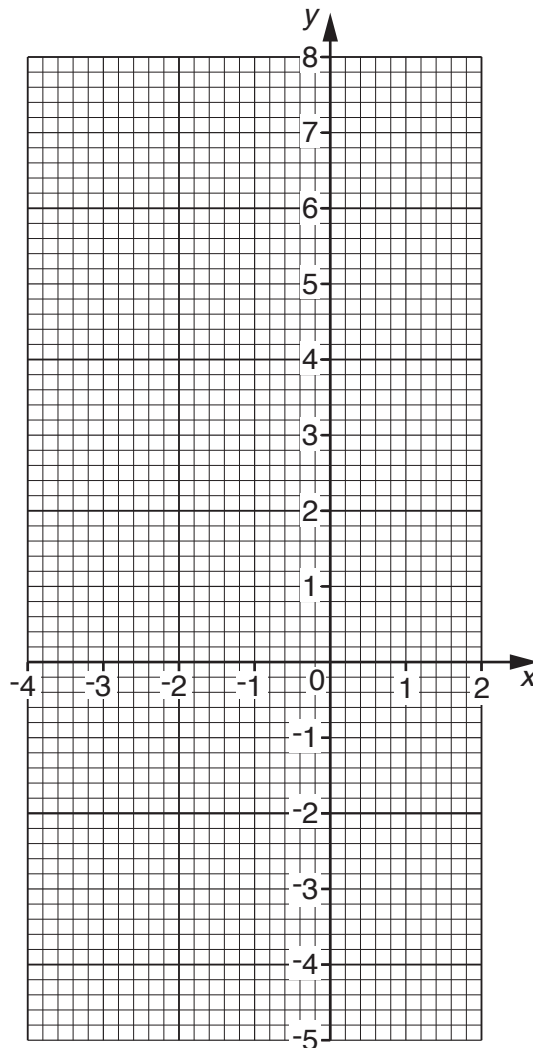

[2]

(c) Use your graph to solve the equation $x^2 + 3x - 2 = 0$.

(c) [2]

- 10 (a) Mehdi invests £4000 at a rate of 2% compound interest each year.
Calculate how much the investment is worth after 3 years.

(a) £ [3]

- (b) Alec earned £8164 in one year.
This was an increase of 4% on his earnings for the previous year.

Calculate Alec's earnings for the previous year.

(b) £ [3]

11 (a) Write these in order, smallest first.

7.1×10^5

7.01×10^{-5}

7.1×10^{-5}

7.01×10^{-6}

..... [3]
smallest

(b) The distance of the Sun from the Earth is 150 000 000 kilometres.
 The speed of light is 3.0×10^8 metres per second.

Calculate the time, in seconds, it takes for light to travel from the Sun to the Earth.

(b) seconds [3]

12 Here is a triangle.

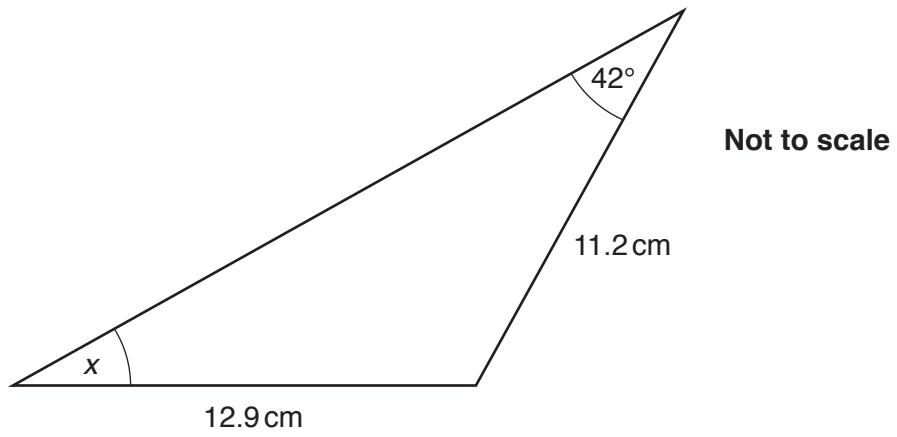

Work out the size of angle x .

.....° [3]

13 The tower of a castle is a cylinder topped with a cone.

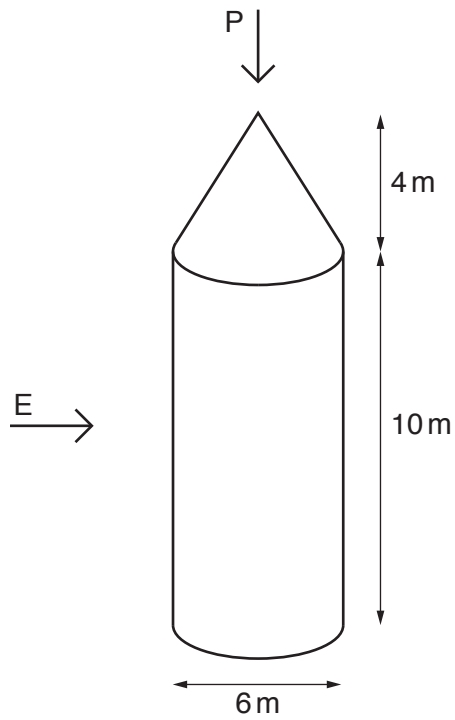

(a) Draw the side elevation (view from E) of the tower.
 Use a scale of 1 square to 2 m.

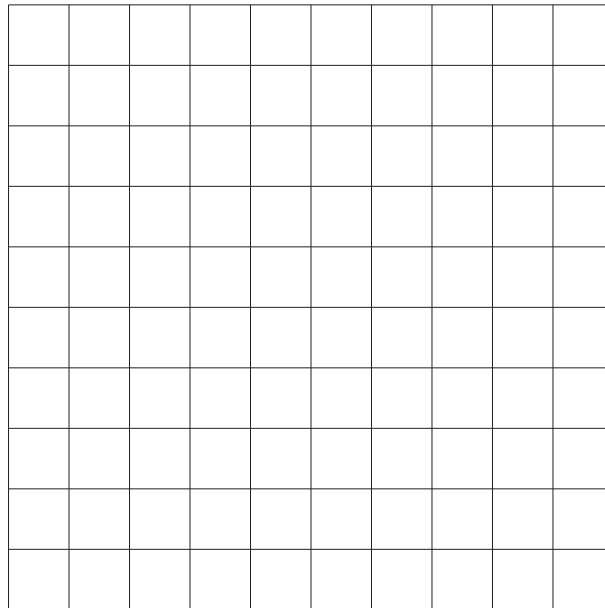

Side elevation

[2]

- (b) Draw the plan (view from P) of the tower.
Use a scale of 1 square to 1 m.

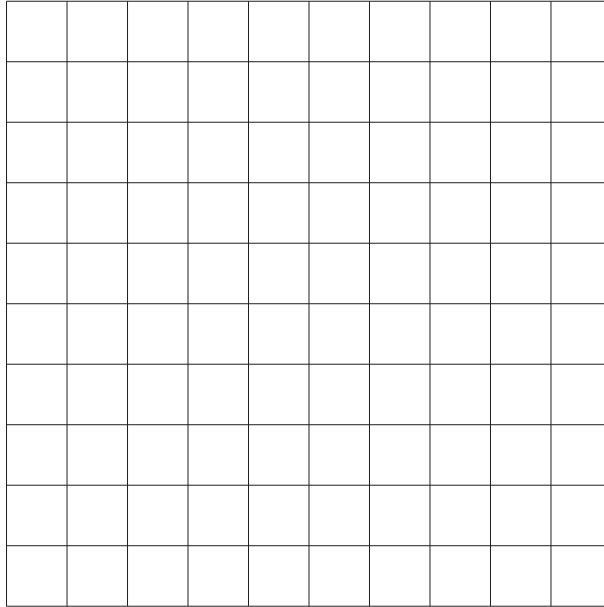

Plan

[2]

- (c) Work out the volume of the tower.
Give your answer in terms of π , in its simplest form.

(c) cm³ [4]

14 (a) Simplify fully.

$$\frac{x^2 - 5x + 4}{x^2 - 2x - 8}$$

(a) [4]

(b) Work out the value of a and the value of b in this identity.

$$x^2 - 8x + b \equiv (x + a)^2 + 2$$

(b) $a =$

$b =$ [3]

15 (a) Here is a sketch graph of $y = f(x)$.

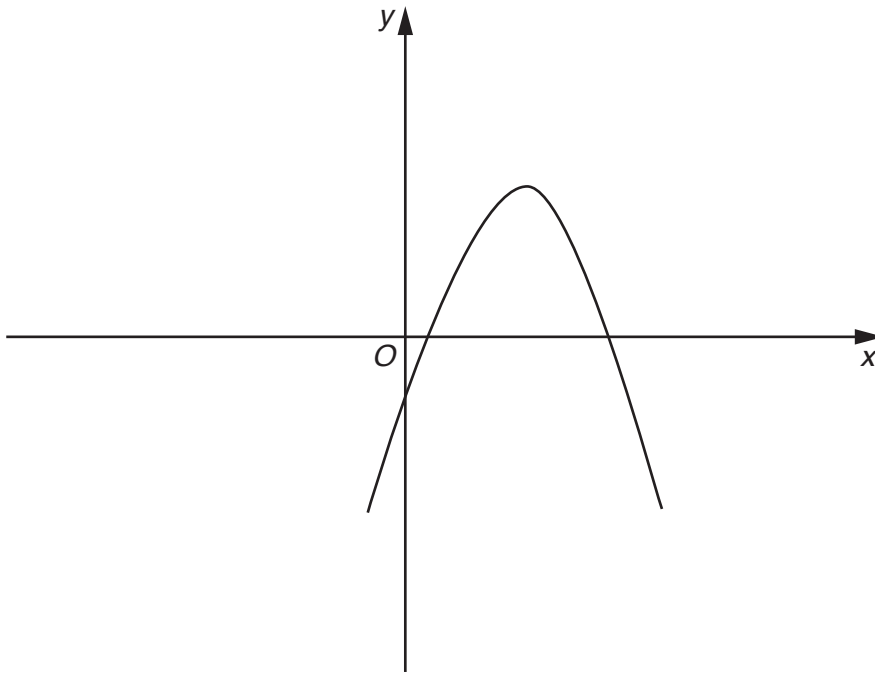

On the same diagram, sketch the graph of $y = f(x - 2)$.

[1]

(b) In each part, write down the equation of the transformed graph.

(i)

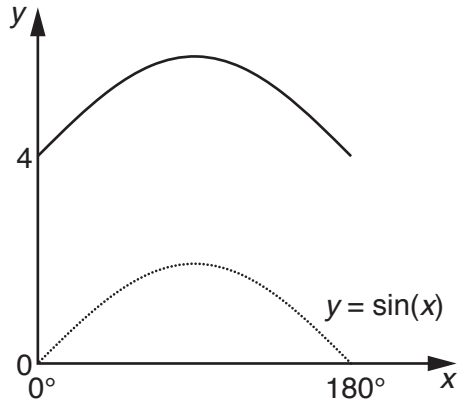

(b)(i) [1]

(ii)

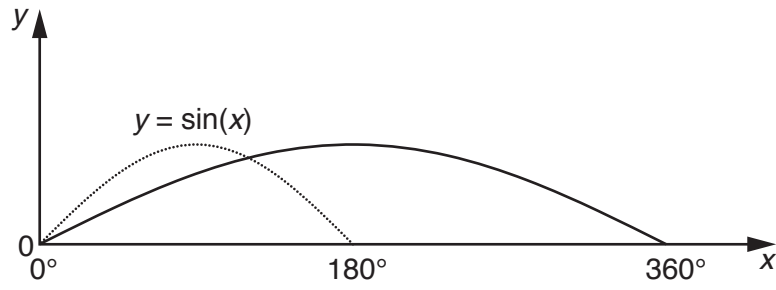

(ii) [1]

END OF QUESTION PAPER

PLEASE DO NOT WRITE ON THIS PAGE

PLEASE DO NOT WRITE ON THIS PAGE

OCR
Oxford Cambridge and RSA

Copyright Information

OCR is committed to seeking permission to reproduce all third-party content that it uses in its assessment materials. OCR has attempted to identify and contact all copyright holders whose work is used in this paper. To avoid the issue of disclosure of answer-related information to candidates, all copyright acknowledgements are reproduced in the OCR Copyright Acknowledgements Booklet. This is produced for each series of examinations and is freely available to download from our public website (www.ocr.org.uk) after the live examination series.

If OCR has unwittingly failed to correctly acknowledge or clear any third-party content in this assessment material, OCR will be happy to correct its mistake at the earliest possible opportunity.

For queries or further information please contact the Copyright Team, First Floor, 9 Hills Road, Cambridge CB2 1GE.

OCR is part of the Cambridge Assessment Group; Cambridge Assessment is the brand name of University of Cambridge Local Examinations Syndicate (UCLES), which is itself a department of the University of Cambridge.