

Thursday 8 June 2017 – Afternoon

AS GCE PHYSICS A

G482/01 Electrons, Waves and Photons

Candidates answer on the Question Paper.

OCR supplied materials:

- Data, Formulae and Relationships Booklet (sent with general stationery)

Other materials required:

- Electronic calculator

Duration: 1 hour 45 minutes

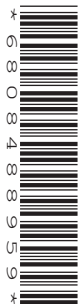

Candidate forename		Candidate surname	
--------------------	--	-------------------	--

Centre number						Candidate number				
---------------	--	--	--	--	--	------------------	--	--	--	--

INSTRUCTIONS TO CANDIDATES

- Write your name, centre number and candidate number in the boxes above. Please write clearly and in capital letters.
- Use black ink. HB pencil may be used for graphs and diagrams only.
- Answer **all** the questions.
- Read each question carefully. Make sure you know what you have to do before starting your answer.
- Write your answer to each question in the space provided. If additional space is required, you should use the lined page at the end of this booklet. The question number(s) must be clearly shown.
- Do **not** write in the barcodes.

INFORMATION FOR CANDIDATES

- The number of marks is given in brackets [] at the end of each question or part question.
- The total number of marks for this paper is **100**.
- You may use an electronic calculator.
- You are advised to show all the steps in any calculations.
-  Where you see this icon you will be awarded marks for the quality of written communication in your answer.
This means for example you should:
 - ensure that text is legible and that spelling, punctuation and grammar are accurate so that meaning is clear;
 - organise information clearly and coherently, using specialist vocabulary when appropriate.
- This document consists of **20** pages. Any blank pages are indicated.

Answer **all** the questions.

- 1** Many filament lamps are now obsolete. They have been replaced by light-emitting diode (LED) technology. For example, an 8.7 W LED lamp has replaced the 60 W mains filament lamp.

- (a)** A 60 W filament lamp is connected to the 230 V supply.
Calculate

- (i)** the current I drawn from the supply

$$I = \dots\dots\dots \text{ A [2]}$$

- (ii)** the resistance R of the filament.

$$R = \dots\dots\dots \Omega \text{ [1]}$$

- (b)** The filament temperature is 2800 K when the lamp is lit. At this temperature, the cross-sectional area of the filament wire is $4.8 \times 10^{-8} \text{ m}^2$. The material of the filament has resistivity $7.0 \times 10^{-5} \Omega \text{ m}$.

- (i)** Calculate the length of the filament wire using your value for R from **(a)(ii)**.

$$\text{length} = \dots\dots\dots \text{ m [3]}$$

- (ii) At the end of its lifetime, the filament of the lamp usually breaks immediately after the lamp is switched on, rather than after glowing for some time. Suggest a reason for this behaviour.

.....
.....
.....
.....
.....
..... [3]

- (c) An 8.7W LED lamp is left on for 3.0 hours.
Calculate the charge passing through the lamp in this time.

charge = unit [3]

- (d) The lifetime of the 60W filament lamp is advertised to be 1500 hours, whilst for the 8.7W LED lamp the figure is 15000 hours. Each lamp costs £1.00.
The cost of 1 kWh is 12p.
Calculate the saving made by changing from a filament lamp to an LED lamp over the lifetime of the LED lamp.

saving = £ [3]

- 2 A 120 V power supply with negligible internal resistance is connected to four resistors, as shown in Fig. 2.1.

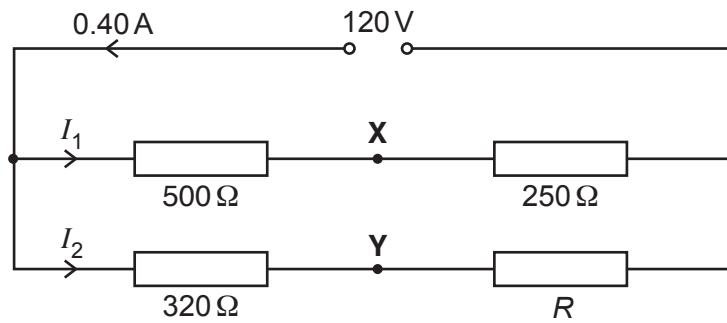

Fig. 2.1

The resistance values of the four resistors are $500\ \Omega$, $250\ \Omega$, $320\ \Omega$ and R . The current from the supply is 0.40 A . The currents in the two branches are I_1 and I_2 as shown.

(a) Calculate

(i) current I_1

$$I_1 = \dots\dots\dots \text{ A [2]}$$

(ii) resistance R .

$$R = \dots\dots\dots \ \Omega \text{ [2]}$$

(b) Two points in Fig. 2.1 are labelled **X** and **Y**.

(i) Calculate the potential difference V_{XY} between **X** and **Y**.

$$V_{XY} = \dots\dots\dots \text{ V [2]}$$

(ii) The resistor of resistance R in Fig. 2.1 is changed to one with a lower resistance. The rest of the circuit remains unchanged. State and explain the effect on

current I_1

.....
 [1]

current I_2

.....
 [1]

potential difference V_{XY}

.....

 [1]

Question 2 is continued on page 6

- (c) The resistor of resistance R is now replaced by a thermistor. The variation of resistance with temperature for the thermistor is shown in Fig. 2.2.

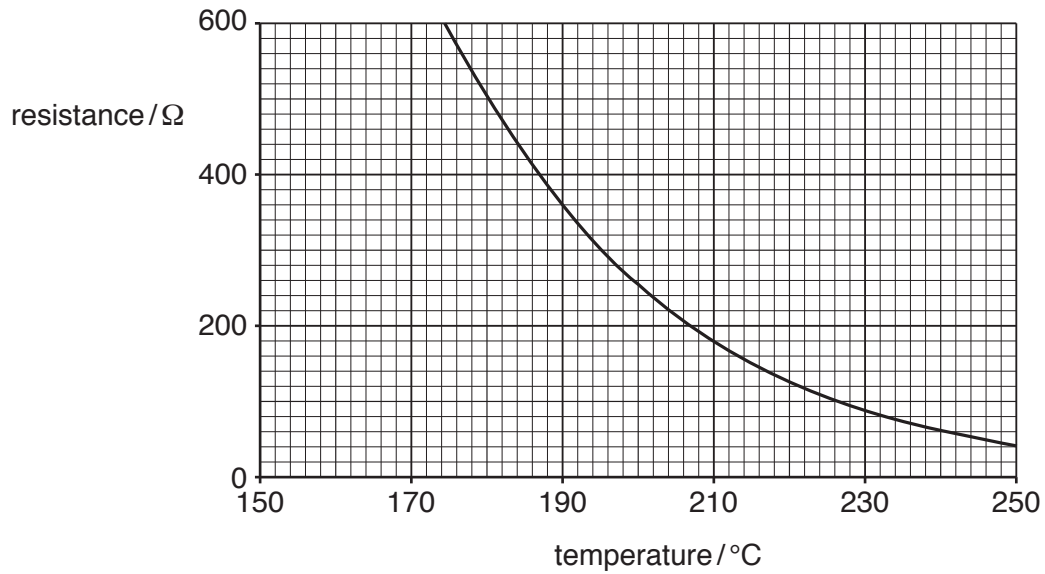

Fig. 2.2

- (i) Complete the circuit symbol for a thermistor on the symbol labelled R in Fig. 2.1. [1]
- (ii) In an experiment the thermistor is mounted (on long conducting leads) in an oven. The temperature of the oven must be kept between 200 $^{\circ}\text{C}$ and 220 $^{\circ}\text{C}$. The temperature can be monitored by an ammeter placed at **Y** or by a voltmeter placed between **X** and **Y**.
- 1 Show that the ratio $\frac{\text{change in current}}{\text{change in temperature}}$ is 3 mA K^{-1} between 200 $^{\circ}\text{C}$ and 220 $^{\circ}\text{C}$.

[3]

- 2 Hence show that the ratio $\frac{\text{change in voltage}}{\text{change in temperature}}$ is 1 V K^{-1} between 200 $^{\circ}\text{C}$ and 220 $^{\circ}\text{C}$.

[2]

3 Explain why it is better to measure the voltage across **XY** than the current at **Y**.

.....

.....

.....

..... [2]

3 (a) (i) Define the term *electromotive force*.

.....
.....
..... [2]

(ii) Explain, in the context of energy transfer, the meaning of the term *internal resistance*.

.....
.....
..... [1]

(b) You are asked to plan an experiment to determine the e.m.f. E and internal resistance r of a cell. The plan is to include a circuit diagram with two meters and a variable resistor. The data collected is to be plotted on a graph from which E and r can be determined.

The e.m.f. of the cell is about 6 V and r is about $2\ \Omega$. The maximum resistance of the variable resistor is $18\ \Omega$. Suggest a maximum scale reading for each of the meters to be used in the experiment.



In your answer you should state how the graph is used to determine the values of E and r .

.....
.....
.....
.....
.....
.....
.....
.....
.....
..... [5]

(c) Fig. 3.1 shows the I - V characteristic of a 6.0V 1.5W filament lamp.

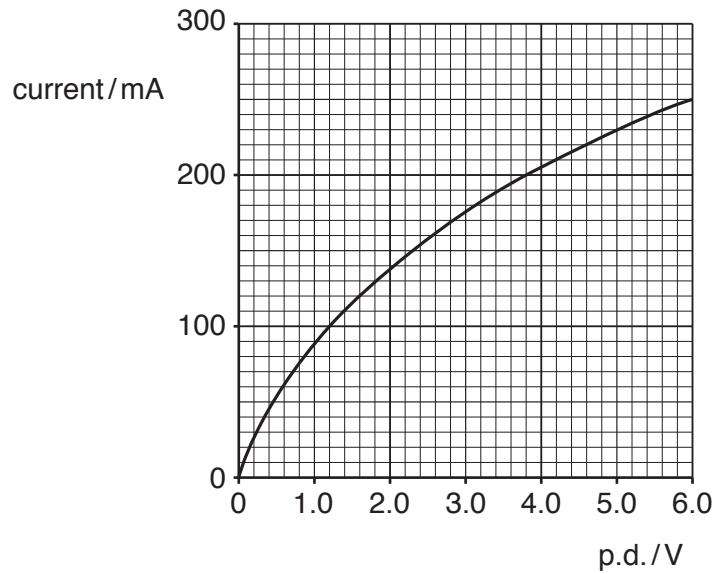

Fig. 3.1

(i) The student is asked to verify that these data are correct using a lamp with the equipment that has just been used for (b) above. On Fig. 3.2(a) complete the circuit required to perform this task.

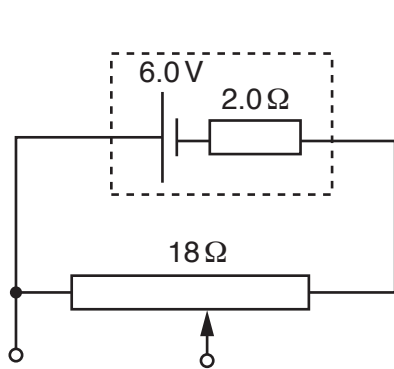

Fig. 3.2(a)

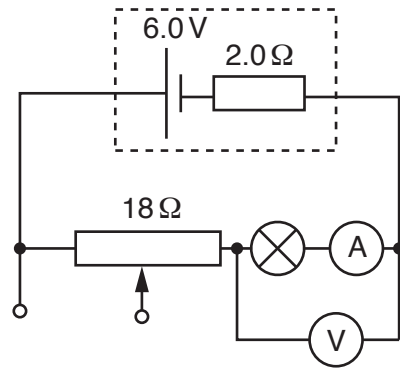

Fig. 3.2(b)

[2]

(ii) The student mistakenly connects the circuit shown in Fig. 3.2(b). By drawing a I - V characteristic for the resistors of total resistance 20Ω on Fig. 3.1, or otherwise, determine the reading on each meter. Make your reasoning clear.

ammeter reading = A

voltmeter reading = V

[5]

4 Fig. 4.1 shows a loudspeaker mounted on a bench and connected to a signal generator.

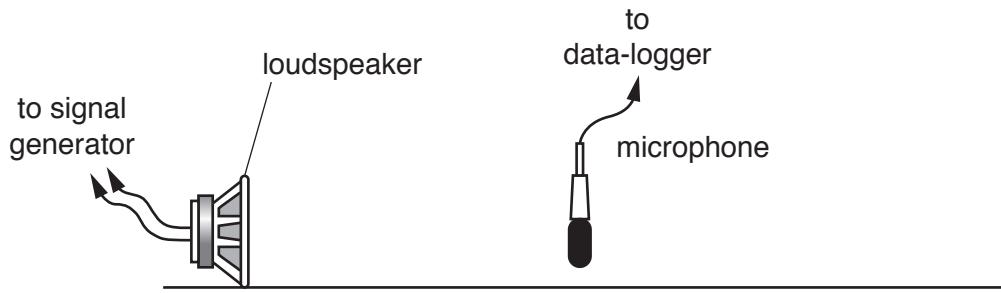

Fig. 4.1

The voltage output from a microphone placed as shown is processed through a data-logger to produce the displacement y of the air against time t graph shown in Fig. 4.2.

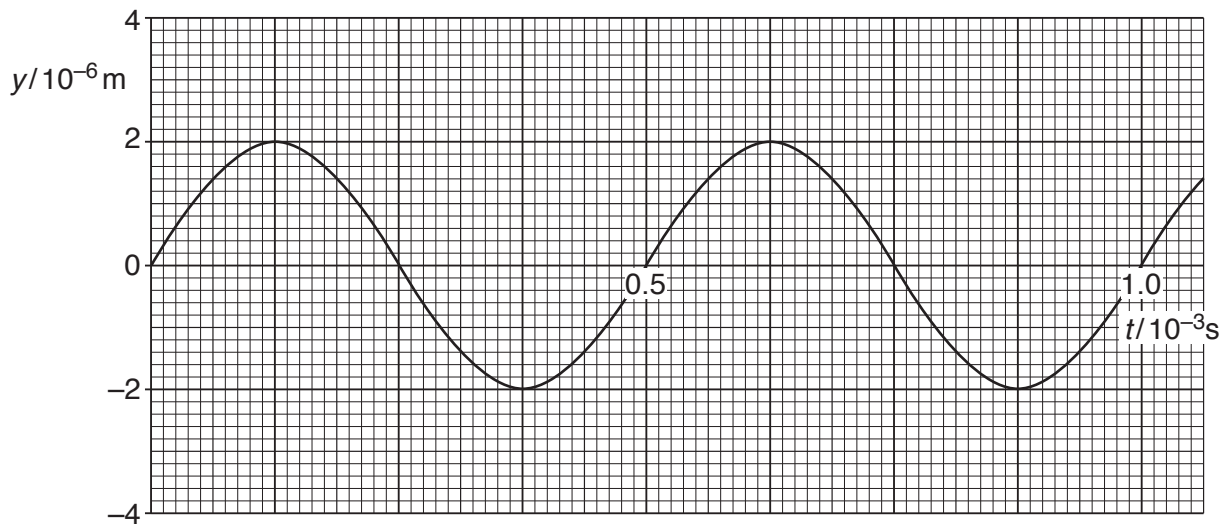

Fig. 4.2

(a) The speed of sound in air is 340 ms^{-1} .
Calculate

(i) the frequency f of oscillation of the air

$f = \dots\dots\dots \text{ Hz [2]}$

(ii) the wavelength λ of the sound.

$\lambda = \dots\dots\dots \text{ m [2]}$

(b) The microphone detects the presence of a longitudinal rather than a transverse wave. Explain the difference between the two types of wave motion.

.....
.....
.....
.....
.....
..... [2]

(c) (i) Explain the meaning of the term *phase difference*.

.....
.....
..... [2]

(ii) A second microphone is connected to the data-logger and placed 0.043 m to the right of the one shown in Fig. 4.1. Draw on Fig. 4.2 the variation of the displacement of the air with time at the position of the second microphone. Assume that the data-logger can record both sets of data on the same time scale to produce a graph displaying both curves. [2]

(iii) State the phase difference between the two oscillations in degrees or radians.

phase difference unit [1]

Question 4 is continued on page 12

- (d) A second loudspeaker is connected to the **same** signal generator and mounted on the bench facing the first as shown in Fig. 4.3. The microphone is at the midpoint along the line joining the two loudspeakers.

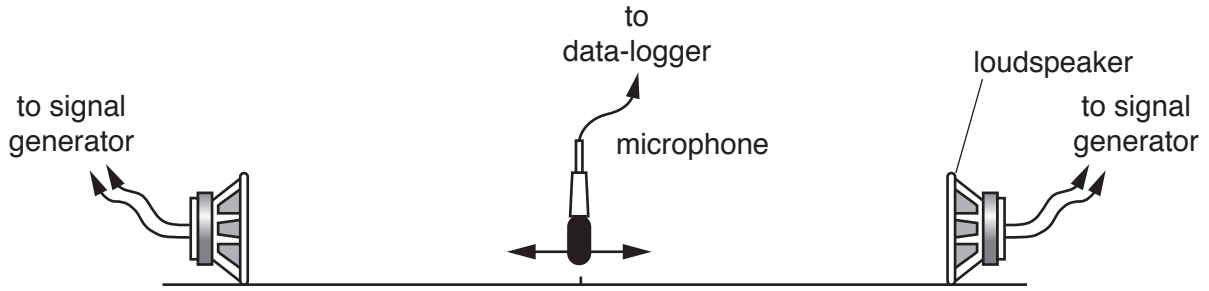

Fig. 4.3

When the microphone is moved to the left, or to the right, the amplitude of the detected signal changes.

- (i) Explain why the amplitude varies between maximum and minimum values.

.....

 [2]

- (ii) State, with a reason, the distance between adjacent minima.

.....

 distance: m [2]

- (iii) When the microphone is at the mid-point between the two loudspeakers explain why the amplitude of the detected signal is either a maximum or a minimum.

.....

 [3]

Question 5 begins on page 14

13
BLANK PAGE

PLEASE DO NOT WRITE ON THIS PAGE

(ii) Suggest how the observations from this experiment help to decide the orientation of the transmission axis in the lenses of Polaroid sunglasses.

.....
.....
.....
..... [2]

(d) Ultraviolet radiation from the Sun is divided into three regions UV-A, UV-B and UV-C.

(i) Explain why UV-B is more dangerous to sunbathers than the other two.

.....
.....
.....
..... [2]

(ii) Explain how sunscreen protects the human skin.

.....
..... [1]

(e) When an electron is accelerated from rest through a potential difference of 500 V it has a de Broglie wavelength equal to that of a gamma ray photon.

Calculate this wavelength in picometres (pm).

wavelength = pm [5]

6 The spectrum of light from a sodium vapour lamp consists of a line spectrum. The wavelengths of three spectral lines are shown in the table below.

spectral line	wavelength / nm
R	615
Y	589
G	570

(a) Explain what is meant by a *line* spectrum.

.....
 [1]

(b) The **Y** spectral line has about double the intensity of the other two which are approximately equal. On Fig. 6.1, sketch a graph to represent the relative intensity-wavelength relation for these three lines. Label them **R**, **Y** and **G**.

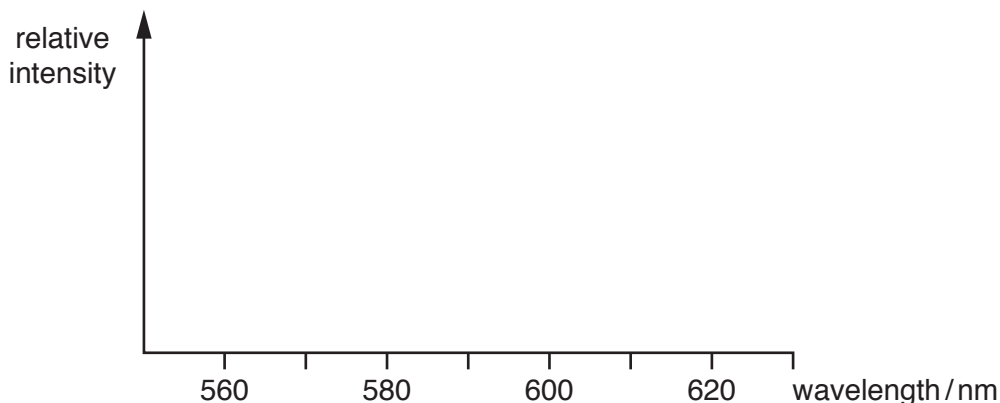

Fig. 6.1

[2]

(c) Calculate, clearly showing your working, the ratio

$$\frac{\text{energy of a photon producing G}}{\text{energy of a photon producing Y}}$$

ratio = [2]

- (d) The energy level diagram shown in Fig. 6.2 is for the atoms in the lamp emitting light at the three spectral lines **R**, **Y** and **G**. The three electron transitions shown between the four levels **A**, **B**, **C** and **D** produce the three different photons. The energy E of an electron bound to an atom is negative.

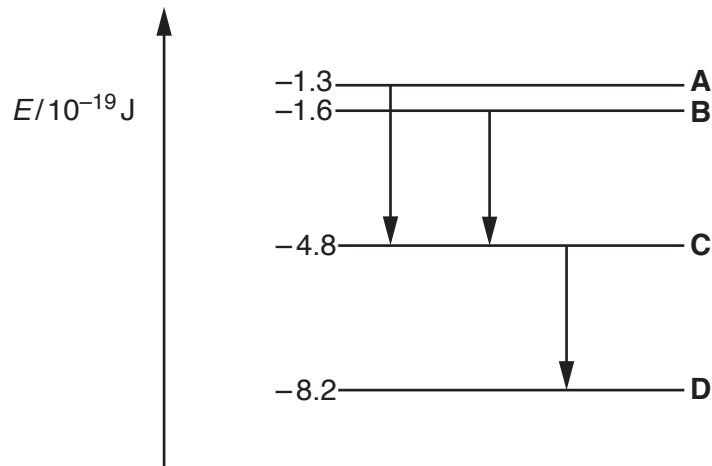

Fig. 6.2 (not to scale)

Label the arrows on Fig. 6.2 **R**, **Y** and **G** to indicate which transition results in which photon. [2]

- (e) Light from the sodium lamp is analysed by passing it through a diffraction grating.

The line separation d of the grating is $1.67 \times 10^{-6} \text{ m}$.

- (i) Calculate the angular spread of the first order spectrum, that is, the angle between the outer lines in Fig. 6.1.

angle = ° [4]

Question 6 is continued on page 18

- (ii) Calculate how many **R** lines appear over the 180° in front of the grating. Ignore the zeroth order spectral line.

number of **R** lines = [2]

- (f) Fig. 6.3 shows a circuit containing a photoelectric cell. Light from the sodium lamp falls on its cathode and photoelectrons are emitted from the cathode.

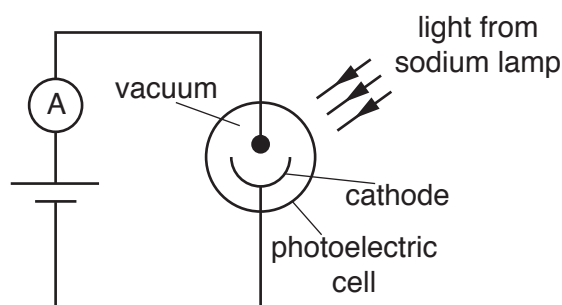

Fig. 6.3

- (i) Explain, in terms of the photoelectric effect, why there is a current in this circuit.

.....

 [3]

- (ii) Each of the component wavelengths, **R**, **Y** and **G**, is shone in turn on the cathode of the photocell. Predict which wavelength is least likely to produce electron emission. Give a reason for your answer.

.....

 [2]

ADDITIONAL ANSWER SPACE

If additional space is required, you should use the following lined page(s). The question number(s) must be clearly shown in the margin(s).

A large area of lined paper for writing, consisting of 25 horizontal dotted lines. A solid vertical line runs down the left side of the page, creating a margin. The rest of the page is open for writing.

A large area of the page is reserved for writing, featuring a vertical solid line on the left side and horizontal dotted lines extending across the page.



Copyright Information

OCR is committed to seeking permission to reproduce all third-party content that it uses in its assessment materials. OCR has attempted to identify and contact all copyright holders whose work is used in this paper. To avoid the issue of disclosure of answer-related information to candidates, all copyright acknowledgements are reproduced in the OCR Copyright Acknowledgements Booklet. This is produced for each series of examinations and is freely available to download from our public website (www.ocr.org.uk) after the live examination series.

If OCR has unwittingly failed to correctly acknowledge or clear any third-party content in this assessment material, OCR will be happy to correct its mistake at the earliest possible opportunity.

For queries or further information please contact the Copyright Team, First Floor, 9 Hills Road, Cambridge CB2 1GE.

OCR is part of the Cambridge Assessment Group; Cambridge Assessment is the brand name of University of Cambridge Local Examinations Syndicate (UCLES), which is itself a department of the University of Cambridge.