

Please check the examination details below before entering your candidate information

Candidate surname

Other names

**Pearson Edexcel  
Level 3 GCE**

Centre Number

--	--	--	--	--

Candidate Number

--	--	--	--	--

**Time** 1 hour 45 minutes

**Paper  
reference**

**9PH0/01**

**Physics**

**Advanced**

**PAPER 1: Advanced Physics I**

**You must have:**

Scientific calculator, ruler

Total Marks

## Instructions

- Use **black** ink or ball-point pen.
- **Fill in the boxes** at the top of this page with your name, centre number and candidate number.
- Answer **all** questions.
- Answer the questions in the spaces provided  
– *there may be more space than you need.*

## Information

- The total mark for this paper is 90.
- The marks for **each** question are shown in brackets  
– *use this as a guide as to how much time to spend on each question.*
- In questions marked with an **asterisk** (\*), marks will be awarded for your ability to structure your answer logically, showing how the points that you make are related or follow on from each other where appropriate.
- The list of data, formulae and relationships is printed at the end of this booklet.

## Advice

- Read each question carefully before you start to answer it.
- Try to answer every question.
- Check your answers if you have time at the end.
- You are advised to show your working in calculations including units where appropriate.
- Good luck with your examination.

Turn over ►

P67096A

©2021 Pearson Education Ltd.

1/1/1/



Pearson

Answer ALL questions.

All multiple choice questions must be answered with a cross  in the box for the correct answer from A to D. If you change your mind about an answer, put a line through the box  and then mark your new answer with a cross .

- 1 The graph shows how a potential difference (p.d.) varies with time.

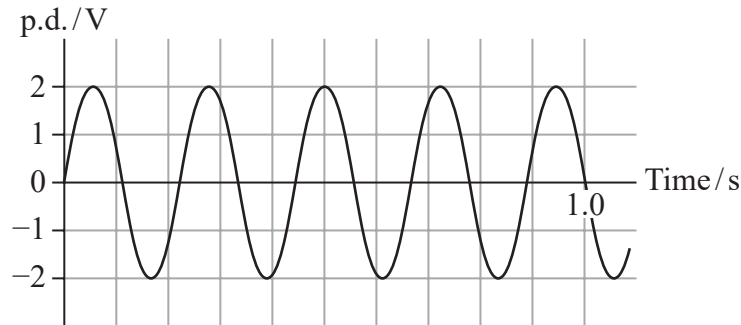

Which of the following is correct?

- A The frequency is 4.5 Hz.  
 B The peak value is 4.0 V.  
 C The period is 0.20 s.  
 D The root mean square value of p.d. is 1.0 V.

(Total for Question 1 = 1 mark)

- 2 The  $\pi^-$  particle has a mass of  $140 \text{ MeV}/c^2$ .

Which row of the table is correct for the antiparticle of a  $\pi^-$ ?

	Particle classification	Mass/ $\text{MeV}/c^2$
<input type="checkbox"/> A	Baryon	+140
<input type="checkbox"/> B	Baryon	-140
<input type="checkbox"/> C	Meson	+140
<input type="checkbox"/> D	Meson	-140

(Total for Question 2 = 1 mark)



- 3 A ball was dropped from rest, from a height above the ground. The ball bounced back up to about half its initial height.

Which graph shows how the velocity  $v$  of the ball varied with time  $t$ ?

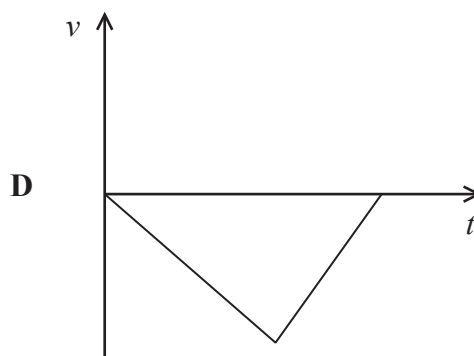
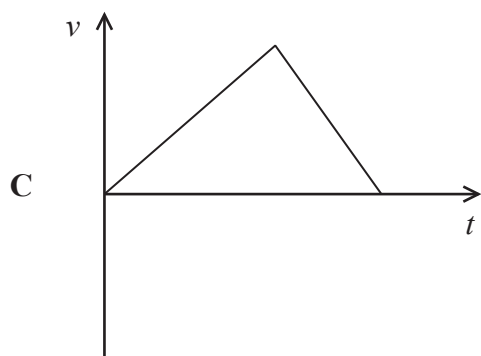
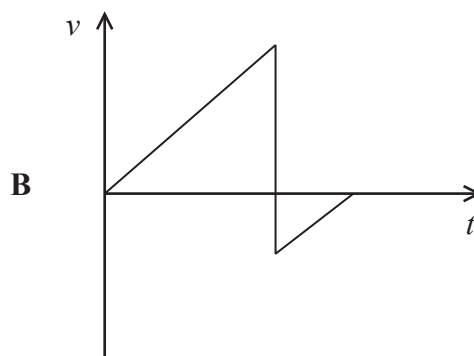
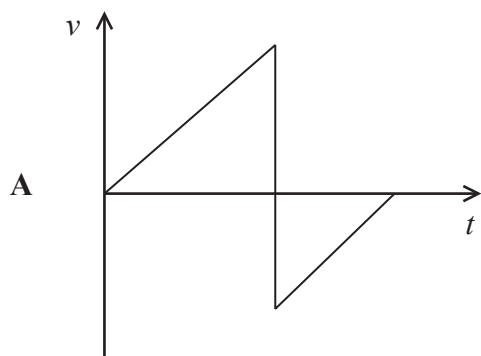

- A
- B
- C
- D

(Total for Question 3 = 1 mark)



Questions 4 and 5 refer to the information below.

Two resistors are connected in parallel and the current in one of them is 2.0 A, as shown.

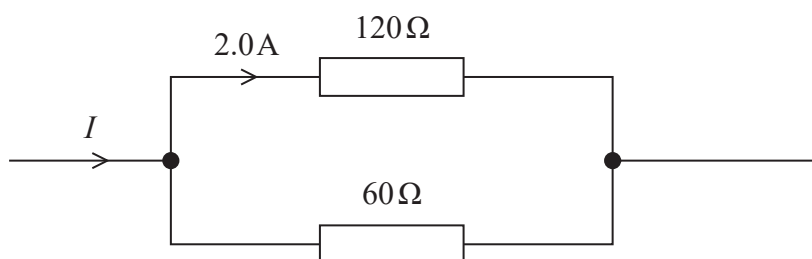

4 Which of the following is the current  $I$  in ampere?

- A 3.0
- B 4.0
- C 5.0
- D 6.0

(Total for Question 4 = 1 mark)

5 Which of the following is the total resistance of the resistors in parallel?

- A  $20\ \Omega$
- B  $40\ \Omega$
- C  $90\ \Omega$
- D  $180\ \Omega$

(Total for Question 5 = 1 mark)

DO NOT WRITE IN THIS AREA

DO NOT WRITE IN THIS AREA

DO NOT WRITE IN THIS AREA



- 6 A trapdoor is fixed to a vertical wall with a hinge. A wire is attached to the other end of the trapdoor and inclined at an angle of  $60^\circ$ , as shown. The wire holds the trapdoor horizontal.

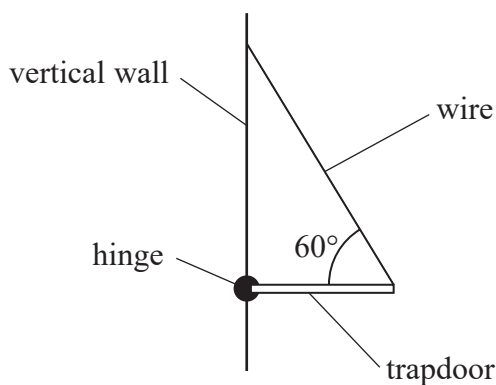

Which of the following shows the free-body force diagram for the trapdoor?

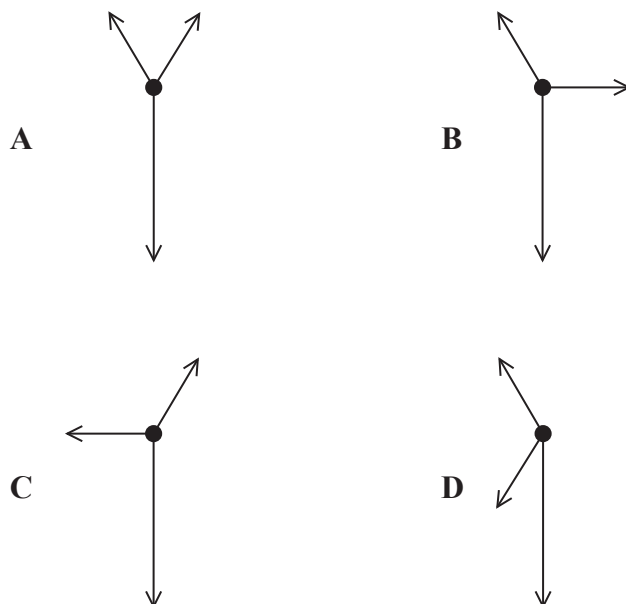

- A
- B
- C
- D

(Total for Question 6 = 1 mark)



- 7 A light dependent resistor (LDR) and a resistor are connected to a battery, as shown.

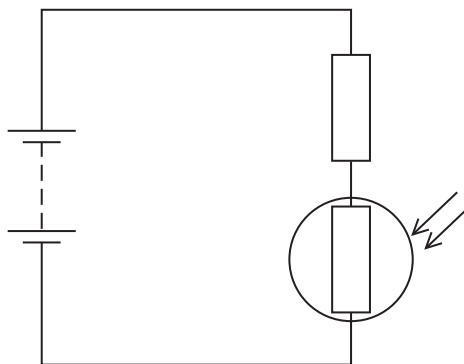

The intensity of light incident on the LDR increases.

Which row of the table describes the change in the resistance of the LDR and the change in the potential difference across the resistor?

	Resistance of LDR	Potential difference across the resistor
<input type="checkbox"/> A	decreases	decreases
<input type="checkbox"/> B	decreases	increases
<input type="checkbox"/> C	increases	decreases
<input type="checkbox"/> D	increases	increases

(Total for Question 7 = 1 mark)

- 8 A potential difference is applied across two parallel plates. A particle carrying a charge of  $+0.1\text{ C}$  is placed between the plates and experiences a force  $F$ .

The distance between the plates is halved. The potential difference remains constant.

Which of the following is now equal to the electric field strength between the plates?

- A  $5F$
- B  $10F$
- C  $20F$
- D  $40F$

(Total for Question 8 = 1 mark)



9 A capacitor is connected to a power supply and charged to a potential difference  $V_0$ .

The graph shows how the potential difference  $V$  across the capacitor varies with the charge  $Q$  on the capacitor.

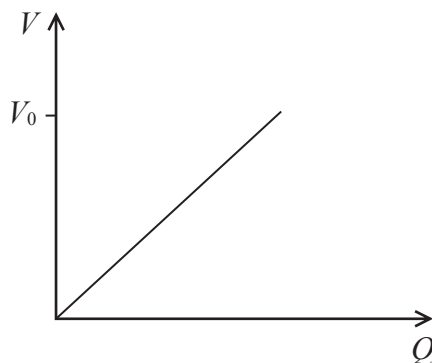

At a potential difference  $V_0$  a small charge  $\Delta Q$  is added to the capacitor. This results in a small increase in potential difference  $\Delta V$  across the capacitor.

Which of the following gives the approximate increase in energy stored on the capacitor due to this extra charge?

- A  $\Delta V \times \Delta Q$
- B  $\frac{\Delta V \Delta Q}{2}$
- C  $V_0 \times \Delta Q$
- D  $\frac{V_0 \Delta Q}{2}$

(Total for Question 9 = 1 mark)

10 Which of the following is a unit of magnetic flux?

- A  $\text{NC}^{-1}$
- B  $\text{Tm}^{-2}$
- C  $\text{Vs}$
- D  $\text{Wbm}^2$

(Total for Question 10 = 1 mark)



11 The International Space Station (ISS) orbits the Earth with a constant speed  $v$ . The orbit is circular and of radius  $r$ .

(a) The diagram represents two positions, A and B, of ISS during its orbit.

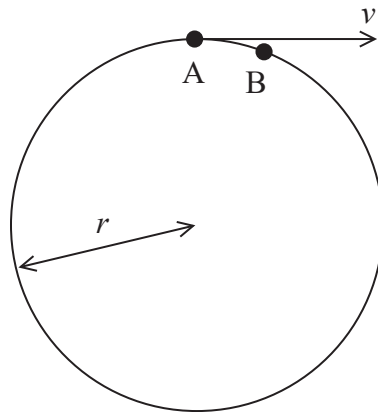

Draw a labelled vector diagram, in the space below, of the velocities at the two positions that shows the acceleration is directed towards the centre of the orbit.

(2)

DO NOT WRITE IN THIS AREA

DO NOT WRITE IN THIS AREA

DO NOT WRITE IN THIS AREA





DO NOT WRITE IN THIS AREA

DO NOT WRITE IN THIS AREA

DO NOT WRITE IN THIS AREA

(b) (i) The ISS completes one orbit in 92 minutes.

Calculate the centripetal acceleration of the ISS.

$$r = 6800 \text{ km}$$

(3)

.....

.....

.....

.....

.....

Centripetal acceleration = .....

(ii) Astronauts in the ISS are often described as being “weightless”.

Discuss whether the astronauts are “weightless” when they are orbiting the Earth in the ISS.

(4)

.....

.....

.....

.....

.....

.....

.....

.....

.....

.....

.....

**(Total for Question 11 = 9 marks)**



- 12 In the game of golf a stationary ball is hit by a club. One of the aims of the game is to land the ball on a patch of ground called the green.

The graph shows how the force  $F$  exerted by the club on the ball varies with time  $t$  as the ball is hit.

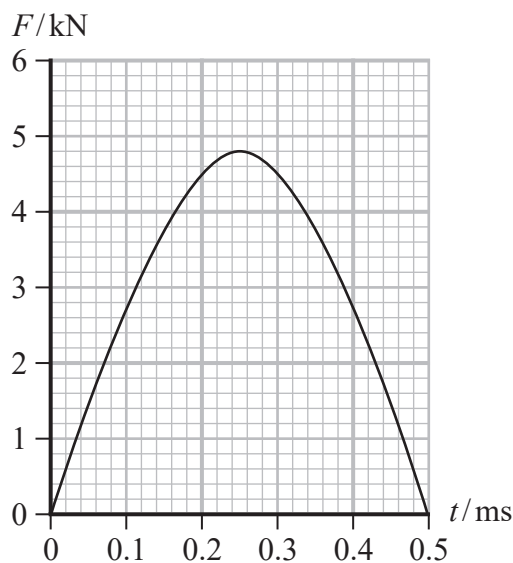

- (a) State why the area under the graph represents impulse.

(1)

- (b) (i) Show that the velocity of the ball is about  $30 \text{ ms}^{-1}$  immediately after it is hit by the club.

mass of ball =  $0.046 \text{ kg}$

(3)



- (ii) The ball has a time of flight of 3.5 s before landing. The green is a vertical distance of 7.5 m above the point at which the ball was hit, as shown. The green is about seventy metres away from where the ball is hit.

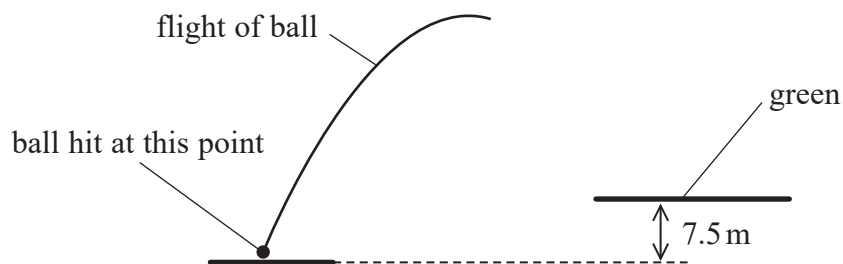

Deduce whether, if air resistance is ignored, the ball could land on the green after a flight time of 3.5 s.

(5)

(Total for Question 12 = 9 marks)



DO NOT WRITE IN THIS AREA

DO NOT WRITE IN THIS AREA

DO NOT WRITE IN THIS AREA

**BLANK PAGE**



DO NOT WRITE IN THIS AREA

DO NOT WRITE IN THIS AREA

DO NOT WRITE IN THIS AREA

13 The diagram shows two parallel metal plates with a potential difference (p.d.) of 100 V across them. Three equipotential lines are shown.

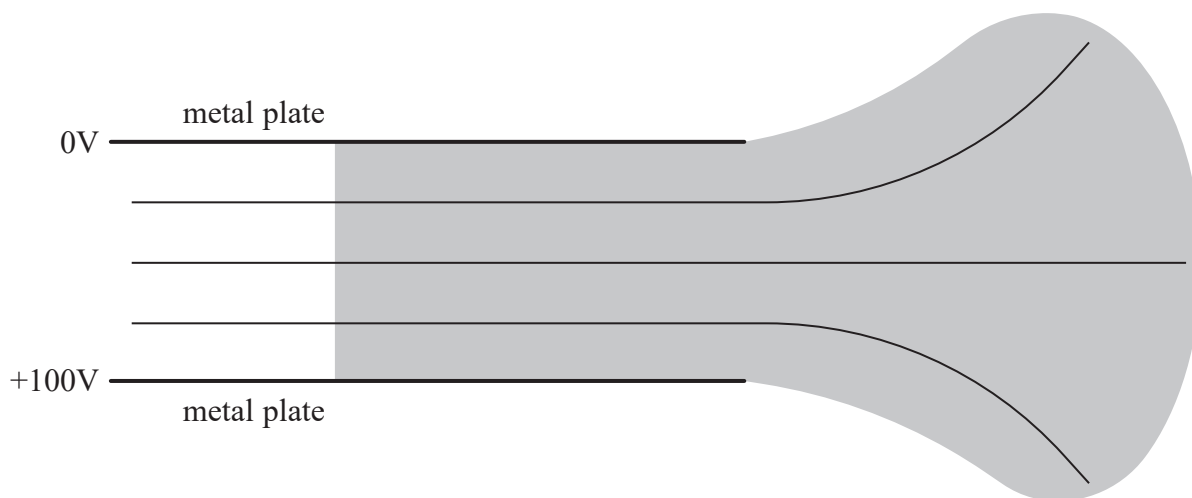

(a) Draw lines to represent the electric field in the shaded area.

(4)



- (b) A parallel plate capacitor consists of a thin layer of insulator of thickness  $d$  between two plates of conducting material of area  $A$ .

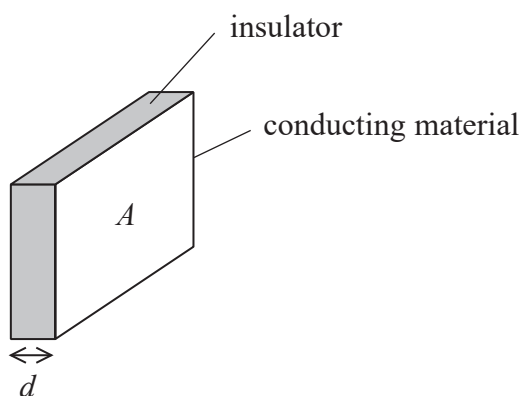

The capacitor has a capacitance  $0.1 \mu\text{F}$  and is charged to a p.d. of  $100 \text{ V}$  by connecting it to an electrical supply.

The capacitor is then disconnected from the supply and the p.d. between the two plates slowly decreases. This is because the insulator is not perfect and a small charge can flow through it.

The graph shows how the p.d. varies with time.

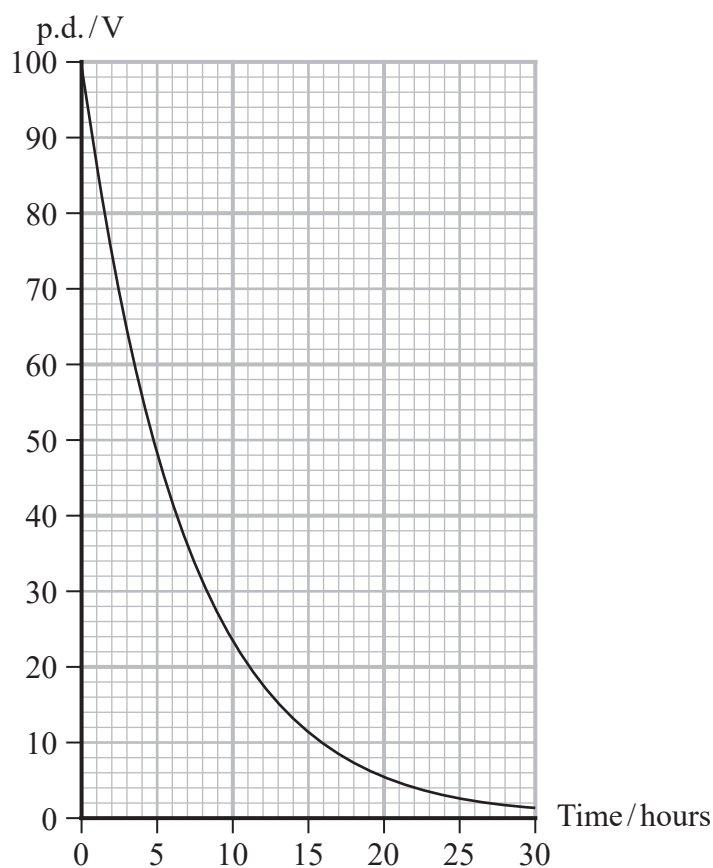

DO NOT WRITE IN THIS AREA

DO NOT WRITE IN THIS AREA

DO NOT WRITE IN THIS AREA

The insulator is a type of plastic and should have a resistivity greater than  $10^{14} \Omega \text{m}$ .

Deduce whether the plastic used in this capacitor has a resistivity greater than this value.

$$A = 5.6 \times 10^{-3} \text{m}^2$$

$$d = 0.6 \times 10^{-6} \text{m}$$

(5)

.....

.....

.....

.....

.....

.....

.....

.....

.....

.....

.....

.....

.....

.....

.....

.....

.....

.....

.....

.....

.....

.....

.....

.....

**(Total for Question 13 = 9 marks)**



- 14 The world solar challenge is set every two years, in Australia. The challenge is to complete a three thousand kilometre route with a vehicle powered only by the Sun.

Vehicles have their surfaces fitted with solar panels, as shown in the photograph.

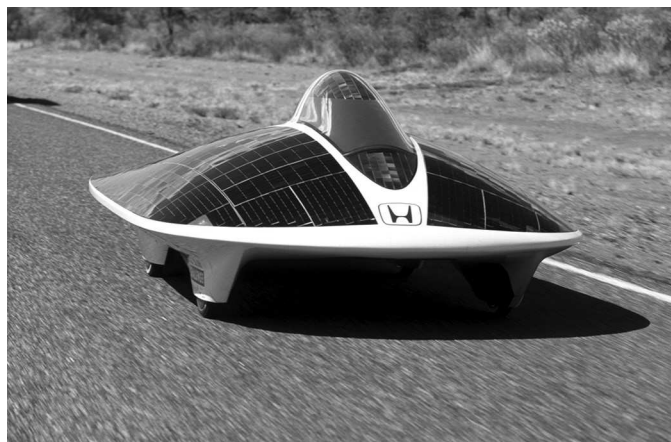

(Source: © LAURENT DOUEK/LOOK AT SCIENCES/SCIENCE PHOTO LIBRARY)

- (a) One of the solar panels has an e.m.f. of  $8.2\text{ V}$  when in sunlight. The terminal potential difference is  $5.5\text{ V}$  when a current of  $0.45\text{ A}$  is drawn from the solar panel.

Calculate the internal resistance of the solar panel in these conditions.

(3)

Internal resistance = .....

- (b) A bank of 380 of these solar panels is used to charge the battery in a vehicle. The panels are connected in parallel and the current provided by each panel is  $0.45\text{ A}$ . When fully charged, the energy stored in the battery is  $12\text{ kWh}$ .

Calculate the time, in hours, to fully charge this battery if the solar panels are in sunlight. Assume the efficiency of charging this battery is 100%.

(3)

Time = ..... hours





DO NOT WRITE IN THIS AREA

DO NOT WRITE IN THIS AREA

DO NOT WRITE IN THIS AREA

(c) The vehicle can reach a maximum speed of  $34 \text{ m s}^{-1}$  on flat ground. The electric motor used to move the vehicle has a power of  $4.5 \text{ kW}$ .

(i) Calculate the initial acceleration of the vehicle as it starts from rest.

mass of vehicle and driver =  $420 \text{ kg}$

(3)

Initial acceleration = .....

(ii) State one assumption made in this calculation.

(1)

(d) Solar power alone would not be suitable for a family car because it is not sunny all the time.

Give two further reasons why solar power alone would not be suitable.

(2)

**(Total for Question 14 = 12 marks)**



15 At the beginning of the 20th century, Rutherford carried out large-angle alpha particle scattering experiments using gold ( $^{197}_{79}\text{Au}$ ) foil.

The vast majority of the alpha particles went straight through the foil whilst a few were deflected straight back.

(a) Describe how the model of the atom changed, as a consequence of these experiments.

(4)

.....

.....

.....

.....

.....

.....

.....

.....

.....

.....

(b) In one experiment the alpha particles had an initial energy of 7.7 MeV.

Calculate the distance of closest approach of the alpha particles to the nucleus of a gold atom. Assume that the gold nucleus remains at rest.

(4)

.....

.....

.....

.....

.....

.....

.....

.....

.....

.....

Distance of closest approach = .....



- (c) Rutherford also carried out the experiment with aluminium ( $^{27}_{13}\text{Al}$ ) foil. The aluminium foil had the same thickness as the gold foil and the alpha particles had the same initial kinetic energy.

The following observations were made.

Observation 1:

The fraction of alpha particles scattered at any particular angle for aluminium foil was always much less than for gold foil.

Observation 2:

The alpha particles scattered from aluminium foil had less kinetic energy than the alpha particles scattered from gold foil.

Explain how these observations can be used to deduce how an aluminium nucleus compares to a gold nucleus.

(4)

.....

.....

.....

.....

.....

.....

.....

.....

.....

.....

**(Total for Question 15 = 12 marks)**



DO NOT WRITE IN THIS AREA

DO NOT WRITE IN THIS AREA

DO NOT WRITE IN THIS AREA

**BLANK PAGE**



DO NOT WRITE IN THIS AREA

DO NOT WRITE IN THIS AREA

DO NOT WRITE IN THIS AREA

16 The bubble chamber photograph shows tracks made by a proton and a pion. The proton and pion were both created by the decay of a lambda particle. No other particles were produced.

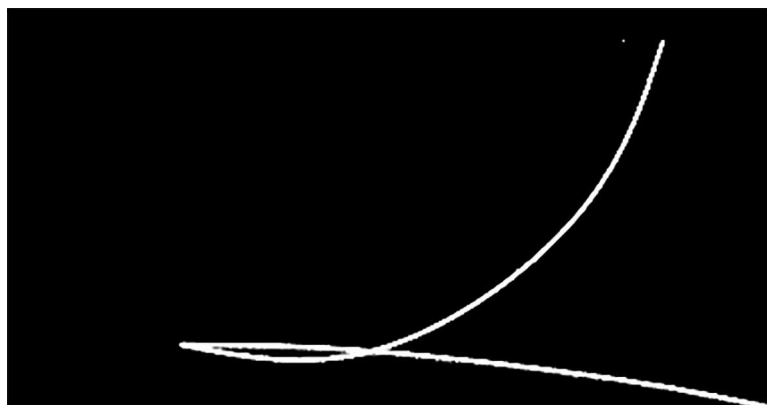

\*(a) Explain how observations and measurements from the photograph can be used to establish information about the lambda particle.

(6)

.....

.....

.....

.....

.....

.....

.....

.....

.....

.....

.....

.....

.....

.....

.....

.....

.....

.....

.....

.....

.....

.....

.....



(b) The lambda particle consists of up, down and strange quarks.

Explain how the conservation of charge, baryon number and lepton number apply to the decay of the lambda particle.

(3)

.....

.....

.....

.....

.....

.....

.....

(c) Write an equation to represent the decay of the lambda ( $\Lambda$ ) particle.

(1)

.....

.....

(d) The rest mass of the lambda particle is  $1115 \text{ MeV}/c^2$ .

(i) Calculate this mass in kg.

(3)

.....

.....

.....

.....

.....

.....

Mass = ..... kg



(ii) The rest mass of a proton is  $940 \text{ MeV}/c^2$ . The rest mass of a pion is  $140 \text{ MeV}/c^2$ .  
The kinetic energy of the lambda particle just before decay is  $4.95 \text{ GeV}$ .  
Calculate the total kinetic energy of the proton and pion in MeV.

(3)

.....

.....

.....

.....

.....

Total kinetic energy = ..... MeV

**(Total for Question 16 = 16 marks)**

DO NOT WRITE IN THIS AREA

DO NOT WRITE IN THIS AREA

DO NOT WRITE IN THIS AREA



17 The diagrams show the plan view and side view of a moving coil ammeter.

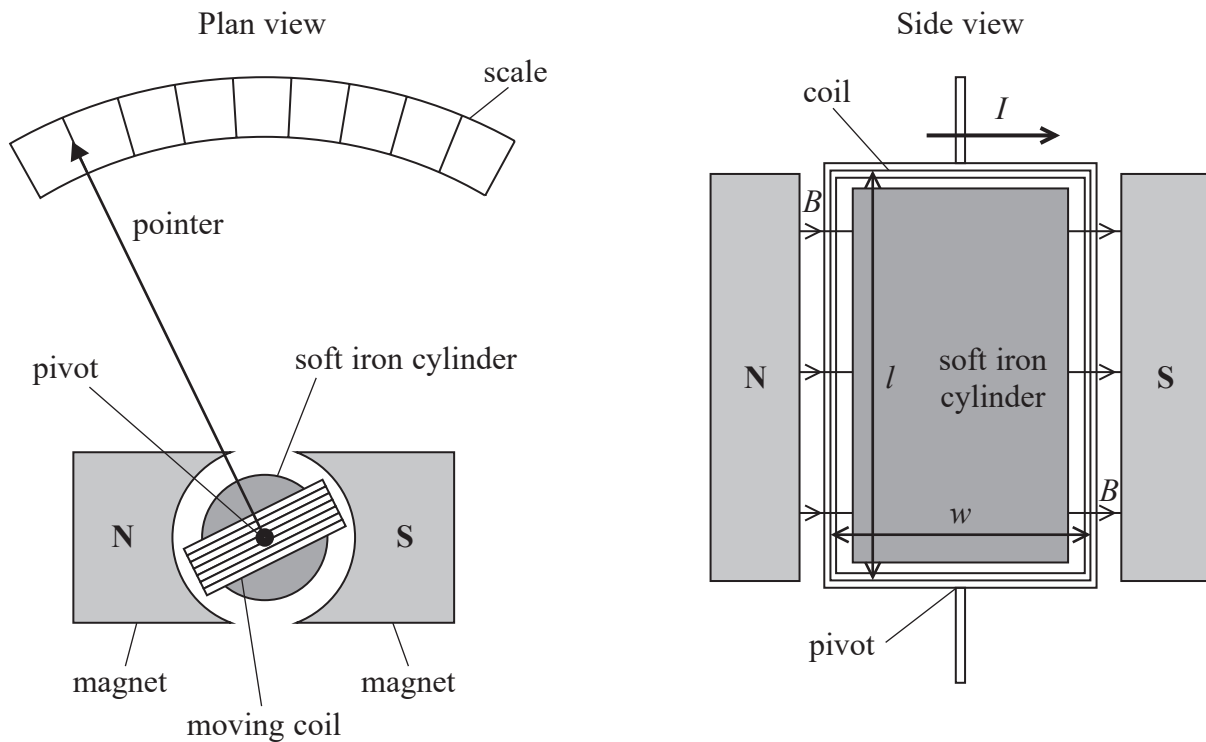

The fixed soft iron cylinder and magnets produce a uniform magnetic field of magnetic flux density  $B$ . The coil is able to rotate within this magnetic field. The coil has width  $w$  and length  $l$ . There is a current  $I$  in the coil in the direction shown in the side view diagram.

(a) (i) Explain which way the coil will rotate.

(2)

.....

.....

DO NOT WRITE IN THIS AREA

DO NOT WRITE IN THIS AREA

DO NOT WRITE IN THIS AREA





(ii) Show that the moment  $M$  on the coil about the pivot, due to the magnetic field, is given by

$$M = BAIN$$

where

$A$  is the cross-sectional area of the coil

$N$  is the number of turns of wire on the coil.

(4)

.....

.....

.....

.....

.....

.....

.....

.....

.....

.....

DO NOT WRITE IN THIS AREA

DO NOT WRITE IN THIS AREA

DO NOT WRITE IN THIS AREA



- (b) An ammeter of this type has a resistance of  $625\ \Omega$  and will measure a maximum current of  $1.6\ \text{mA}$ .

The ammeter can be adapted to measure potential difference by adding a resistor in series with the ammeter. This resistor is known as a multiplier.

The ammeter is adapted so that it can measure potential differences up to  $5.0\ \text{V}$  as shown.

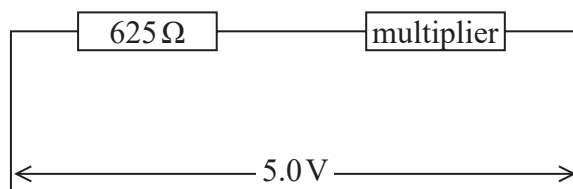

The following multipliers are available:

$200\ \Omega$        $2500\ \Omega$        $3125\ \Omega$        $3750\ \Omega$

Deduce which multiplier should be used.

(3)

.....

.....

.....

.....

.....

.....



DO NOT WRITE IN THIS AREA

DO NOT WRITE IN THIS AREA

DO NOT WRITE IN THIS AREA

(c) The coil within a very sensitive moving coil ammeter can be damaged when the ammeter is transported. The two ends of the coil are connected together when the ammeter is transported. This reduces the movement of the coil and makes it less likely to be damaged.

A student suggests that this is due to Faraday's law and Lenz's law.

Explain how these laws apply to this situation.

(4)

.....

.....

.....

.....

.....

.....

.....

.....

.....

.....

.....

**(Total for Question 17 = 13 marks)**

**TOTAL FOR PAPER = 90 MARKS**



### List of data, formulae and relationships

Acceleration of free fall	$g = 9.81 \text{ m s}^{-2}$	(close to Earth's surface)
Boltzmann constant	$k = 1.38 \times 10^{-23} \text{ J K}^{-1}$	
Coulomb law constant	$k = \frac{1}{4\pi\epsilon_0} = 8.99 \times 10^9 \text{ N m}^2 \text{ C}^{-2}$	
Electron charge	$e = -1.60 \times 10^{-19} \text{ C}$	
Electron mass	$m_e = 9.11 \times 10^{-31} \text{ kg}$	
Electronvolt	$1 \text{ eV} = 1.60 \times 10^{-19} \text{ J}$	
Gravitational constant	$G = 6.67 \times 10^{-11} \text{ N m}^2 \text{ kg}^{-2}$	
Gravitational field strength	$g = 9.81 \text{ N kg}^{-1}$	(close to Earth's surface)
Permittivity of free space	$\epsilon_0 = 8.85 \times 10^{-12} \text{ F m}^{-1}$	
Planck constant	$h = 6.63 \times 10^{-34} \text{ J s}$	
Proton mass	$m_p = 1.67 \times 10^{-27} \text{ kg}$	
Speed of light in a vacuum	$c = 3.00 \times 10^8 \text{ m s}^{-1}$	
Stefan-Boltzmann constant	$\sigma = 5.67 \times 10^{-8} \text{ W m}^{-2} \text{ K}^{-4}$	
Unified atomic mass unit	$u = 1.66 \times 10^{-27} \text{ kg}$	

#### Mechanics

Kinematic equations of motion

$$s = \frac{(u + v)t}{2}$$

$$v = u + at$$

$$s = ut + \frac{1}{2}at^2$$

$$v^2 = u^2 + 2as$$

Forces

$$\Sigma F = ma$$

$$g = \frac{F}{m}$$

$$W = mg$$

$$\text{moment of force} = Fx$$

Momentum

$$p = mv$$

Work, energy and power

$$\Delta W = F\Delta s$$

$$E_k = \frac{1}{2}mv^2$$

$$\Delta E_{\text{grav}} = mg\Delta h$$

$$P = \frac{E}{t}$$

$$P = \frac{W}{t}$$

$$\text{efficiency} = \frac{\text{useful energy output}}{\text{total energy input}}$$

$$\text{efficiency} = \frac{\text{useful power output}}{\text{total power input}}$$



## Electric circuits

Potential difference

$$V = \frac{W}{Q}$$

Resistance

$$R = \frac{V}{I}$$

Electrical power and energy

$$P = VI$$

$$P = I^2R$$

$$P = \frac{V^2}{R}$$

$$W = VIt$$

Resistivity

$$R = \frac{\rho l}{A}$$

Current

$$I = \frac{\Delta Q}{\Delta t}$$

$$I = nqvA$$

## Materials

Density

$$\rho = \frac{m}{V}$$

Stokes' law

$$F = 6\pi\eta rv$$

Hooke's law

$$\Delta F = k\Delta x$$

Young modulus

$$\text{Stress } \sigma = \frac{F}{A}$$

$$\text{Strain } \varepsilon = \frac{\Delta x}{x}$$

$$E = \frac{\sigma}{\varepsilon}$$

Elastic strain energy

$$\Delta E_{\text{el}} = \frac{1}{2}F\Delta x$$

## Waves and particle nature of light

Wave speed

$$v = f\lambda$$

Speed of a transverse wave on a string

$$v = \sqrt{\frac{T}{\mu}}$$

Intensity of radiation

$$I = \frac{P}{A}$$

Power of a lens

$$P = \frac{1}{f}$$

$$P = P_1 + P_2 + P_3 + \dots$$

Thin lens equation

$$\frac{1}{u} + \frac{1}{v} = \frac{1}{f}$$

Magnification for a lens

$$m = \frac{\text{image height}}{\text{object height}} = \frac{v}{u}$$

Diffraction grating

$$n\lambda = d \sin \theta$$

Refractive index

$$n_1 \sin \theta_1 = n_2 \sin \theta_2$$

$$n = \frac{c}{v}$$

Critical angle

$$\sin C = \frac{1}{n}$$

Photon model

$$E = hf$$

Einstein's photoelectric equation

$$hf = \phi + \frac{1}{2}mv_{\text{max}}^2$$

de Broglie wavelength

$$\lambda = \frac{h}{p}$$



## Further mechanics

Impulse

$$F\Delta t = \Delta p$$

Kinetic energy of a non-relativistic particle

$$E_k = \frac{p^2}{2m}$$

Motion in a circle

$$v = \omega r$$

$$T = \frac{2\pi}{\omega}$$

$$F = ma = \frac{mv^2}{r}$$

$$a = \frac{v^2}{r}$$

$$a = r\omega^2$$

$$F = mr\omega^2$$

## Fields

Coulomb's law

$$F = \frac{Q_1 Q_2}{4\pi\epsilon_0 r^2}$$

Electric field strength

$$E = \frac{F}{Q}$$

$$E = \frac{Q}{4\pi\epsilon_0 r^2}$$

$$E = \frac{V}{d}$$

Electric potential

$$V = \frac{Q}{4\pi\epsilon_0 r}$$

Capacitance

$$C = \frac{Q}{V}$$

Energy stored in a capacitor

$$W = \frac{1}{2}QV$$

$$W = \frac{1}{2}CV^2$$

$$W = \frac{1}{2}\frac{Q^2}{C}$$

Capacitor discharge

$$Q = Q_0 e^{-t/RC}$$

$$I = I_0 e^{-t/RC}$$

$$V = V_0 e^{-t/RC}$$

$$\ln Q = \ln Q_0 - \frac{t}{RC}$$

$$\ln I = \ln I_0 - \frac{t}{RC}$$

$$\ln V = \ln V_0 - \frac{t}{RC}$$

In a magnetic field

$$F = BIl \sin \theta$$

$$F = Bqv \sin \theta$$

Faraday's and Lenz's laws

$$\mathcal{E} = \frac{-d(N\phi)}{dt}$$

Root-mean-square values

$$V_{\text{rms}} = \frac{V_0}{\sqrt{2}}$$

$$I_{\text{rms}} = \frac{I_0}{\sqrt{2}}$$

DO NOT WRITE IN THIS AREA

DO NOT WRITE IN THIS AREA

DO NOT WRITE IN THIS AREA



## Nuclear and particle physics

In a magnetic field

$$r = \frac{p}{BQ}$$

## Thermodynamics

Heating

$$\Delta E = mc\Delta\theta$$

$$\Delta E = L\Delta m$$

Molecular kinetic theory

$$\frac{1}{2}m\langle c^2 \rangle = \frac{3}{2}kT$$

$$pV = \frac{1}{3}Nm\langle c^2 \rangle$$

Ideal gas equation

$$pV = NkT$$

Stefan-Boltzmann law

$$L = \sigma AT^4$$

$$L = 4\pi r^2\sigma T^4$$

Wien's law

$$\lambda_{\max} T = 2.898 \times 10^{-3} \text{ m K}$$

## Space

Intensity

$$I = \frac{L}{4\pi d^2}$$

Redshift of electromagnetic radiation

$$z = \frac{\Delta\lambda}{\lambda} \approx \frac{\Delta f}{f} \approx \frac{v}{c}$$

Cosmological expansion

$$v = H_0 d$$

## Nuclear radiation

Mass-energy

$$\Delta E = c^2\Delta m$$

Radioactive decay

$$A = \lambda N$$

$$\frac{dN}{dt} = -\lambda N$$

$$\lambda = \frac{\ln 2}{t_{1/2}}$$

$$N = N_0 e^{-\lambda t}$$

$$A = A_0 e^{-\lambda t}$$

## Gravitational fields

Gravitational force

$$F = \frac{Gm_1 m_2}{r^2}$$

Gravitational field strength

$$g = \frac{Gm}{r^2}$$

Gravitational potential

$$V_{\text{grav}} = \frac{-Gm}{r}$$

## Oscillations

Simple harmonic motion

$$F = -kx$$

$$a = -\omega^2 x$$

$$x = A \cos \omega t$$

$$v = -A\omega \sin \omega t$$

$$a = -A\omega^2 \cos \omega t$$

$$T = \frac{1}{f} = \frac{2\pi}{\omega}$$

$$\omega = 2\pi f$$

Simple harmonic oscillator

$$T = 2\pi \sqrt{\frac{m}{k}}$$

$$T = 2\pi \sqrt{\frac{l}{g}}$$



DO NOT WRITE IN THIS AREA

DO NOT WRITE IN THIS AREA

DO NOT WRITE IN THIS AREA

**BLANK PAGE**

