

## GCSE (9–1) Mathematics

J560/02 Paper 2 (Foundation Tier)

### Monday 6 November 2017 – Morning

Time allowed: 1 hour 30 minutes



**You may use:**

- Geometrical instruments
- Tracing paper

**Do not use:**

- A calculator



First name										
Last name										
Centre number						Candidate number				

### INSTRUCTIONS

- Use black ink. You may use an HB pencil for graphs and diagrams.
- Complete the boxes above with your name, centre number and candidate number.
- Answer **all** the questions.
- Read each question carefully before you start to write your answer.
- Where appropriate, your answers should be supported with working. Marks may be given for a correct method even if the answer is incorrect.
- Write your answer to each question in the space provided.
- If additional space is required, you should use the lined page(s) at the end of this booklet. The question number(s) must be clearly shown.
- Do **not** write in the barcodes.

### INFORMATION

- The total mark for this paper is **100**.
- The marks for each question are shown in brackets [ ].
- This document consists of **20** pages.

Answer **all** the questions.

- 1 A fair spinner has six sides.  
They are labelled 1, 1, 2, 4, 4, 5.

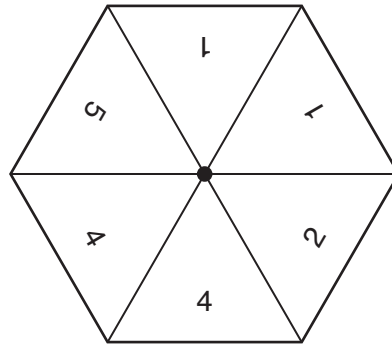

The diagram shows a probability scale.

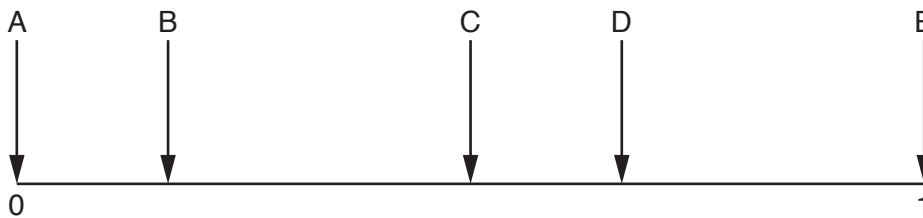

Which arrow shows the probability of

- (a) scoring a 2,

(a) ..... [1]

- (b) scoring a number less than 6,

(b) ..... [1]

- (c) scoring a 1 or a 4?

(c) ..... [1]

2 (a) Write down the number of lines of symmetry of this hexagon.

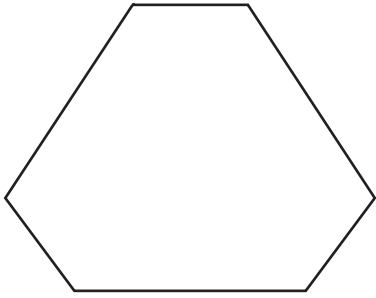

(a) ..... [1]

(b) Write down the order of rotation symmetry of this shape.

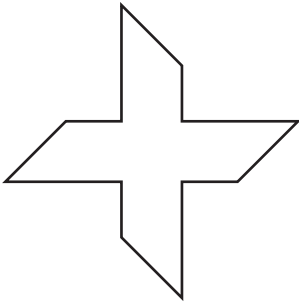

(b) ..... [1]

(c) A triangle has just one line of symmetry.

Write down the mathematical name of this type of triangle.

(c) ..... [1]

(d) Sara says

All parallelograms have 2 lines of symmetry and rotation symmetry of order 2.

Explain why Sara is not correct.

.....  
..... [1]

- 3 A 100g packet of tea costs £4.16.  
A 25g packet of the same tea costs £1.05.

Which packet is better value for money?  
Show how you decide.

..... [3]

- 4 One morning, **eight** buses arrive at a bus stop.  
The number of minutes late for each bus is shown below.

0   7   2   6   9   2   0   7

In the afternoon, two more buses arrive at the bus stop.

The median number of minutes late of **all ten** buses is 3.5.  
The mode number of minutes late of **all ten** buses is 0.

How many minutes late were the two afternoon buses?

..... and ..... minutes [3]

- 5 Write 0.26 as a fraction.  
Give your answer in its simplest form.

..... [2]

- 6 (a) Simplify fully.

(i)  $4(c + 2d) + 3(3c - 5d)$

(a)(i) ..... [3]

(ii)  $4a \times 5b$

(ii) ..... [1]

- (b) Factorise fully.

(i)  $6g + 8h$

(b)(i) ..... [1]

(ii)  $5x^2 - 15x$

(ii) ..... [2]

7 (a) Work out.

(i)  $1 + 4 \div 2$

(a)(i) ..... [1]

(ii)  $2 + 5 \times (8 - 4)$

(ii) ..... [1]

(b) Evaluate.

(i)  $2^5$

(b)(i) ..... [1]

(ii)  $\sqrt{400}$

(ii) ..... [1]

(c) Estimate the value of

$$\frac{23.1 \times 3.9}{8.12}$$

(c) ..... [3]

- 8 This is a rule to find the time, in minutes, needed to roast lamb.

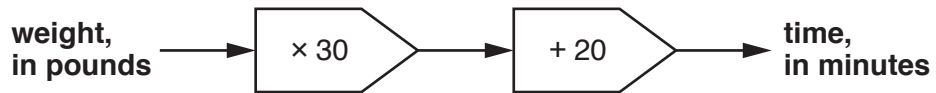

- (a) Use the rule to work out the time needed to roast a piece of lamb which weighs 4 pounds.

(a) ..... minutes [2]

- (b) A different piece of lamb takes 95 minutes to roast.

Use the rule to work out the weight of this piece of lamb.

(b) ..... pounds [2]

- 9 The diagram represents a rectangular garden of length 10 m and width 8 m. The flower bed is a triangle and the patio is a trapezium. The rest of the garden is lawn.

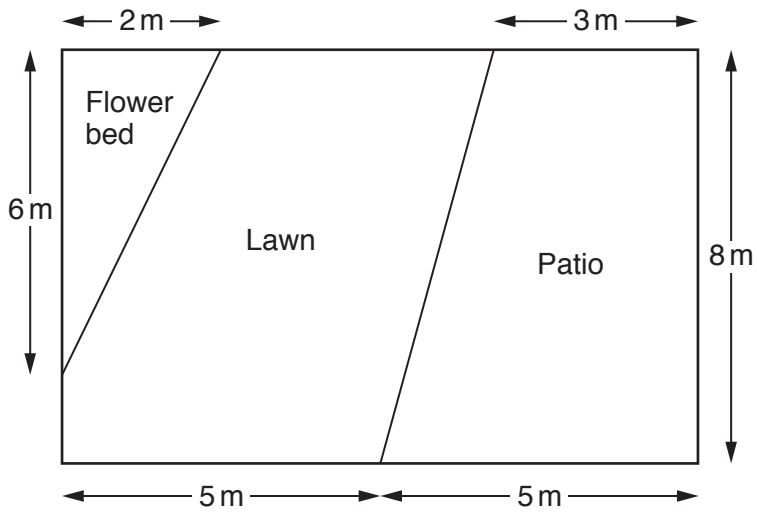

Not to scale

Work out the area of the lawn.

..... m<sup>2</sup> [6]



10 This pie chart shows how the employees of a business travel to work.

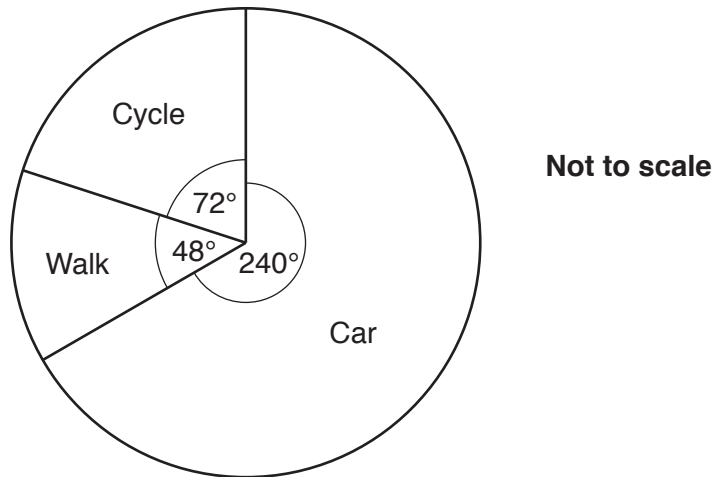

(a) Find the ratio of the number of employees who cycle to work to the number of employees who walk to work.  
Give your answer in its simplest form.

(a) ..... : ..... [2]

(b) 80 employees travel to work by car.

Work out the number of employees who cycle to work and the number of employees who walk to work.

(b) cycle .....  
walk ..... [3]

- 11 (a) Georgia is 4 feet 2 inches tall.  
There are 12 inches in a foot.

Use the conversion, 1 inch = 2.5 centimetres, to convert Georgia's height into metres.

(a) ..... m [3]

- (b) Owen weighs 6 stones 4 pounds.  
There are 14 pounds in a stone.

Use the conversion, 2.2 pounds = 1 kilogram, to convert Owen's weight into kilograms.

(b) ..... kg [3]

- 12 Jack carries out a survey in his school.  
He selects 50 students, at random, and asks them

Do you think that it is a good idea to have women-only railway carriages?

These are his results.

	Number of students
Yes	32
No	13
Don't know	5

- (a) What percentage of the students in Jack's survey answered 'Yes'?

(a) ..... % [3]

- (b) Jack says

*My survey shows that people in England think that it is a good idea to have women-only railway carriages.*

Explain why Jack may be wrong.

.....  
..... [1]

- 13 ABCD and PQRS are rectangles.  
O is the centre of both rectangles.

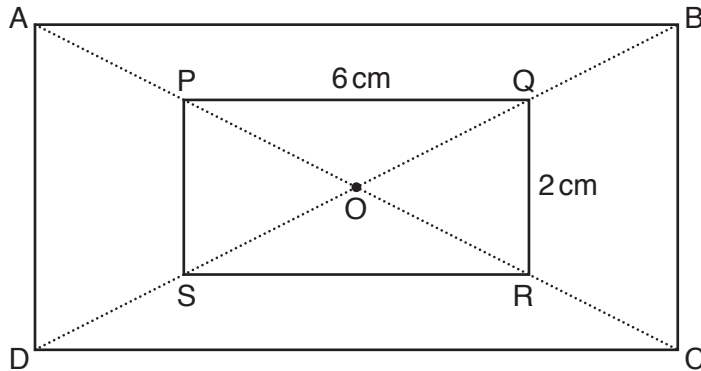

Not to scale

AC is a straight line passing through P, O and R.  
BD is a straight line passing through Q, O and S.

PQ = 6 cm and QR = 2 cm.

The perimeter of rectangle ABCD is 40 cm.

Work out the length and width of rectangle ABCD.

length = ..... cm

width = ..... cm [3]

- 14 Halina cycled from A to B at an average speed of 26 km per hour. She then cycled from B to C at an average speed of 20 km per hour.

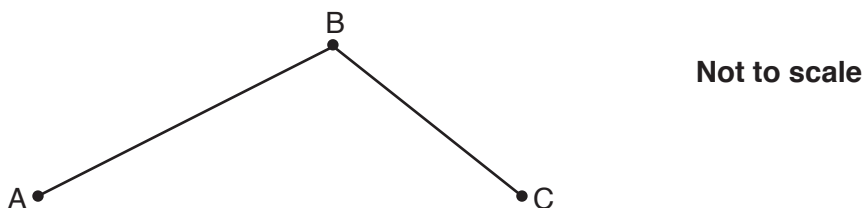

She left A at 10.00 am, did not stop at B and arrived at C at 3.00 pm.

- (a) It took Halina  $x$  hours to cycle from A to B.

- (i) Explain why the distance from A to B, in kilometres, is  $26x$ .

.....  
 ..... [1]

- (ii) Write down an expression, in terms of  $x$ , for the **time** taken to cycle from B to C.

(a)(ii) ..... hours [2]

- (iii) Hence show that the **distance** from B to C, in kilometres, is  $100 - 20x$ .

..... [1]

- (b) The **total distance** cycled by Halina from A to C is 118 km.

Find the distance from A to B.

(b) ..... km [4]

15 The diagram shows a circle, centre O.

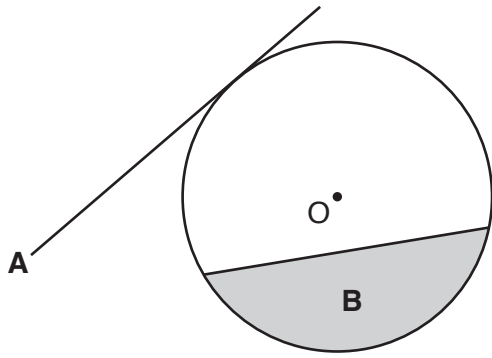

Write down the mathematical name of

(a) line A,

(a) ..... [1]

(b) shaded region B.

(b) ..... [1]

16 (a) Write the next term in each of these sequences.

(i) 1    1    2    3    5    8

(a)(i) ..... [1]

(ii) 2    4    8    16    32    64

(ii) ..... [1]

(b) Write an expression for the  $n$ th term of the sequence below.

15    12    9    6

(b) ..... [2]

17 Andrew is thinking of a number.

- It is between 1 and 150.
- It is one more than a square number.
- It is three less than a cube number.
- It is not a prime number.

What is Andrew's number?

You must show all your reasoning.

..... [4]

18 (a) Factorise.

$$x^2 - 43^2$$

(a) ..... [1]

(b) Calculate.

$$57^2 - 43^2$$

(b) ..... [2]

19 The angles in a triangle are in the ratio 1 : 2 : 3.

(a) Show that the triangle is a right-angled triangle.

[2]

(b) The hypotenuse of the triangle is 15 cm long.

Calculate the length of the shortest side in the triangle.

(b) ..... cm [4]

20 There is a total of 250 men, women and children on a train.

The ratio of men to women is 4 : 5.

The ratio of women to children is 10 : 7.

How many men are on the train?

..... [4]



- 21 (a) Noah starts to draw a tree diagram showing the outcomes of throwing a six when a fair dice is thrown twice.

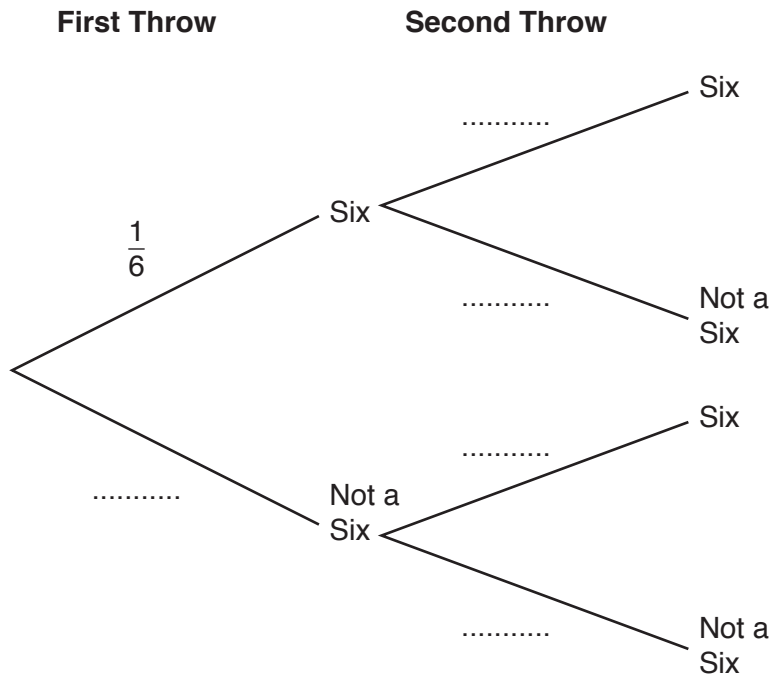

(i) Complete the tree diagram. [1]

(ii) What is the probability of throwing two sixes?

(a)(ii) ..... [2]

(b) Cara throws the same dice three times.

Show that the probability that Cara does not throw a six until her third throw is  $\frac{25}{216}$ . [2]

22 (a) Beth is given the following question.

Work out

$$4.1 \times 10^5 \times 3 \times 10^2.$$

Give your answer in standard form.

This is Beth's answer to the question.

$$12.3 \times 10^7$$

Explain why Beth's answer is incorrect.

.....  
..... [1]

(b) Show that

$$4.5 \times 10^2 + 7.3 \times 10^3 = 7.75 \times 10^3.$$

[2]

23 (a)  $n$  is an integer.

(i) Explain why  $2n + 1$  is an odd number.

.....  
..... [1]

(ii) Write down an algebraic expression for the next odd number after  $2n + 1$ .

(a)(ii) ..... [1]

(b) Use algebra to show that the sum of two consecutive odd numbers will always be a multiple of 4. [2]

END OF QUESTION PAPER

**ADDITIONAL ANSWER SPACE**

If additional space is required, you should use the following lined page(s). The question number(s) must be clearly shown in the margin(s).

A large rectangular area with a solid vertical line on the left side and horizontal dotted lines across the rest of the page, providing space for writing answers.



**Copyright Information**

OCR is committed to seeking permission to reproduce all third-party content that it uses in its assessment materials. OCR has attempted to identify and contact all copyright holders whose work is used in this paper. To avoid the issue of disclosure of answer-related information to candidates, all copyright acknowledgements are reproduced in the OCR Copyright Acknowledgements Booklet. This is produced for each series of examinations and is freely available to download from our public website ([www.ocr.org.uk](http://www.ocr.org.uk)) after the live examination series.

If OCR has unwittingly failed to correctly acknowledge or clear any third-party content in this assessment material, OCR will be happy to correct its mistake at the earliest possible opportunity.

For queries or further information please contact the Copyright Team, First Floor, 9 Hills Road, Cambridge CB2 1GE.

OCR is part of the Cambridge Assessment Group; Cambridge Assessment is the brand name of University of Cambridge Local Examinations Syndicate (UCLES), which is itself a department of the University of Cambridge.