

Thursday 8 June 2017 – Morning

GCSE MATHEMATICS B

J567/02 Paper 2 (Foundation Tier)

Candidates answer on the Question Paper.

OCR supplied materials:

None

Other materials required:

- Geometrical instruments
- Tracing paper (optional)
- Scientific or graphical calculator

Duration: 1 hour 30 minutes

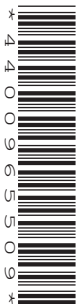

Candidate forename		Candidate surname	
--------------------	--	-------------------	--

Centre number						Candidate number				
---------------	--	--	--	--	--	------------------	--	--	--	--

INSTRUCTIONS TO CANDIDATES

- Write your name, centre number and candidate number in the boxes above. Please write clearly and in capital letters.
- Use black ink. HB pencil may be used for graphs and diagrams only.
- Answer **all** the questions.
- Read each question carefully. Make sure you know what you have to do before starting your answer.
- Your answers should be supported with appropriate working. Marks may be given for a correct method even if the answer is incorrect.
- Write your answer to each question in the space provided. Additional paper may be used if necessary but you must clearly show your candidate number, centre number and question number(s).
- Do **not** write in the barcodes.

INFORMATION FOR CANDIDATES

- The number of marks is given in brackets [] at the end of each question or part question.
- Use the π button on your calculator or take π to be 3.142 unless the question says otherwise.
- Your quality of written communication is assessed in questions marked with an asterisk (*).
- The total number of marks for this paper is **100**.
- This document consists of **24** pages. Any blank pages are indicated.

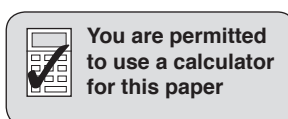

Formulae Sheet: Foundation Tier

Area of trapezium = $\frac{1}{2} (a + b)h$

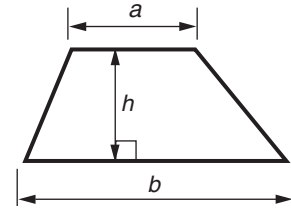

Volume of prism = (area of cross-section) \times length

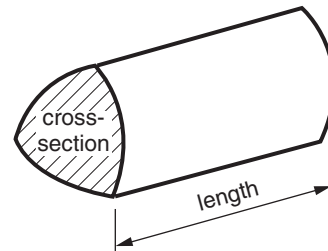

PLEASE DO NOT WRITE ON THIS PAGE

Answer **all** the questions.

1 (a) Here is a polygon.

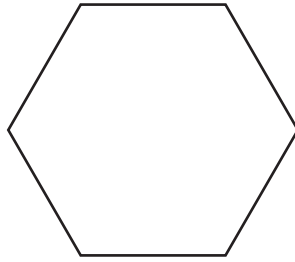

What is the mathematical name of this polygon?
Choose from the words in this box.

triangle pentagon hexagon octagon

(a) [1]

(b) Here is a quadrilateral.



What is the mathematical name of this quadrilateral?
Choose from the words in this box.

rectangle kite rhombus parallelogram

(b) [1]

(c) Here is a solid.

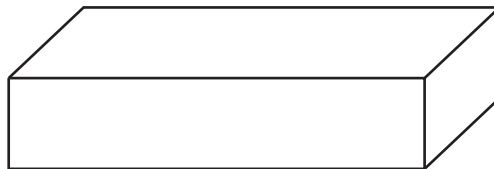

What is the mathematical name of this solid?
Choose from the words in this box.

cube cuboid cylinder sphere

(c) [1]

- 2 (a) Points A, B and C are marked on the grid below.

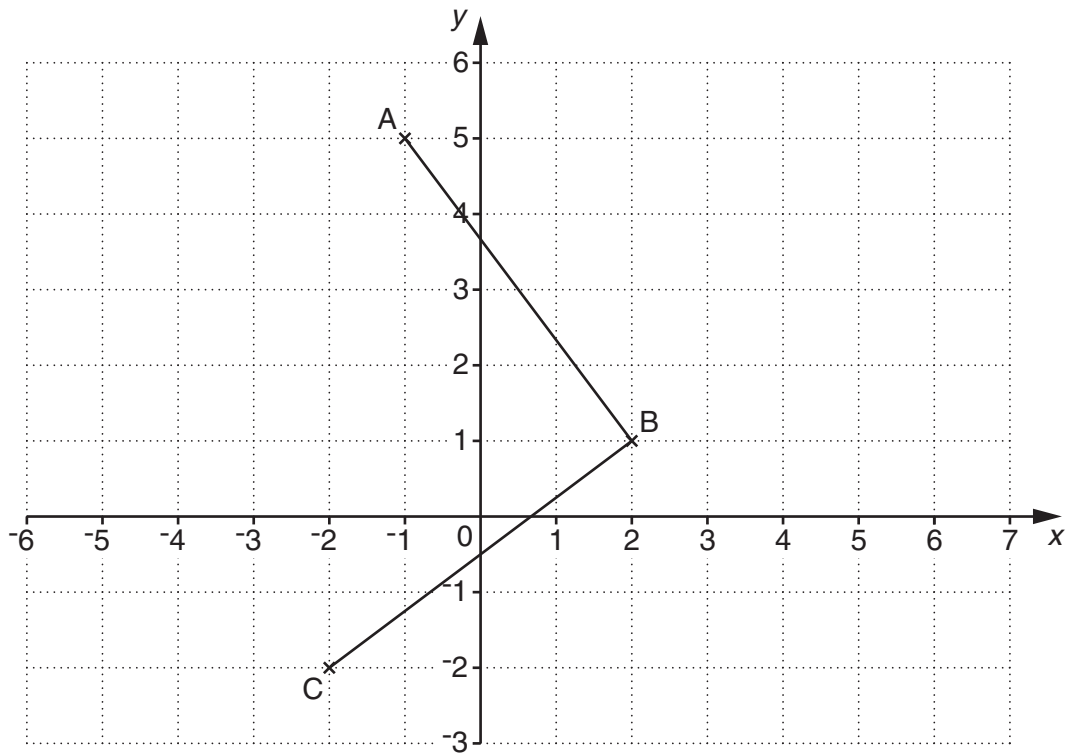

- (i) Write down the coordinates of point A and point B.

(a)(i) A (..... ,)

B (..... ,) [2]

- (ii) Plot the point D, with a cross, so that ABCD is a square. [1]

- (b) The coordinates of three corners of a rectangle are (73, 2), (76, 2) and (76, 4).

What are the coordinates of the other corner of this rectangle?

(b) (..... ,) [2]

3 (a) Work out.

(i) $4 + 5 \times 3$

(a)(i) [1]

(ii) $\frac{5.2 + 4.8}{2.5}$

(ii) [1]

(iii) $2^3 + 7^2$

(iii) [2]

(b) Find $\sqrt{30}$, giving your answer correct to 2 decimal places.

(b) [2]

(c) Work out the value of these expressions when $x = 12$.

(i) $5(x - 4)$

(c)(i) [1]

(ii) $9 - \frac{x}{3}$

(ii) [2]

4 Patrycja goes shopping in a supermarket.

- (a) She buys 500 grams of minced beef.
Minced beef costs £7.88 per kilogram.

How much does Patrycja spend on minced beef?

(a) £ [2]

- (b) She buys 150 grams of turkey breast.
Turkey breast costs £1.84 per 100 grams.

How much does Patrycja spend on turkey breast?

(b) £ [2]

- (c) Patrycja buys 12 bread rolls.
The bread rolls costs £4.44 altogether.

How much does one bread roll cost?

(c) £ [2]

- (d) The total bill for her shopping is £85.
73% of her bill is spent on food.

How much does Patrycja spend on food?

(d) £ [2]

5 (a) Shapes **A** and **B** are drawn on one-centimetre square grids.

(i)

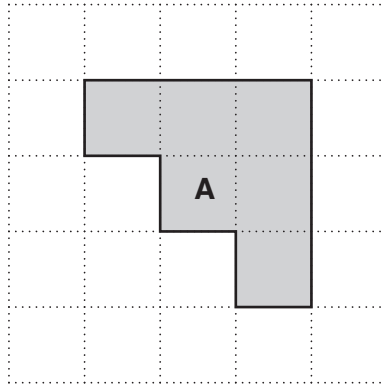

Work out the perimeter of shape **A**.

(a)(i) cm [1]

(ii)

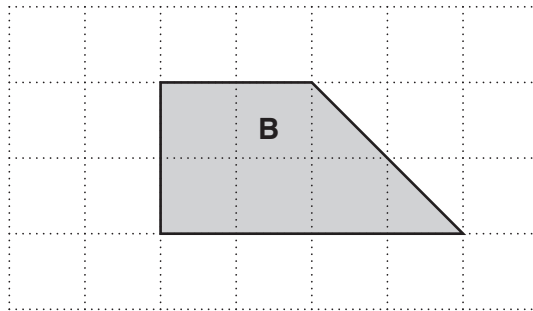

Work out the area of shape **B**.

(ii) cm² [1]

(b) Work out the area of this rectangle.



Not to scale

(b) cm² [2]

- 6 This shape is made of 4 small squares.



- (a) How many lines of symmetry does the shape have?

(a) [1]

- (b) Shade 2 more small squares on the edges of the shape below so that your shape has only **one** line of symmetry.

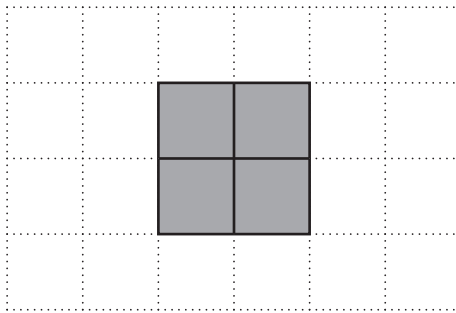

[1]

- (c) Shade 2 more small squares on the edges of the shape below so that your shape has only **one** line of symmetry and is **not** congruent to your shape in part (b).

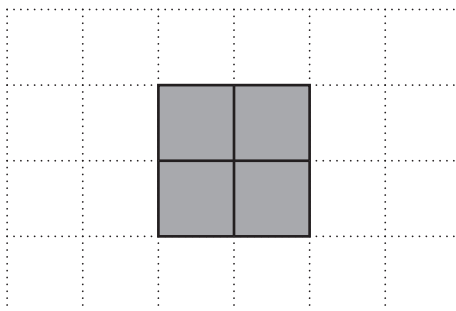

[1]

- (d) Shade 2 more small squares on the edges of the shape below so that your shape has rotation symmetry of order 2 and **no** lines of symmetry.

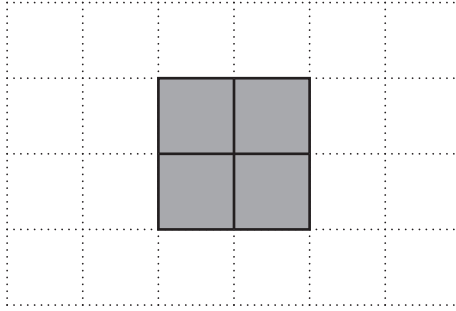

[1]

- (e) Shade 2 more small squares on the edges of the shape below so that your shape has rotation symmetry of order 2 and **two** lines of symmetry.

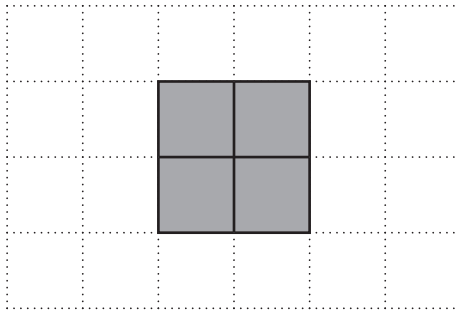

[1]

7 A company has 8 employees.
The annual wages of the employees, in thousands of pounds, are:

20 18 69 49 24 29 26 21

(a) Work out

(i) the median annual wage,

(a)(i) £ [2]

(ii) the mean annual wage.

(ii) £ [2]

(b) Which average better represents the annual wages of the employees, the median or the mean?

Give a reason for your answer.

..... because

.....

..... [1]

- 8 Asif goes for a walk.
 He leaves his home at 11:00 and walks until he stops to eat his lunch.
 He then returns home.
 This graph shows his journey.

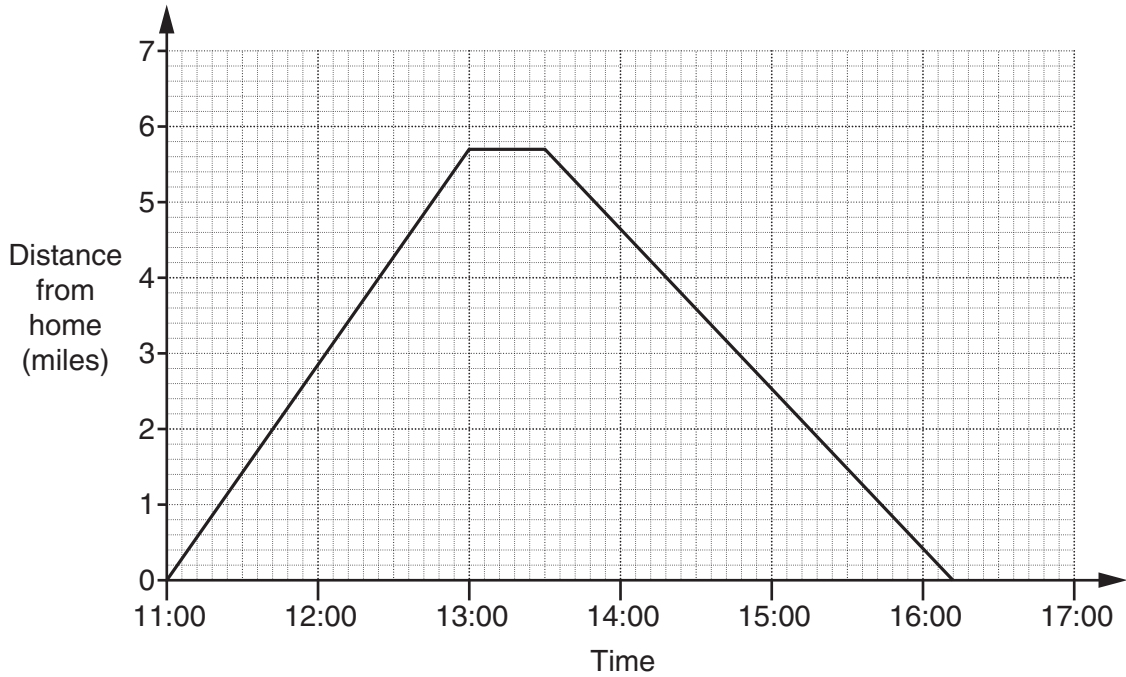

(a) How far does he walk altogether?

(a) miles [2]

(b) For how long does he stop for lunch?

(b) minutes [1]

(c) How long does it take Asif to walk home after eating his lunch?

(c) hours minutes [2]

- 9 (a) The first house on one side of a road is number 2.
The house numbers continue in the sequence 2, 4, 6, 8, ...

(i) What is the number of the 40th house on this side of the road?

(a)(i)[1]

(ii) The numbers of two houses, next door to each other, on this side of the road add up to 94.

What are the numbers of these two houses?

(ii) and[1]

- (b) The first house on the other side of this road is number 1.
The house numbers continue in the sequence 1, 3, 5, 7, ...

(i) What is the number of the 20th house on this side of the road?

(b)(i)[2]

(ii) The numbers of three houses, in a row, on this side of the road add up to 93.

What are the numbers of these three houses?

(ii) and and[1]

10 (a) Write down

(i) all the multiples of 7 that are smaller than 30,

(a)(i) [1]

(ii) all the multiples of 3 that are bigger than 1000 and smaller than 1010.

(ii) [1]

(b) (i) The number 44 has six factors.

Write down all the factors of 44.

(b)(i) [2]

(ii) Write down all the factors of 44 that are prime numbers.

(ii) [1]

(c) (i) Lloyd has a PIN number for his bank card.
It consists of 4 digits that satisfy the following:

- The digits in the number are all the same.
- The number is even.
- The number is a multiple of 3.

What is Lloyd's PIN number?

(c)(i) [1]

(ii) Marie has a PIN number for her bank card.
It consists of 4 digits that satisfy the following:

- The digits in the number are all different.
- The digits in the number add up to 6.
- The number is a factor of 9360.
- The number is a multiple of 5.

What is Marie's PIN number?

(ii) [1]

- 11 At lunch time in a school all pupils either have a school dinner, go home or bring a packed lunch. The school has recorded the choices of the pupils in Years 1 and 2 on this bar chart.

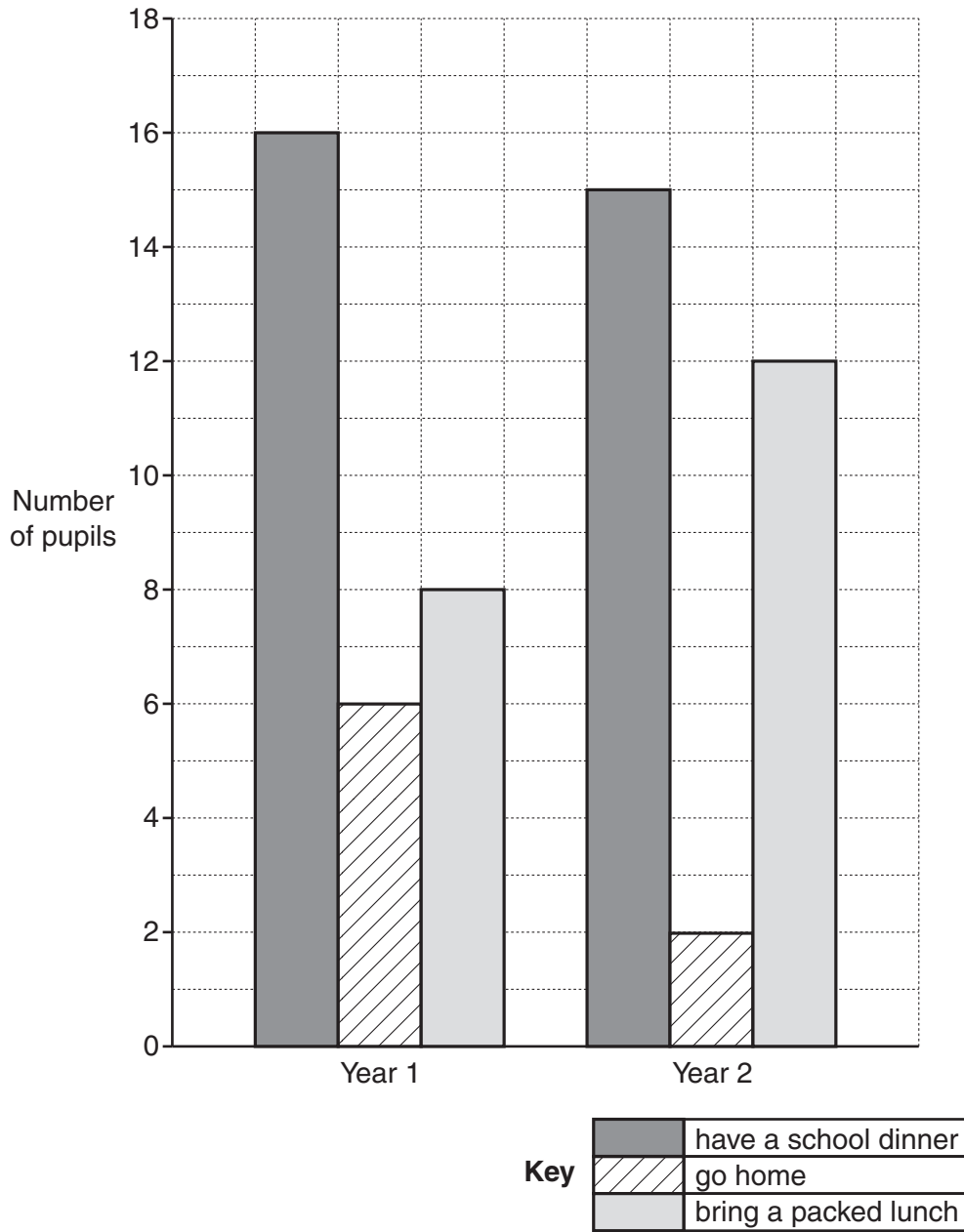

(a) How many Year 2 pupils have a school dinner?

(a) [1]

(b) How many **more** pupils bring a packed lunch in Year 2 than in Year 1?

(b) [1]

(c) How many pupils are there in Year 1 altogether?

(c) [2]

(d) What percentage of pupils in Year 1 go home for lunch?

(d) % [2]

12 (a) Write these fractions in order of size, smallest first.

$$\frac{3}{4} \quad \frac{3}{5} \quad \frac{7}{10} \quad \frac{13}{20}$$

Show your working.

(a) [2]
smallest

(b) (i) Find a fraction that is larger than $\frac{1}{5}$ and smaller than $\frac{2}{5}$.

(b)(i) [1]

(ii) Find a fraction that is larger than $\frac{5}{6}$ and smaller than $\frac{9}{10}$.

(ii) [2]

- 13 Work out the circumference of a circle of diameter 5m.

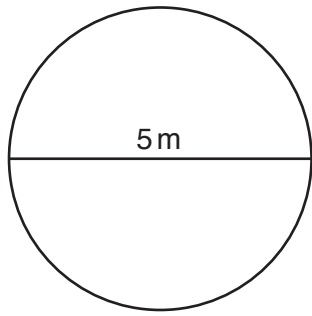

Not to scale

..... m [2]

14 (a) Here are three fair discs. Each disc is red on one side and blue on the other.

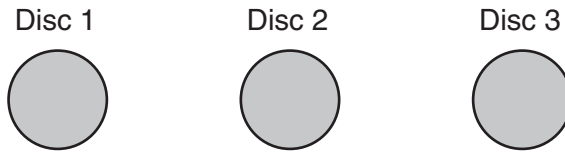

The three discs are thrown and the colours shown when they land are recorded.

(i) Complete the table below to show all the possible outcomes.

You may not need to use all the rows.

Disc 1	Disc 2	Disc 3
Red	Red	Red
Red	Red	Blue

[2]

(ii) What is the probability that the three discs all show the same colour?

(a)(ii) [2]

(iii) What is the probability that the three discs do **not** all show the same colour?

(iii) [1]

- (b) Two different fair discs are yellow on one side and green on the other.
The two discs are thrown.

What is the probability that the discs show the same colour when they land?

(b) [2]

- 15 The diagram shows a storage chest.
It is in the shape of a prism.

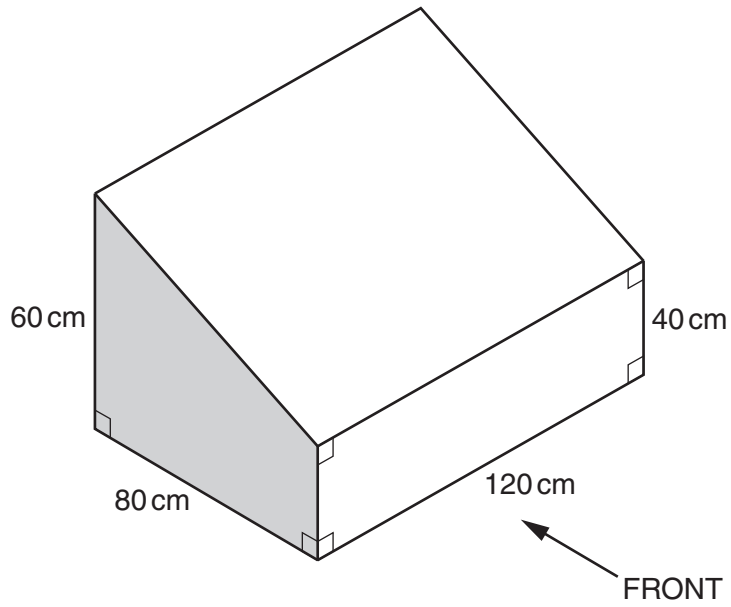

- (a) On the grid below, draw an accurate front elevation of the storage chest.
Use the scale **1 cm represents 20 cm**.

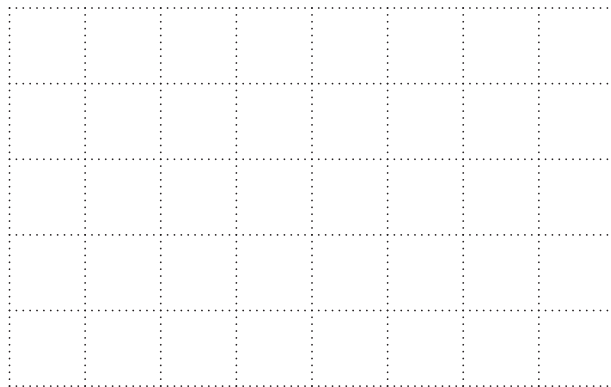

[2]

- (b) The shaded end of the chest is in the shape of a trapezium.

Calculate the volume, in cm^3 , of the chest.

(b) cm^3 [3]

16 (a) Find the cube root of 5832.

(a) [1]

(b) Find the reciprocal of 0.8.

(b) [1]

(c) Write 675 as the product of its prime factors.

(c) [2]

17 Alex goes for regular cycle rides.

(a) The scatter diagram shows the distance cycled and time taken for some of his rides.

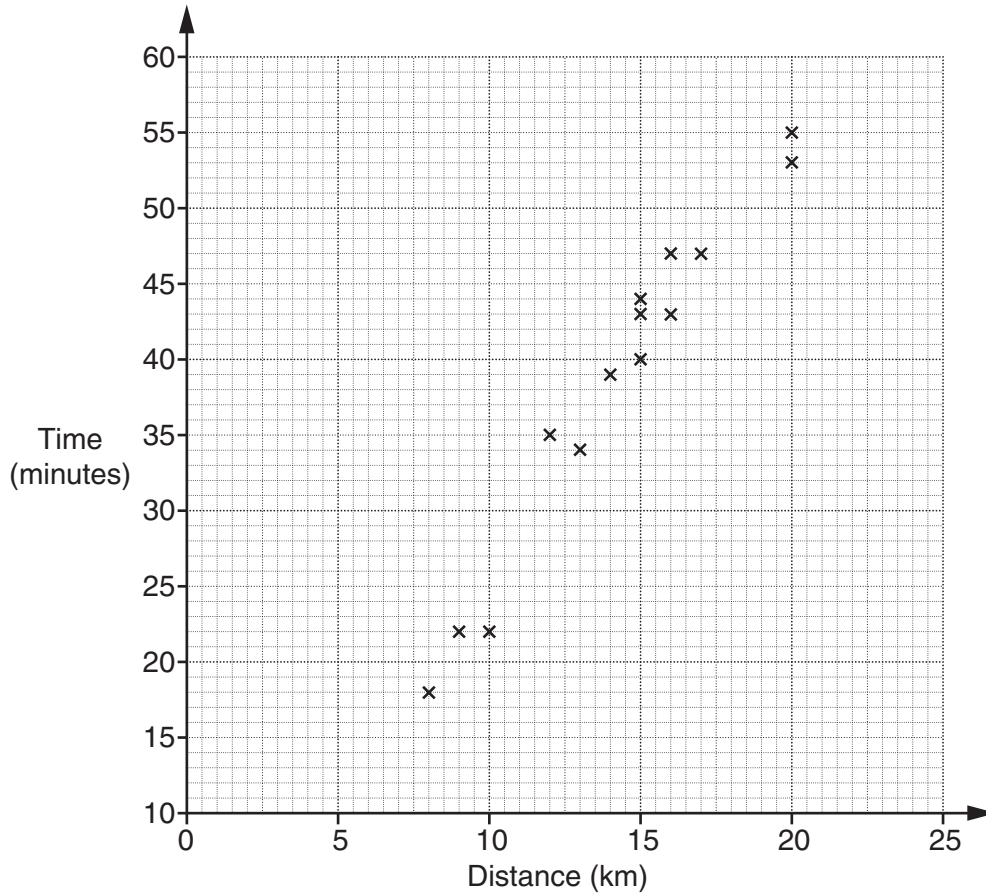

(i) Circle the **two** words below that describe the correlation shown.

positive negative zero weak strong moderate

[1]

(ii) Alex goes on another cycle ride.
It takes him 30 minutes.
He forgets to record the distance.

Draw a line of best fit on the scatter diagram and use it to estimate the distance Alex cycles.

(a)(ii) km [2]

(b) Alex goes on a 45 km cycle ride.
It takes him 2 hours 15 minutes.

Work out his average speed in kilometres per hour.

(b) km/h [3]

18 (a) Work out the value of $x^3 - 6x$ when $x = 3$.

(a) [1]

(b) The equation $x^3 - 6x = 20$ has a solution between 3 and 4.

Find this solution correct to 1 decimal place.

Show all your trials and their outcomes in the table below.

x		

(b) $x =$ [3]

- 19* A vertical wall 1.6m high is on horizontal ground.
A ladder of length 2.5m rests against the wall.
The ladder rests on the ground 0.7m from the wall.

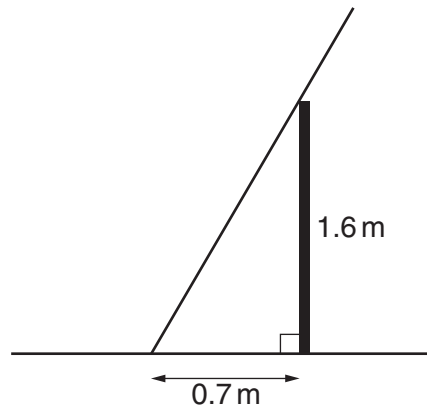

Not to scale

Work out the length of the ladder that extends above the wall.

..... [5]

END OF QUESTION PAPER

OCR
Oxford Cambridge and RSA

Copyright Information

OCR is committed to seeking permission to reproduce all third-party content that it uses in its assessment materials. OCR has attempted to identify and contact all copyright holders whose work is used in this paper. To avoid the issue of disclosure of answer-related information to candidates, all copyright acknowledgements are reproduced in the OCR Copyright Acknowledgements Booklet. This is produced for each series of examinations and is freely available to download from our public website (www.ocr.org.uk) after the live examination series. If OCR has unwittingly failed to correctly acknowledge or clear any third-party content in this assessment material, OCR will be happy to correct its mistake at the earliest possible opportunity.

For queries or further information please contact the Copyright Team, First Floor, 9 Hills Road, Cambridge CB2 1GE.

OCR is part of the Cambridge Assessment Group; Cambridge Assessment is the brand name of University of Cambridge Local Examinations Syndicate (UCLES), which is itself a department of the University of Cambridge.