

Write your name here

Surname

Other names

**Pearson Edexcel  
International GCSE**

Centre Number

--	--	--	--	--

Candidate Number

--	--	--	--

# Mathematics A

## Paper 2FR



**Foundation Tier**

Tuesday 19 January 2016 – Morning  
**Time: 2 hours**

Paper Reference

**4MA0/2FR**

**You must have:**

Ruler graduated in centimetres and millimetres, protractor, compasses, pen, HB pencil, eraser, calculator. Tracing paper may be used.

Total Marks

--

### Instructions

- Use **black** ink or ball-point pen.
- **Fill in the boxes** at the top of this page with your name, centre number and candidate number.
- Answer **all** questions.
- Without sufficient working, correct answers may be awarded no marks.
- Answer the questions in the spaces provided  
– *there may be more space than you need.*
- **Calculators may be used.**
- You must **NOT** write anything on the formulae page.  
Anything you write on the formulae page will gain NO credit.

### Information

- The total mark for this paper is 100.
- The marks for **each** question are shown in brackets  
– *use this as a guide as to how much time to spend on each question.*

### Advice

- Read each question carefully before you start to answer it.
- Check your answers if you have time at the end.

Turn over ►

P46915A

©2016 Pearson Education Ltd.

1/1/1/



**PEARSON**

International GCSE MATHEMATICS

FORMULAE SHEET – FOUNDATION TIER

Pythagoras' Theorem  
 $a^2 + b^2 = c^2$

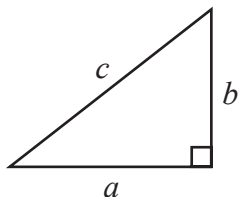

Area of a trapezium =  $\frac{1}{2}(a + b)h$

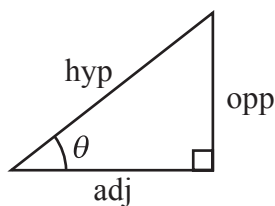
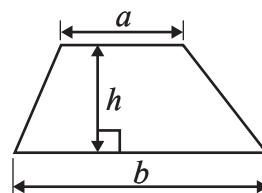

adj = hyp  $\times$  cos  $\theta$   
 opp = hyp  $\times$  sin  $\theta$   
 opp = adj  $\times$  tan  $\theta$

Volume of prism = area of cross section  $\times$  length

or  $\sin \theta = \frac{\text{opp}}{\text{hyp}}$

$\cos \theta = \frac{\text{adj}}{\text{hyp}}$

$\tan \theta = \frac{\text{opp}}{\text{adj}}$

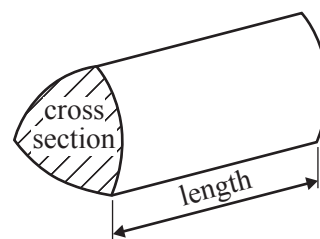

Circumference of circle =  $2\pi r$

Area of circle =  $\pi r^2$

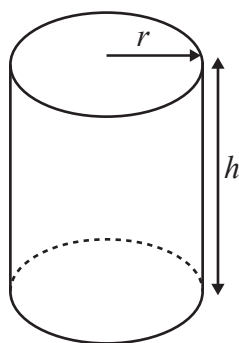

Volume of cylinder =  $\pi r^2 h$

Curved surface area of cylinder =  $2\pi r h$

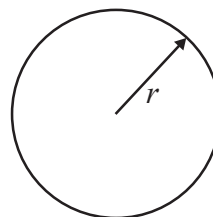

DO NOT WRITE IN THIS AREA

DO NOT WRITE IN THIS AREA

DO NOT WRITE IN THIS AREA



DO NOT WRITE IN THIS AREA

DO NOT WRITE IN THIS AREA

DO NOT WRITE IN THIS AREA

Answer ALL TWENTY FIVE questions.

Write your answers in the spaces provided.

You must write down all the stages in your working.

- 1 (a) Write these numbers in order of size.  
Start with the smallest number.

3            -2            -9            5            -11

.....  
(1)

- (b) Write these decimals in order of size.  
Start with the smallest decimal.

0.7            0.072            0.72            0.703            0.007

.....  
(1)

- (c) Write 0.7 as a percentage.

..... %  
(1)

- (d) Work out  $2^3 + \sqrt{144}$

.....  
(2)

(Total for Question 1 is 5 marks)



2 The table shows the heights of the six highest mountains in the world.

Mountain	Height in metres
Everest	8850
K2	8611
Kangchenjunga	8586
Lhotse I	8516
Makalu I	8463
Cho Oyu	8201

(a) Write the number 8201 in words.

.....  
(1)

(b) Write down the value of the 4 in the number 8463

.....  
(1)

(c) Which number in the table is a multiple of 10?

.....  
(1)

(d) Write the number 8586 correct to the nearest thousand.

.....  
(1)

(e) What is the difference between the height of Everest and the height of K2?

..... metres  
(1)

Two numbers in the table when written correct to the nearest hundred give 8500

(f) Write down these two numbers.

..... and .....  
(2)



(g) What is the number halfway between 8516 and 8586?

.....  
(2)

(h) Change 8850 metres to kilometres.

..... kilometres  
(1)

**(Total for Question 2 is 10 marks)**

3 (a) (i) Write the number on the dotted line to make the calculation correct.

$$283 + \dots\dots\dots = 576$$

(ii) Write the number on the dotted line to make the calculation correct.

$$50\% \text{ of } \dots\dots\dots = 9.7$$

(2)

(b) Write brackets in this calculation so that the answer is correct.

$$7 - 2 \times 5 + 7 = 60$$

(1)

**(Total for Question 3 is 3 marks)**



4

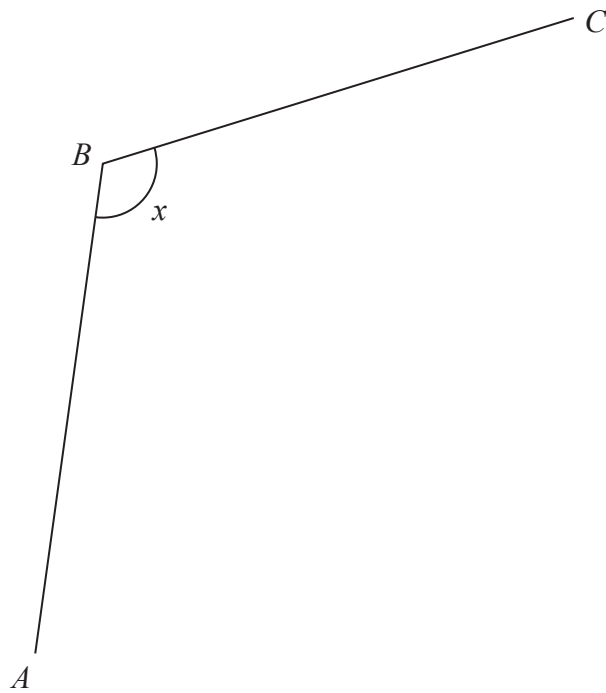

- (a) Measure the length of the line  $BC$ .  
Give your answer in millimetres.

..... mm  
(1)

- (b) Measure the size of angle  $x$ .

..... °  
(1)

acute	right	obtuse	reflex
-------	-------	--------	--------

- (c) Choose the word from the box that best describes angle  $x$  in the diagram.

.....  
(1)

**(Total for Question 4 is 3 marks)**

DO NOT WRITE IN THIS AREA

DO NOT WRITE IN THIS AREA

DO NOT WRITE IN THIS AREA

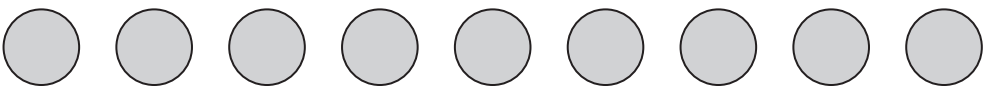
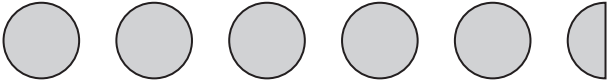
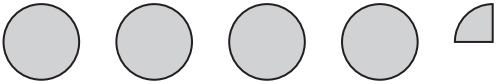
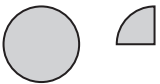
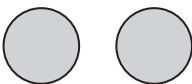

- 5 The pictogram gives information about the number of medals won by each of five countries in the 2014 Commonwealth Games.

<b>Nigeria</b>	
<b>Jamaica</b>	
<b>Singapore</b>	
<b>Cameroon</b>	
<b>Uganda</b>	
<b>Cyprus</b>	

 represents 4 medals

- (a) How many medals were won by Nigeria?

.....  
(1)

Jamaica won more medals than Cyprus.

- (b) How many more?

.....  
(2)

Cameroon won 7 medals in the 2014 Commonwealth Games.

- (c) Show this information on the pictogram.

(1)

**(Total for Question 5 is 4 marks)**



6 Here are six shapes made from centimetre squares.

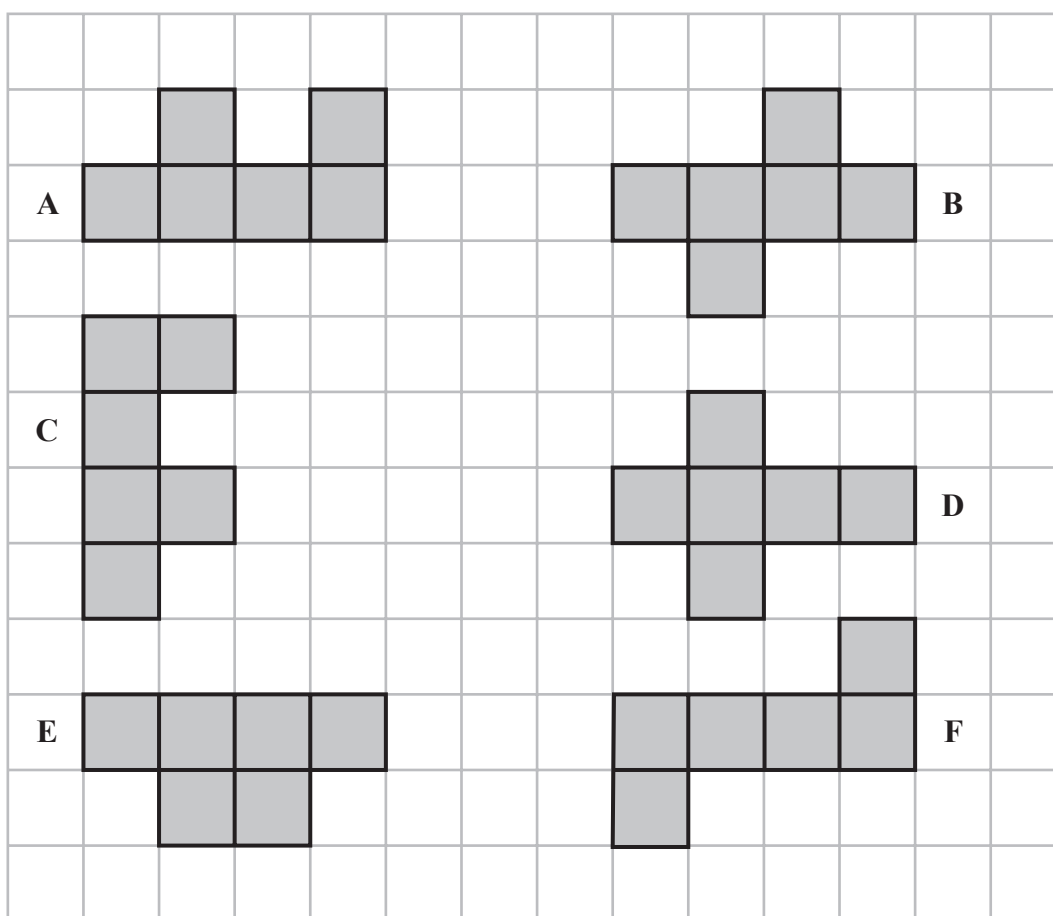

(a) Write down the letter of a shape with rotational symmetry of order 2

.....  
(1)

(b) How many lines of symmetry has shape **D**?

.....  
(1)

(c) Work out the perimeter of shape **E**.

..... cm  
(1)

Two of the shapes are congruent.

(d) Write down the letters of these two shapes.

..... and .....  
(1)

(Total for Question 6 is 4 marks)





DO NOT WRITE IN THIS AREA

DO NOT WRITE IN THIS AREA

DO NOT WRITE IN THIS AREA

7 A fair dice is thrown.

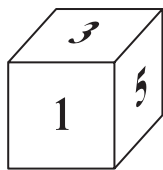

On the probability scale, mark with a cross (×) the probability that

- (i) the dice will land on an even number.  
Label this cross **E**.
- (ii) the dice will land on the number 5  
Label this cross **F**.
- (iii) the dice will land on a number less than 9  
Label this cross **G**.

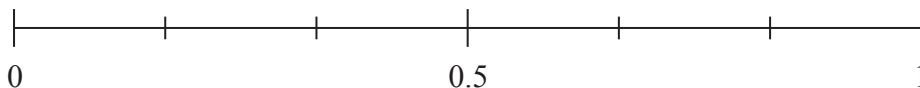

(Total for Question 7 is 3 marks)

8 Here is a number machine.



Complete the table.

Input	Output
4	30
7	
	48

(Total for Question 8 is 2 marks)



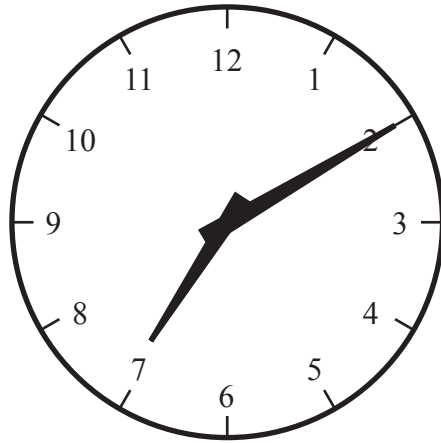

The clock face shows the time in the **evening** that James got home from work.

(a) Write this time using the 24-hour clock.

.....  
(1)

Later that evening James watched a film on TV.

The film started at 19 50

The film lasted 1 hour 25 minutes.

(b) At what time did the film end?

Give your answer using the 12-hour clock.

.....  
(2)

**(Total for Question 9 is 3 marks)**



10 The diagram shows a solid prism.

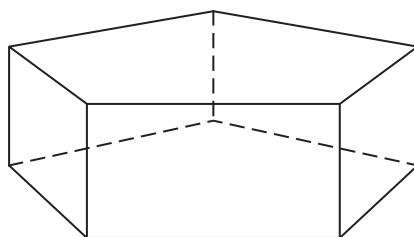

(a) How many edges has the prism?

.....  
(1)

(b) How many vertices has the prism?

.....  
(1)

(c) How many faces has the prism?

.....  
(1)

**(Total for Question 10 is 3 marks)**

11 There are 15 toy bricks in a bag.

There are   7 red bricks  
              3 green bricks  
              5 yellow bricks

Cristiano takes at random a brick from the bag.  
Write down the probability that Cristiano

(i) takes a red brick,

.....  
(1)

(ii) takes a blue brick,

.....  
(1)

(iii) does **not** take a green brick.

.....  
(1)

**(Total for Question 11 is 3 marks)**



12 You can use this graph to convert between euros (€) and Singapore Dollars (SGD).

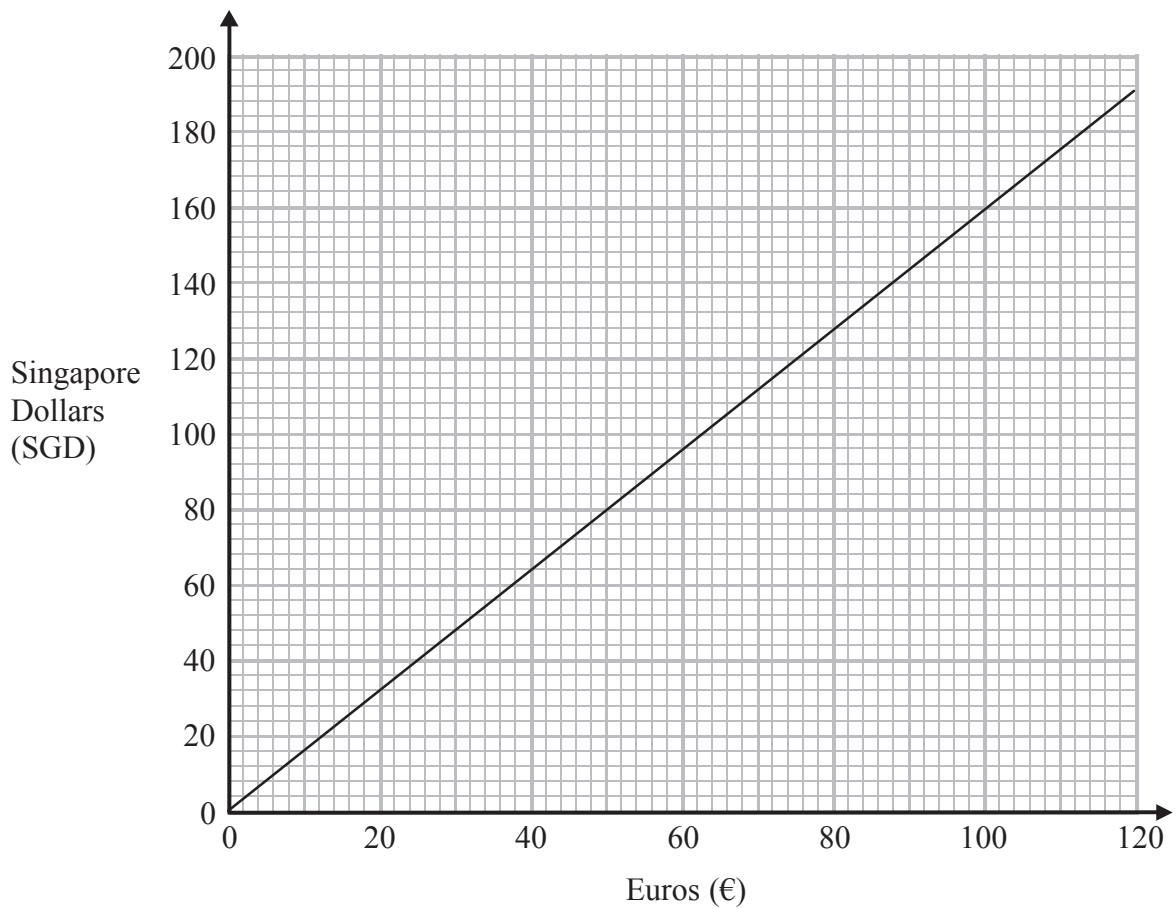

(a) Convert 50 euros to Singapore Dollars.

..... SGD  
(1)

(b) Convert 90 Singapore Dollars to euros.

..... euros  
(1)

(c) Convert 550 euros to Singapore Dollars.  
Show your working clearly.

..... SGD  
(2)

(Total for Question 12 is 4 marks)

DO NOT WRITE IN THIS AREA

DO NOT WRITE IN THIS AREA

DO NOT WRITE IN THIS AREA



13 Timothy buys

two loaves of bread at \$2.43 each

one jar of jam at \$2.29

$\frac{1}{2}$  kg of cheese at \$9.54 per kg

Timothy pays with a \$20 note.

How much change should Timothy get?

\$ .....

(Total for Question 13 is 3 marks)

14 The diagram shows a cuboid.

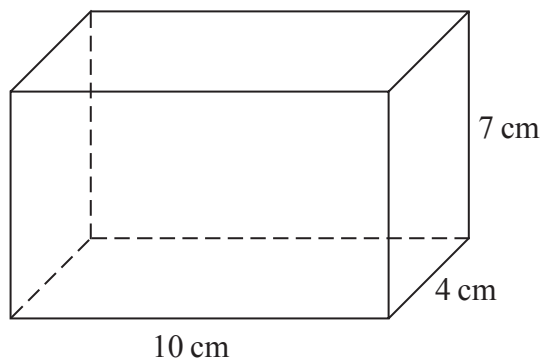

Diagram **NOT**  
accurately drawn

The cuboid has length 10 cm, width 4 cm and height 7 cm.

Work out the volume of the cuboid.

..... cm<sup>3</sup>

(Total for Question 14 is 2 marks)



15 (a) Simplify  $e + e + e + e$

.....  
(1)

(b) Simplify  $4c^2 + 3c^2 - 5c^2$

.....  
(1)

(c) Simplify  $7a + 5b - 2a - 9b$

.....  
(2)

(d) Simplify  $7p \times 2q$

.....  
(1)

(e) Simplify  $x^7 \times x^2$

.....  
(1)

(f) Simplify  $y^9 \div y^3$

.....  
(1)

(Total for Question 15 is 7 marks)



DO NOT WRITE IN THIS AREA

DO NOT WRITE IN THIS AREA

DO NOT WRITE IN THIS AREA

16 Ying eats some yoghurt.

Ying's recommended number of calories each day is 2500  
The yoghurt contains 175 calories.



- (a) Write 175 as a fraction of 2500  
Give your fraction in its simplest form.

.....  
(2)

The yoghurt contains 192 mg of calcium.  
This is 16% of the total amount of calcium that Ying should have each day.

- (b) Work out the total amount of calcium that Ying should have each day.

..... mg  
(3)

(Total for Question 16 is 5 marks)

17 (a) Expand and simplify  $4(2d + 3) - 2(3d - 5)$

.....  
(2)

$P = 5g + h^2$

- (b) Find the value of  $P$  when  $g = 3$  and  $h = -4$

$P =$  .....  
(2)

(Total for Question 17 is 4 marks)



18 Here are a rectangle and a square.

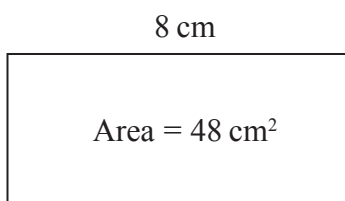

Diagram **NOT**  
accurately drawn

The rectangle has length 8 cm and area  $48 \text{ cm}^2$

The perimeter of the square is the same as the perimeter of the rectangle.

Calculate the area of the square.

.....  $\text{cm}^2$

(Total for Question 18 is 4 marks)

19 A plane flew from Bogotá to Quito.

The distance the plane flew was 725 km.

The time taken by the plane was 1 hour 24 minutes.

Work out the average speed of the plane.

Give your answer correct to 3 significant figures.

..... km/h

(Total for Question 19 is 3 marks)





DO NOT WRITE IN THIS AREA

DO NOT WRITE IN THIS AREA

DO NOT WRITE IN THIS AREA

20 Mr Rowland has a class of 30 students.  
He gave them 24 words to spell.  
The table shows information about the number of correct spellings for each student.

Number of correct spellings	Frequency
0 – 4	1
5 – 9	5
10 – 14	6
15 – 19	10
20 – 24	8

(a) Write down the modal class.

.....  
(1)

(b) Work out an estimate for the mean number of correct spellings.  
Give your answer to 1 decimal place.

.....  
(4)

(Total for Question 20 is 5 marks)

21 Show that  $\frac{3}{4} + \frac{4}{5} = 1\frac{11}{20}$

(Total for Question 21 is 2 marks)



22 Here is a list of ingredients needed to make 16 cookies.

Ingredients for 16 cookies
120 g butter
150 g sugar
240 g flour
170 g chocolate
1 egg

Max wants to make 40 cookies.

(a) How much flour does Max need?

..... 00  
(2)

Abby made cookies to sell at a school fair.  
She used 600 g of butter.

(b) How many cookies did she make?

.....  
(2)

(c) Find the ratio of the weight of sugar to the weight of flour in the list of ingredients.  
Give your answer in the form 1:  $n$

1 : .....  
(2)

(Total for Question 22 is 6 marks)



23

DO NOT WRITE IN THIS AREA

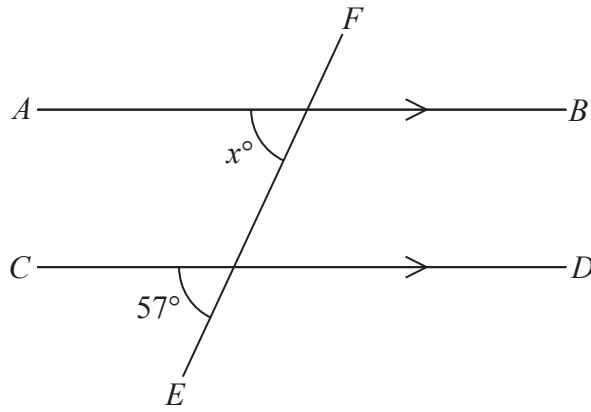

Diagram **NOT** accurately drawn

$AB$  is parallel to  $CD$   
 $EF$  is a straight line.

(a) (i) Find the value of  $x$

$x =$  .....

(ii) Give a reason for your answer.

(2)

Here is a pentagon.

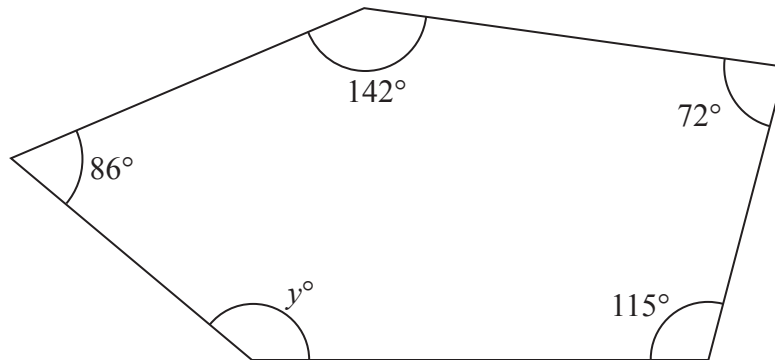

Diagram **NOT** accurately drawn

(b) Work out the value of  $y$ .

$y =$  .....

(3)

(Total for Question 23 is 5 marks)

DO NOT WRITE IN THIS AREA

DO NOT WRITE IN THIS AREA

Turn over for Questions 24 and 25.



24 (a) Solve  $9y - 3 = 5y + 2$

$$y = \dots\dots\dots (2)$$

(b) Solve  $\frac{7x - 1}{5} = x$

Show clear algebraic working.

$$x = \dots\dots\dots (3)$$

(Total for Question 24 is 5 marks)

25  $\mathcal{E} = \{\text{whole numbers}\}$

$A = \{\text{factors of } 100\}$

$B = \{\text{multiples of } 5\}$

List the members of the set  $A \cap B$

(Total for Question 25 is 2 marks)

TOTAL FOR PAPER IS 100 MARKS

