

Tuesday 18 June 2013 – Morning

**GCSE GATEWAY SCIENCE
PHYSICS B**

B752/02 Physics modules P4, P5, P6 (Higher Tier)

Candidates answer on the Question Paper.
A calculator may be used for this paper.

OCR supplied materials:
None

Other materials required:

- Pencil
- Ruler (cm/mm)

Duration: 1 hour 30 minutes



Candidate forename		Candidate surname	
-----------------------	--	----------------------	--

Centre number						Candidate number				
---------------	--	--	--	--	--	------------------	--	--	--	--

INSTRUCTIONS TO CANDIDATES

- Write your name, centre number and candidate number in the boxes above. Please write clearly and in capital letters.
- Use black ink. HB pencil may be used for graphs and diagrams only.
- Answer **all** the questions.
- Read each question carefully. Make sure you know what you have to do before starting your answer.
- Write your answer to each question in the space provided. Additional paper may be used if necessary but you must clearly show your candidate number, centre number and question number(s).
- Do **not** write in the bar codes.

INFORMATION FOR CANDIDATES

- Your quality of written communication is assessed in questions marked with a pencil (✎).
- A list of equations can be found on page 2.
- The number of marks is given in brackets [] at the end of each question or part question.
- The total number of marks for this paper is **85**.
- This document consists of **32** pages. Any blank pages are indicated.

EQUATIONS

$$\text{energy} = \text{mass} \times \text{specific heat capacity} \times \text{temperature change}$$

$$\text{energy} = \text{mass} \times \text{specific latent heat}$$

$$\text{efficiency} = \frac{\text{useful energy output} (\times 100\%)}{\text{total energy input}}$$

$$\text{wave speed} = \text{frequency} \times \text{wavelength}$$

$$\text{power} = \text{voltage} \times \text{current}$$

$$\text{energy supplied} = \text{power} \times \text{time}$$

$$\text{average speed} = \frac{\text{distance}}{\text{time}}$$

$$\text{distance} = \text{average speed} \times \text{time}$$

$$s = \frac{(u + v)}{2} \times t$$

$$\text{acceleration} = \frac{\text{change in speed}}{\text{time taken}}$$

$$\text{force} = \text{mass} \times \text{acceleration}$$

$$\text{weight} = \text{mass} \times \text{gravitational field strength}$$

$$\text{work done} = \text{force} \times \text{distance}$$

$$\text{power} = \frac{\text{work done}}{\text{time}}$$

$$\text{power} = \text{force} \times \text{speed}$$

$$\text{KE} = \frac{1}{2}mv^2$$

$$\text{momentum} = \text{mass} \times \text{velocity}$$

$$\text{force} = \frac{\text{change in momentum}}{\text{time}}$$

$$\text{GPE} = mgh$$

$$\text{resistance} = \frac{\text{voltage}}{\text{current}}$$

$$v = u + at$$

$$v^2 = u^2 + 2as$$

$$s = ut + \frac{1}{2}at^2$$

$$m_1u_1 + m_2u_2 = (m_1 + m_2)v$$

$$\text{refractive index} = \frac{\text{speed of light in vacuum}}{\text{speed of light in medium}}$$

$$\text{magnification} = \frac{\text{image size}}{\text{object size}}$$

$$l_e = l_b + l_c$$

$$\frac{\text{voltage across primary coil}}{\text{voltage across secondary coil}} =$$

$$\frac{\text{number of primary turns}}{\text{number of secondary turns}}$$

$$\text{power loss} = (\text{current})^2 \times \text{resistance}$$

$$V_p I_p = V_s I_s$$

BLANK PAGE

Question 1 begins on page 4

PLEASE DO NOT WRITE ON THIS PAGE

Answer **all** the questions.

SECTION A – Module P4

1 Ultrasound is a longitudinal wave.

(a) Look at the diagram of an ultrasound wave in air.

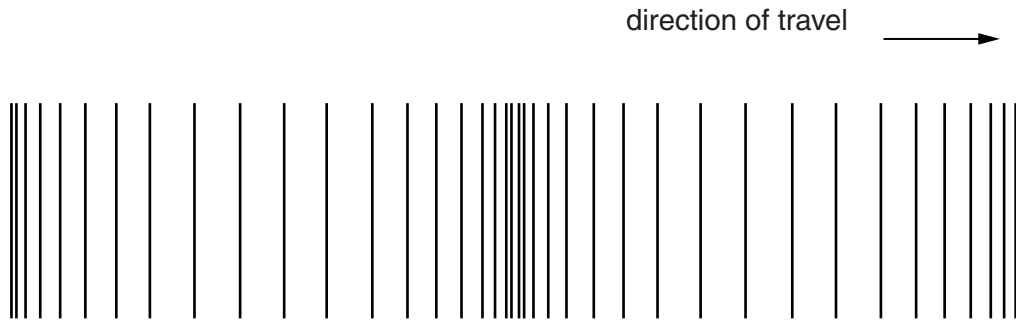

Use the diagram to describe the differences between a region of compression and a region of rarefaction.

.....

.....

.....

..... [2]

(b) Ultrasound can be used to scan the kidney and to break down kidney stones.

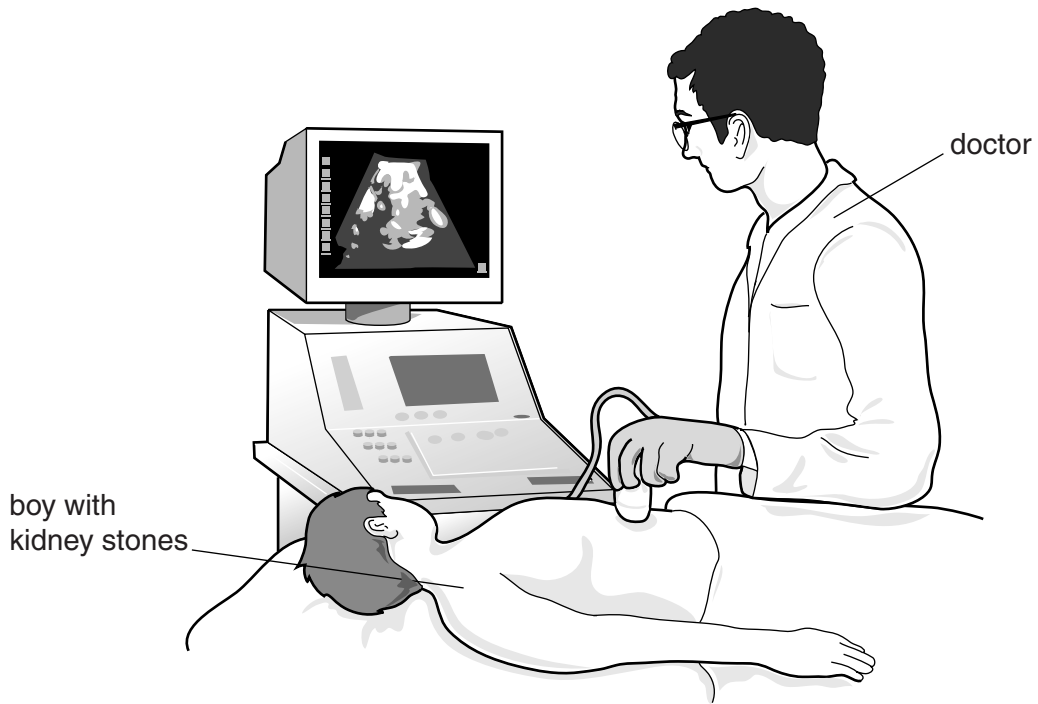

(i) Explain how ultrasound breaks down kidney stones.

.....
..... [1]

(ii) Explain why ultrasound is used rather than X-rays to scan the kidney.

.....
..... [1]

[Total: 4]

(b) Radioactive substances decay naturally.

Look at the information about two different radioactive substances.

Time in hours	Activity of substance X in counts per second	Activity of substance Y in counts per second
0	8070	12810
1	6801	6385
2	5697	3221
3	4808	1594
4	4027	807
5	3390	392
6	2861	197
7	2410	102
8	2008	51

Use the data in the table to compare the half-life of substance X and the half-life of substance Y.

.....

.....

.....

..... [2]

[Total: 8]

3 Ronin and Kiri use an electric circuit to investigate the resistance of a thin wire.

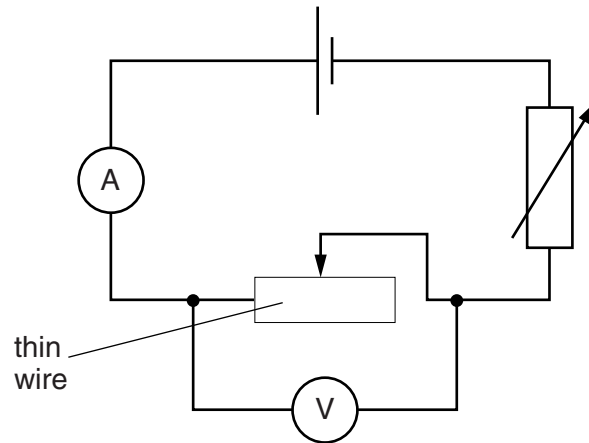

(a) Ronin changes the length of the wire. He calculates the resistance for each length.

He plots a graph of his results.

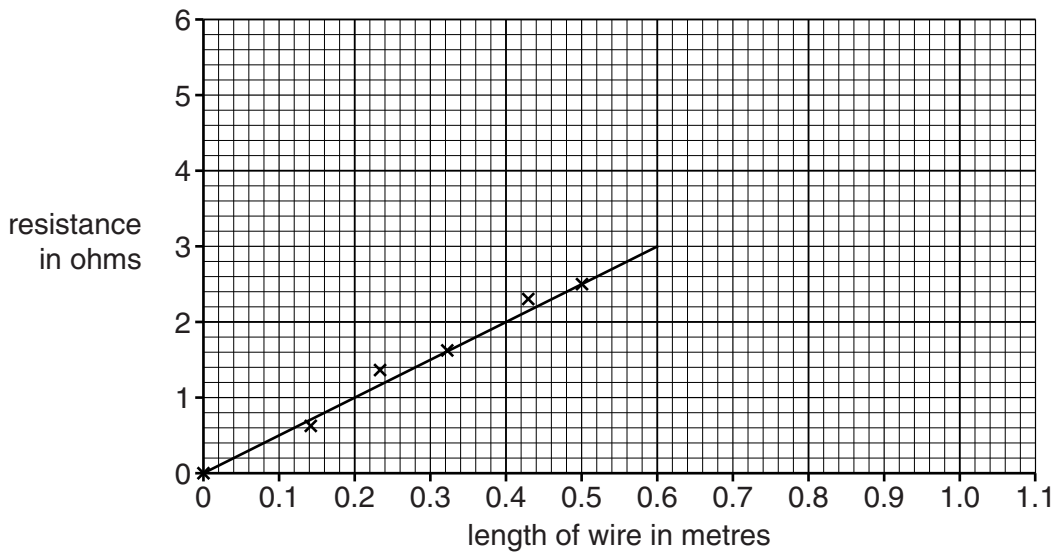

(i) Calculate the current for a **1.0 m** length of wire, when the voltage across it is 0.75V.

.....

.....

.....

current amps [3]

(ii) The voltage across the thin wire is kept fixed at 0.75V.

Describe the relationship between the current in the thin wire and its length.

.....
..... [1]

(b) Kiri repeats the investigation with a **thinner** wire.

She keeps all the other factors the same.

Draw a line on the graph to show how the resistance of the thinner wire changes as the length increases. [1]

[Total: 5]

Question 4 begins on page 10

4 This question is about nuclear energy.

(a) Complete the crossword.

Across

3 In stars, fusion happens at extremely high _ _ _ _ **e** _ _ _ _ _ **s**.

Down

1 Nuclei of hydrogen isotopes undergo fusion to form _ _ _ _ _ nuclei.

2 Scientists stop nuclear fission reactions going out of control in a reactor by absorbing some of the _ **e** _ _ _ _ _.

4 Scientists stop nuclear reactions going out of control by placing metal _ _ _ **s** in the reactor.

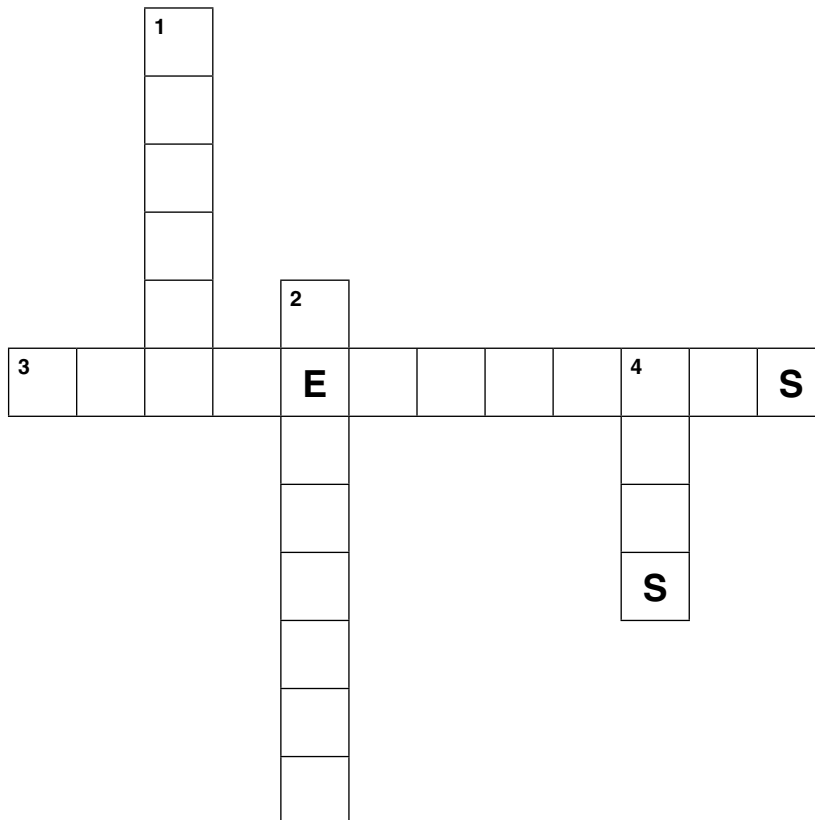

[2]

(b) Andrea Rossi **claims** to have invented an 'energy catalyser cold fusion system'.

He demonstrated the system in January 2011 by passing hydrogen over a secret catalyst. It appeared to show that an input of a few hundred kilowatts produced an output of a few thousand kilowatts.

Some scientists believe there is a nuclear reaction taking place because of the large amounts of extra energy produced.

Suggest why other scientists might **not** accept this claim.

.....

.....

.....

.....

.....

..... [2]

[Total: 4]

Question 5 begins on page 12

5 Tanida jumps up and down on a trampoline.

The jumping surface of the trampoline is an insulating material.
Tanida is wearing synthetic socks.



(a) When Tanida gets off the trampoline she gets an electrostatic shock as she touches the ground.

Use ideas about electron transfer to explain why this happens.

.....

.....

.....

.....

..... [2]

(b) Anti-static sprays reduce the problem of static electricity on the trampoline.

Explain how.

.....

.....

..... [2]

[Total: 4]

13
BLANK PAGE

SECTION B begins on page 14

PLEASE DO NOT WRITE ON THIS PAGE

SECTION B – Module P5

- 6 Rockets use hot gases to make them move.

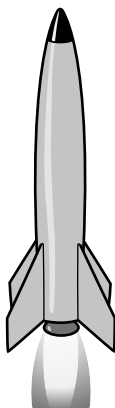

Look at the diagram of a simple rocket.

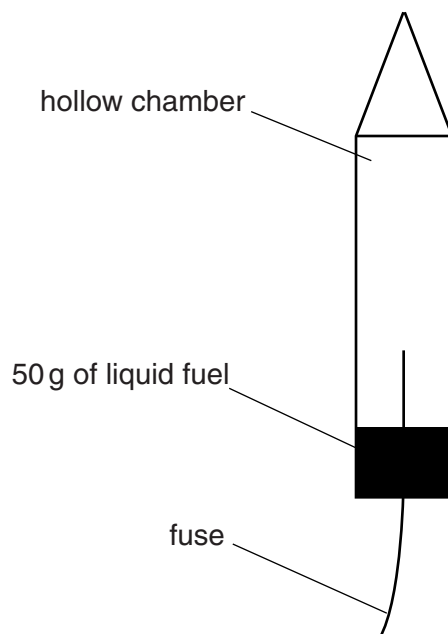

Denise lights the fuse of the rocket. The 50 g of fuel in the rocket ignites.

A very fast chemical reaction takes place which creates a large amount of hot gas.

The gas fills the hollow chamber.

- (a) The hot gas produces a high pressure inside the rocket.

Explain how the particles in the hot gas produce a high pressure in the rocket, making it move.

.....
.....
.....
..... [2]

- (b) Denise re-launches the same rocket.

This time, the rocket contains 100g of the same type of fuel.

The rocket lifts off and reaches a greater height than before.

Suggest why using more fuel produces a greater force and acceleration on the rocket.

.....
..... [1]

- (c) Rockets carry satellites into space.

These satellites can have different types of orbit around the Earth.

One type is a low polar orbit.

Another type is a geostationary orbit, which has an orbital period of 24 hours.

Describe and explain the differences in orbits, periods and speeds between geostationary orbits and low polar orbits.



The quality of written communication will be assessed in your answer to this question.

.....
.....
.....
.....
.....
.....
.....
.....
.....
.....
..... [6]

(d) A rocket was sent to Mars.

The rocket carried a vehicle called the Mars Rover.



The Mars Rover has a mass of 185 kg.

Its wheels are designed to carry a total weight of up to 1800 N.

The gravitational field strength (g) on Mars is 3.8 N/kg.

This means a mass of 1 kg on Mars weighs 3.8 N.

(i) Calculate the weight of the Rover vehicle on Mars.

.....

answer N [2]

(ii) Look at the table showing how gravitational field strength varies.

Place	Gravitational field strength in N/kg
Moon	1.6
Earth	10.0
Mars	3.8

Scientists are happy for the Rover to be used on the Moon or Mars.

They are very careful when using the Rover on Earth.

Use the data and information about the Rover to explain why.

.....

 [2]

[Total: 13]

7 (a) Quantities in science can be **vector** or **scalar**.

There are differences between vector and scalar quantities.

Look at the list.

mass momentum speed velocity weight

Put each quantity in the correct column in the table.

Vector	Scalar

[2]

(b) A skydiver drops vertically from a plane with a starting velocity of 0 m/s.

Calculate his speed after 7 s.

Assume his acceleration during this time is 8.0 m/s².

Put a **ring** around the correct answer.

15 m/s 28 m/s 30 m/s 56 m/s

[1]

(c) He now opens his parachute and decelerates steadily.

After 6 s his speed is 4 m/s.

Calculate the distance he falls during these 6 s.

.....

.....

.....

.....

answer m [2]

[Total: 5]

8 Many years ago, scientists tried to find out about light.

Some scientists, such as Newton, described light using a particle model.

Other scientists, such as Huygens, described light using a wave model.

Put ticks (✓) in the boxes to show which properties of light can be explained by each model.

Model	Property	
	Reflection	Interference
particle model		
wave model		

[2]

[Total: 2]

9 Helen does some research about the refractive index of different materials.

Material	Refractive index
glass (acrylic)	1.491
glass (arsenic trisulphide)	2.040
glass (common)	1.520
glass (71% lead)	1.805
water	1.333
air	1.000

The speed of light in a vacuum is 3.0×10^8 m/s.

Light travels at different speeds through different materials.

(a) Calculate the speed of light in water.

.....

.....

.....

answer m/s [2]

(b) Which material in the table will have the lowest critical angle when light passes from the material to air?

..... [1]

(c) Look at the diagram. It shows the dispersion of white light by a prism made from acrylic glass.

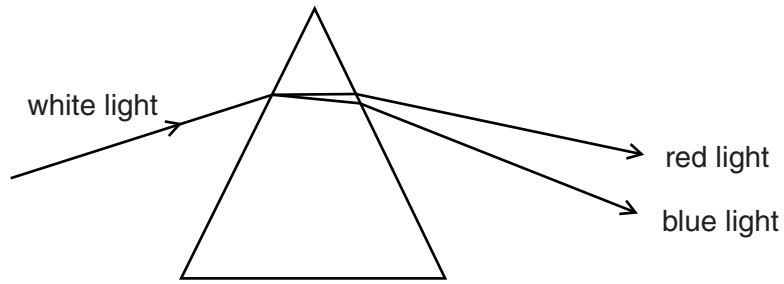

Use the diagram to explain why blue light has a higher refractive index than red light in this glass.

.....

.....

.....

..... [2]

[Total: 5]

SECTION C – Module P6

10 (a) Trevor and Una connect different circuits.

Look at the circuit Trevor connects.

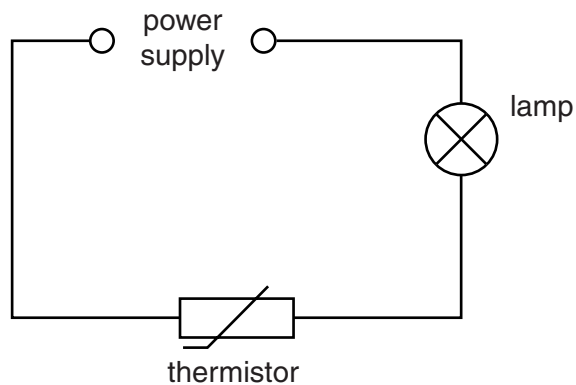

He gently heats the thermistor.

Describe and explain how heating the thermistor affects the brightness of the lamp.

.....

.....

..... [2]

(b) Look at the circuit Una connects.

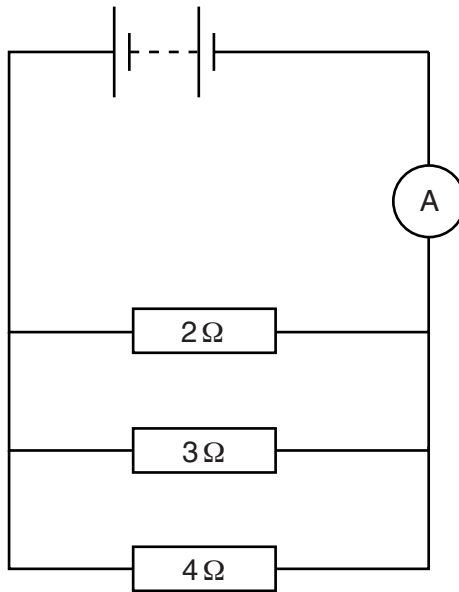

(i) Calculate the **total** resistance for this arrangement of resistors.

.....

.....

.....

.....

answer Ω [2]

(ii) The battery voltage is 4V.
Calculate the current supplied by the battery.

.....

.....

answer A [2]

(c) Look at the diagram of an NPN transistor.

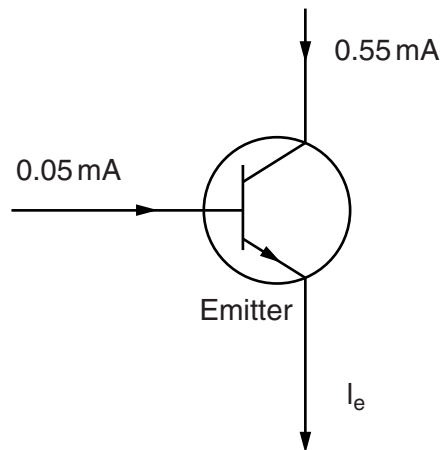

Calculate the current flowing from the emitter, I_e .

.....
.....

answer mA [1]

[Total: 7]

11 (a) Vic has a sealed box containing an electronic component.

The box has lost its label.

He connects a circuit containing the component in the box.

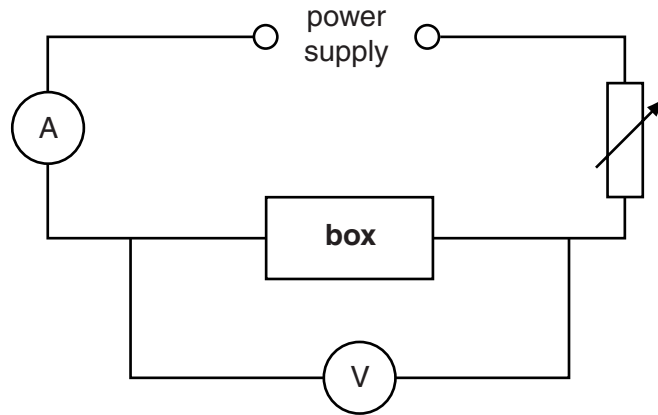

He changes the voltage across the box and measures the current.

Look at the graph of his measurements.

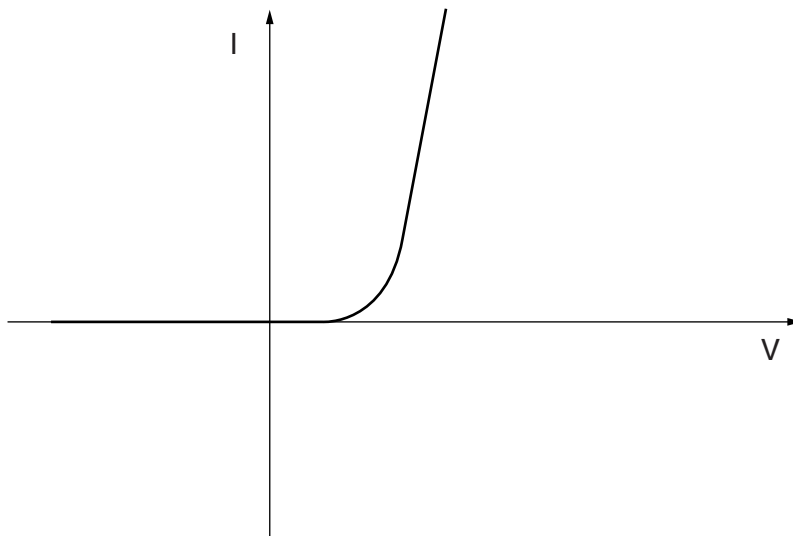

Write down the name of the component in the box.

.....

Explain your answer, using ideas about resistance.

.....

 [2]

(b) Look at the logic circuit.

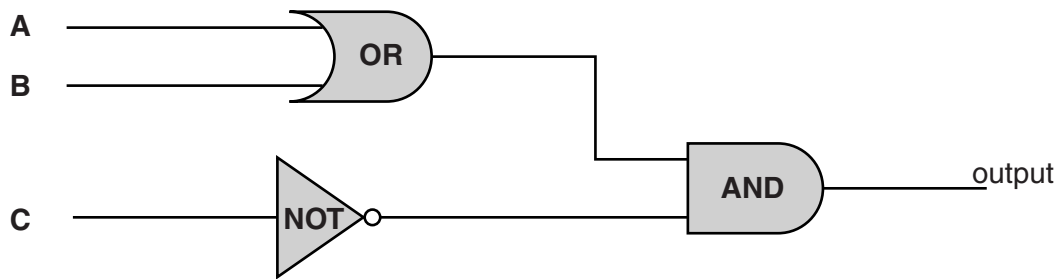

(i) Complete the truth table for the logic circuit.

A	B	C	Output
0	0	0	0
1	0	0	1
0	1	0	1
1	1	0	1
0	0	1	
1	0	1	
0	1	1	
1	1	1	

[1]

(ii) The circuit is used by a gardener in his greenhouse to control a fan.

A is a temperature sensor hot = 1

B is a moisture sensor wet = 1

C is a light sensor light = 1

What conditions are necessary for the fan to operate?

.....

.....

.....

..... [2]

(iii) The fan operates from the mains.

A relay must be connected between the output of the logic gate and the fan circuit.

Explain why.

.....

.....

.....

..... [2]

[Total: 7]

Question 12 begins on page 26

13 Computers will only work with a DC supply.

A bridge rectifier changes AC to DC.

Look at the diagram.

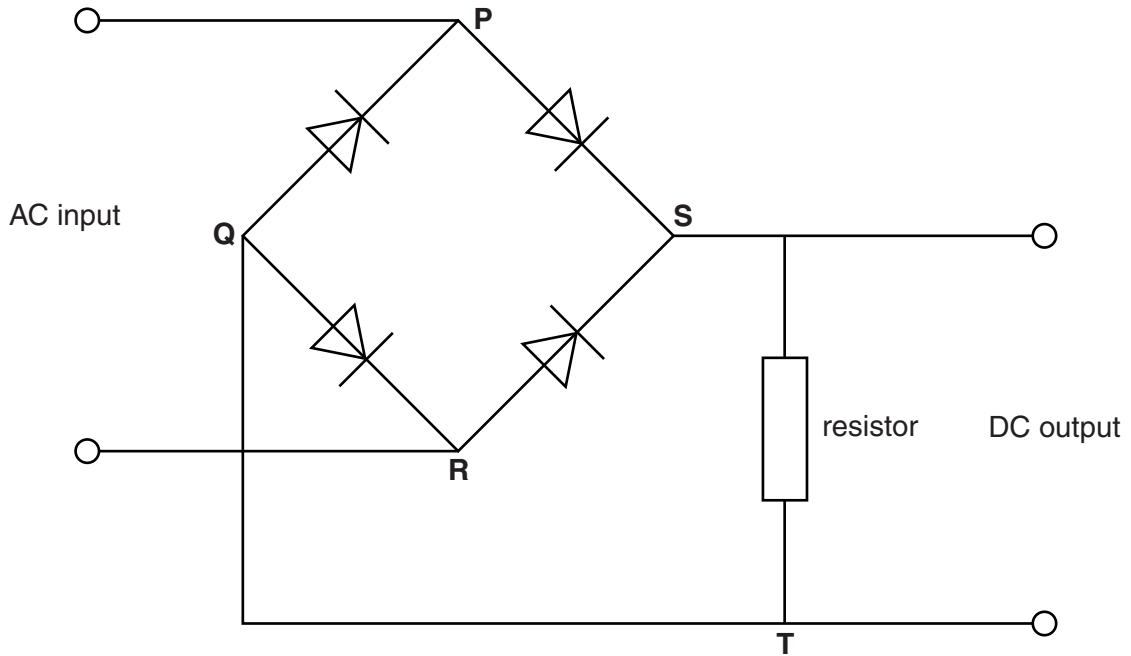

(a) Complete the following sentences to explain how this circuit changes AC to DC.

When the AC input makes **P** positive and **R** negative, the current

.....

When the AC input makes **P** negative and **R** positive, the current

.....

[2]

(b) A large capacitor is connected in parallel with the resistor.

Describe what effect this has on the DC output.

You may draw a diagram if you wish.

.....
.....
..... [1]

[Total: 3]

- 14 A microchip manufacturer has been asked to make electronic components for a new communications satellite.

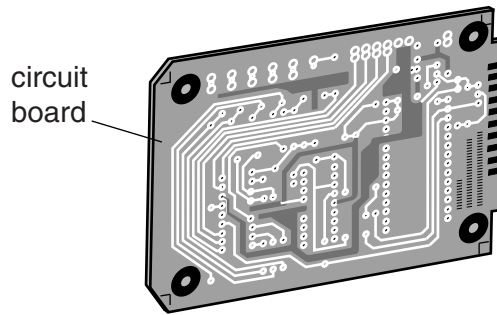

The manufacturer must make these components as small and as light as possible.

Write about the difficulties for the manufacturer in making very small components for the satellite.

.....

.....

.....

..... [2]

[Total: 2]

SECTION D

15 Car tyres grip the road when braking.

Tyres have a tread that wears away slowly with use.

New tyres have a tread that is 9 mm deep. The tread helps to move water away from the tyre when the road is wet.

This increases friction forces and improves braking.

(a) Look at the graph. It shows braking distances for tyres of different tread depths.

The data is for two different road surfaces on a wet day.

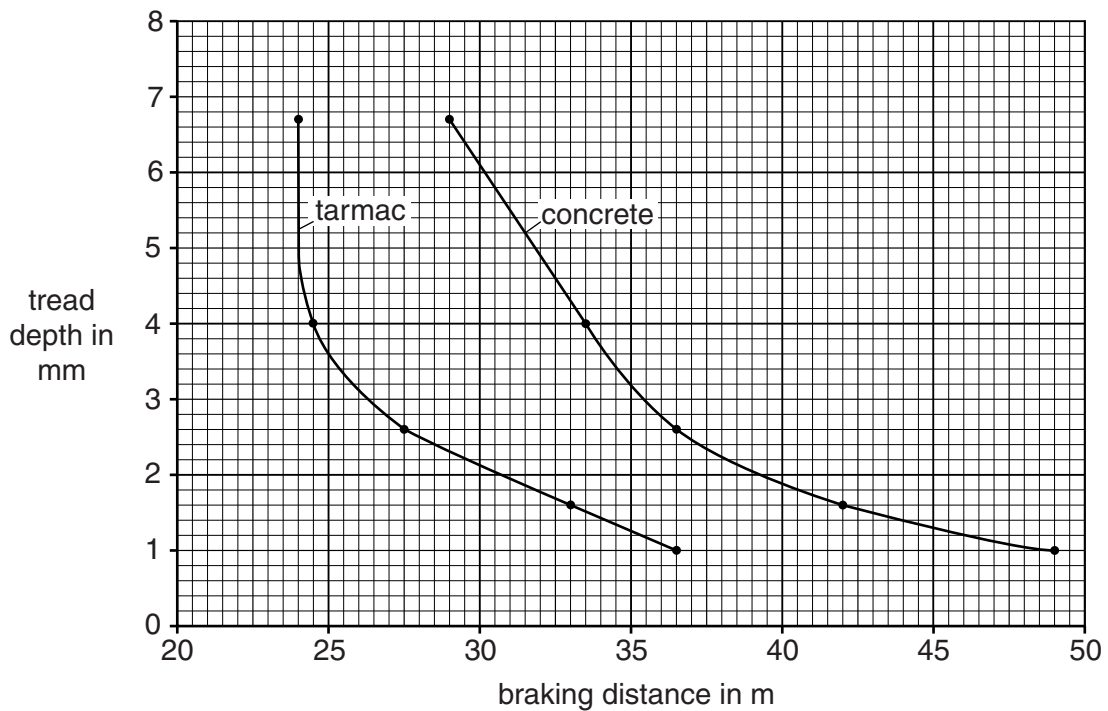

(i) Road safety experts recommend changing tyres when the tread depth reduces to 3 mm. Why is this more important for concrete surfaces rather than for tarmac surfaces?

.....

..... [1]

(ii) The data in the graph was collected using sets of tyres with different tread depths.

The driver fits each set of tyres to the same car.

Suggest other things the driver needs to do to ensure the results can be compared in a fair way.

.....
.....
..... [2]

(iii) The braking distance increases as the tread depth decreases.

Manjit calculates the percentage increase in braking distance for the tarmac.

She finds that reducing the tread depth from 6.7mm to 1.6mm changes the braking distance from 24m to 33m.

This is a 38% increase in braking distance.

Steve thinks that on concrete, for the same reduction in tread depth, the percentage increase in braking distance will double.

Is Steve correct?

Use a calculation to explain your answer.

.....
.....
.....
.....
.....
.....
..... [3]

(b) The minimum legal tread depth is 1.6 mm in the UK.

Manjit has some tyres that have a tread depth of 6.7 mm.

The garage tells her that, for normal driving, the tread should wear by 0.17 mm per 1000 km.

(i) Calculate how many kilometres she can expect to travel before the tyres are illegal.

.....
.....
.....

answer km [3]

(ii) It is unwise for Manjit to use the tyres for the distance calculated before replacing them.
Use the graph to explain why.

.....
..... [1]

[Total: 10]

END OF QUESTION PAPER



Copyright Information

OCR is committed to seeking permission to reproduce all third-party content that it uses in its assessment materials. OCR has attempted to identify and contact all copyright holders whose work is used in this paper. To avoid the issue of disclosure of answer-related information to candidates, all copyright acknowledgements are reproduced in the OCR Copyright Acknowledgements Booklet. This is produced for each series of examinations and is freely available to download from our public website (www.ocr.org.uk) after the live examination series.

If OCR has unwittingly failed to correctly acknowledge or clear any third-party content in this assessment material, OCR will be happy to correct its mistake at the earliest possible opportunity.

For queries or further information please contact the Copyright Team, First Floor, 9 Hills Road, Cambridge CB2 1GE.

OCR is part of the Cambridge Assessment Group; Cambridge Assessment is the brand name of University of Cambridge Local Examinations Syndicate (UCLES), which is itself a department of the University of Cambridge.