

Friday 7 June 2019 – Afternoon

GCSE (9–1) Biology B (Twenty First Century Science)

J257/04 Depth in Biology (Higher Tier)

Time allowed: 1 hour 45 minutes

You must have:

- a ruler (cm/mm)

You may use:

- a scientific or graphical calculator
- an HB pencil



Please write clearly in black ink. **Do not write in the barcodes.**

Centre number

--	--	--	--	--

Candidate number

--	--	--	--

First name(s)

Last name

INSTRUCTIONS

- Use black ink. You may use an HB pencil for graphs and diagrams.
- Answer **all** the questions.
- Where appropriate, your answers should be supported with working. Marks may be given for a correct method even if the answer is incorrect.
- Write your answer to each question in the space provided. If additional space is required, use the lined page(s) at the end of this booklet. The question number(s) must be clearly shown.

INFORMATION

- The total mark for this paper is **90**.
- The marks for each question are shown in brackets [].
- Quality of extended responses will be assessed in questions marked with an asterisk (*).
- This document consists of **28** pages.

Answer **all** the questions.

1 Photosynthesis takes place in plants.

(a) Put **one** tick in each row of the table to show the function of each plant structure.

Plant structure	Function		
	Transports sugars made by photosynthesis.	Carries out the reactions of photosynthesis.	Transports water needed for photosynthesis.
Chloroplast			
Phloem			
Xylem			

[1]

Eve is investigating the effect of temperature on photosynthesis in pondweed.

This is her method.

1. Put a piece of pondweed in a boiling tube.
2. Cover the pondweed with sodium hydrogen carbonate solution (a source of carbon dioxide).
3. Put the boiling tube in a beaker of water at one of six temperatures.
4. Use a gas syringe to collect the bubbles of gas released from the pondweed.
5. Record the volume of gas collected in five minutes.
6. She repeats the experiment three times at each temperature.

Fig. 1.1 shows the apparatus Eve uses.

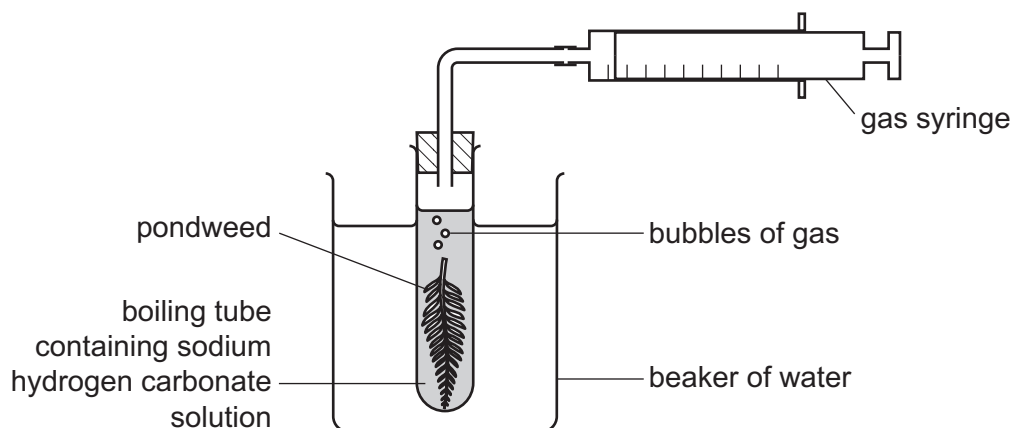

Fig. 1.1

(b) Temperature is the variable that Eve will change.

Write down **one** variable that Eve should control **and** describe how she could control it.

.....

.....

.....

..... [2]

(c) After she has finished the investigation, Eve uses her data to plot the graph in **Fig. 1.2**.

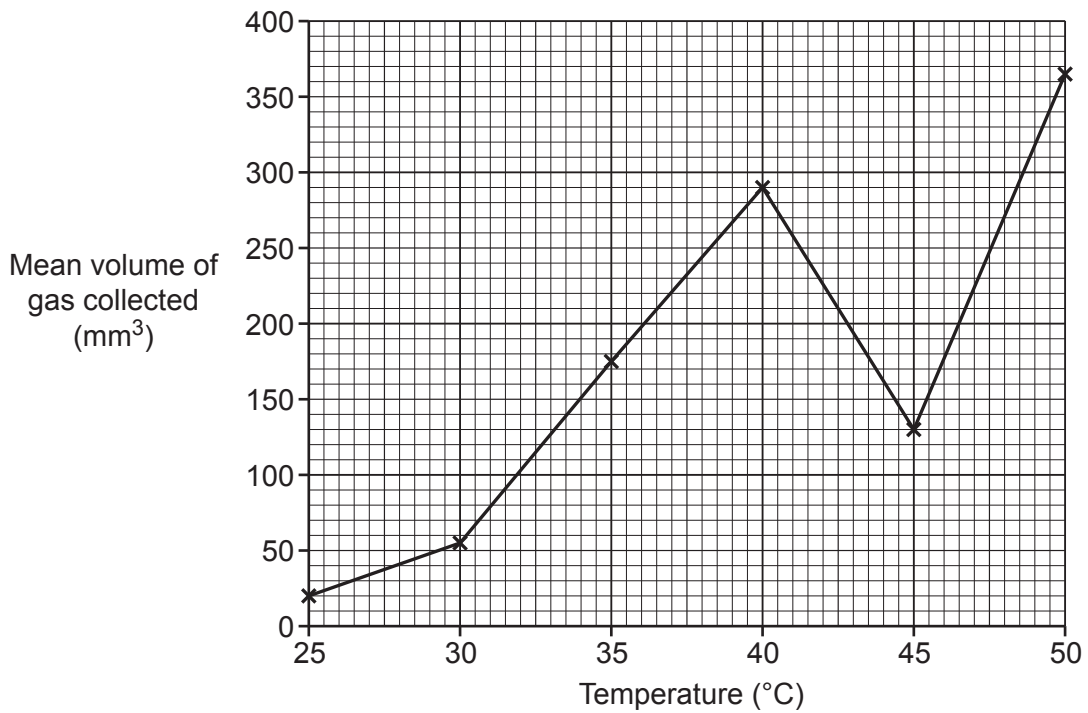

Fig. 1.2

(i) Eve decides to repeat the experiment at 45 °C so that she can take new measurements at this temperature.

Use evidence from **Fig. 1.2** to justify Eve's decision.

.....

.....

.....

..... [2]

(ii) Here are Eve's new measurements.

Temperature (°C)	Volume of gas collected (mm ³)		
	Repeat 1	Repeat 2	Repeat 3
45	354	360	351

Use Eve's new measurements to complete the graph in **Fig. 1.3**.

You may use the space below for working out.

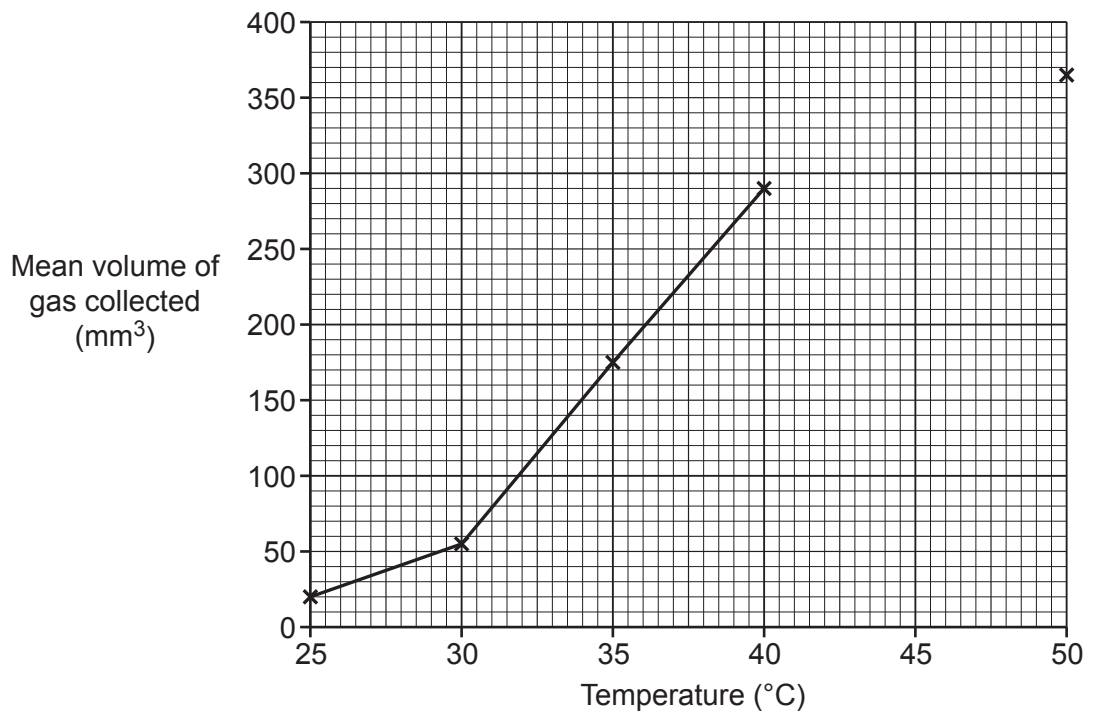

Fig. 1.3

[2]

7
BLANK PAGE

PLEASE DO NOT WRITE ON THIS PAGE

3 Plastic pollution in the sea is a big problem.

Look at the food web from the North Sea.

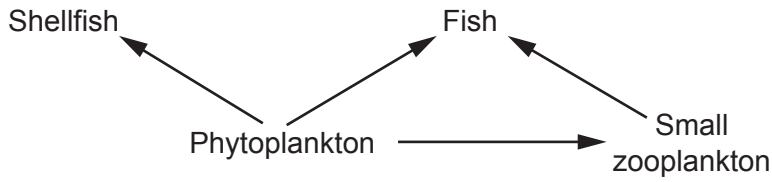

(a) What does the word “Fish” represent in the food web?

Tick (✓) **one** box.

An individual organism

A population

A producer

A species

[1]

(b) Explain the difference between a community and an ecosystem using examples from the food web.

.....

.....

.....

..... [2]

Plastic litter in the sea breaks down slowly into small pieces called microplastics.

The table gives information about phytoplankton, microplastics and small zooplankton.

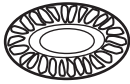
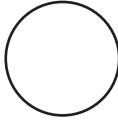
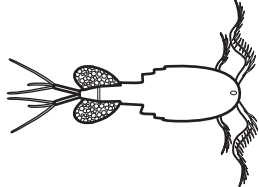
	Phytoplankton	Microplastics	Small zooplankton
			
Size	Up to 0.2 mm	Up to 5 mm	Up to 20 mm
Can be digested by fish?	Yes	No	Yes

Fish can eat anything that is less than or equal to 20 mm in size.

(c) Explain why plastic litter in the sea could cause a decrease in the numbers of fish.

.....
.....
.....
.....
.....
..... [3]

(d) Scientists have discovered some bacteria in a rubbish dump. These bacteria can break down plastic litter very quickly.

(i) Some people think we should put the bacteria in the North Sea to break down plastic litter.

Suggest and explain how this could put the North Sea ecosystem at even greater risk.

.....
.....
.....
.....
.....
.....
.....
..... [4]

(ii) Bacteria gaining the ability to break down plastic is an example of evolution.

Explain what changes must have taken place in **the bacteria cells** to give them the ability to break down plastic.

.....
.....
.....
..... [2]

10
BLANK PAGE

PLEASE DO NOT WRITE ON THIS PAGE

4 Ling and Kai are investigating the stomata of plant leaves.

(a) Ling wants to work out the size of one stoma (one of the stomata of a leaf).

She uses a light microscope to look at the underside of a leaf.

She uses a camera attached to the microscope to take a photograph.

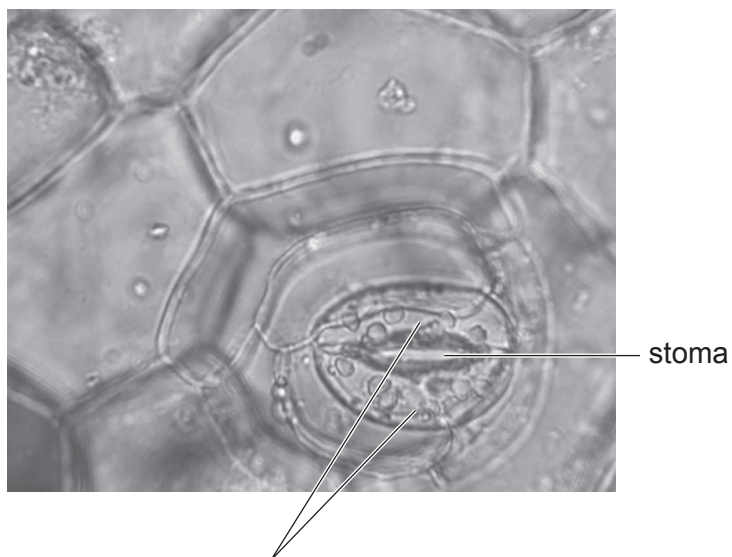

(i) Complete the labelling of the photograph.

[1]

(ii) The length of the stoma in Ling's photograph is 15 mm.

The photograph has a magnification of $\times 400$.

Calculate the length of the original stoma.

Give your answer in standard form.

Length = mm [2]

(b) Kai wants to work out how many stomata are found in each mm^2 of the leaf's surface.

- He paints clear nail varnish onto a small area of the underside of a leaf.
- When the varnish has dried he peels it off using clear sticky tape.
- He sticks the tape onto a microscope slide.

Kai will use a light microscope to count the impressions of stomata in the varnish.

Here is his planned method.

1. Clip the slide on the stage.
2. Rotate the objective lens until it clicks into position above the slide.
3. Place the microscope in direct sunlight and look into the eyepiece lens. Adjust the mirror until the image is as bright as possible.
4. Look into the eyepiece lens and use the coarse focus to move the objective lens towards the slide until the image is in focus.
5. Use the fine focus to move the objective lens away from the slide until the image is as sharp as possible.

Fig. 4.1 shows the light microscope Kai uses.

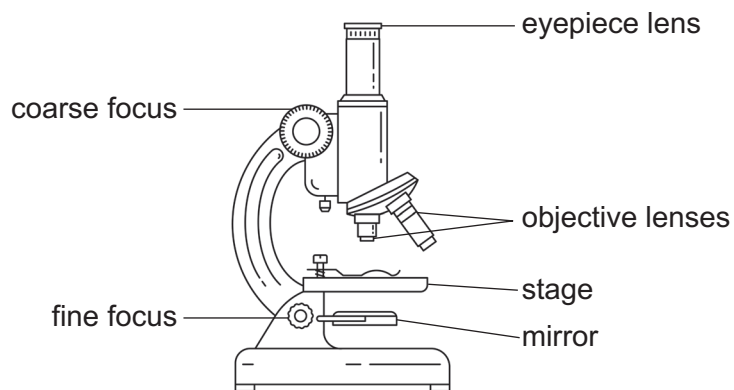

Fig. 4.1

- (i) Write down the numbers of **two** steps in Kai's method that have a high risk of causing damage to Kai or the apparatus.

For each of these steps, explain why it is dangerous **and** suggest how to reduce the risk.

step

why it is dangerous

.....

how to reduce the risk

.....

step

why it is dangerous

.....

how to reduce the risk

..... **[4]**

- (ii) Kai sets up the microscope using a safer method provided by his teacher.

He puts a clear plastic ruler on the stage.

He uses the microscope to look at the millimetre markings on the ruler. **Fig. 4.2** shows what he sees.

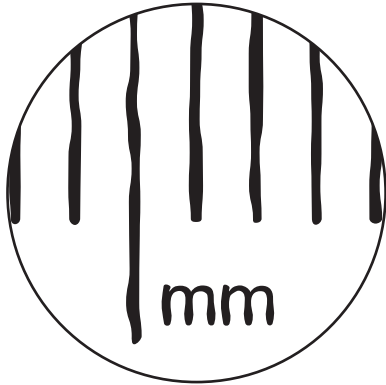

Fig. 4.2

In **Fig. 4.2** the distance between each marking is 1 mm.

Calculate the area of the field of view.

In your calculation, assume $\pi = 3.14$.

Give your answer to **3** significant figures.

Area = mm² [3]

(iii) Kai removes the ruler from the stage and replaces it with the slide showing stomata.

He makes no other changes to the microscope. **Fig. 4.3** shows what he sees.

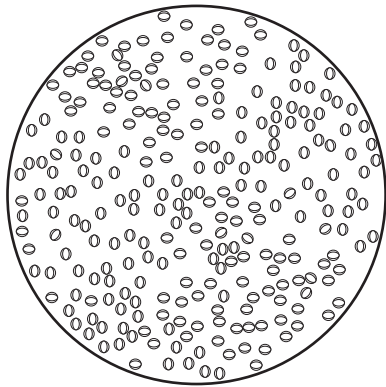

Fig. 4.3

Kai counts 255 stomata in the field of view.

Estimate the density of stomata (how many are found in each mm²) in this field of view.

Density = stomata per mm² [1]

(iv) Suggest why the density of stomata in this field of view may **not** be the same as the density of stomata over the whole leaf surface.

.....

.....

.....

.....

..... [2]

5 Smoking cigarettes is linked to lung cancer.

(a) The National Health Service (NHS) in England helped 196 000 people who wanted to stop smoking in 2017.

(i) After using the NHS, 98 000 of these people told their doctor they had stopped smoking.

What percentage of the people who used the NHS said they had stopped smoking?

Percentage of people = % [1]

(ii) Doctors tested the breath of all the people who said they had stopped smoking.

The tests showed that 72% of these people really had stopped smoking.

How many people had successfully stopped smoking?

Number of people = people [1]

(b) Cigarette smoke contains carcinogens.

Carcinogens are substances that can cause mutations in a cell's DNA.

Explain how this can lead to cancer.

.....

.....

.....

.....

.....

.....

..... [3]

(c) Some people who want to stop smoking cigarettes start using e-cigarettes (vaping) instead.

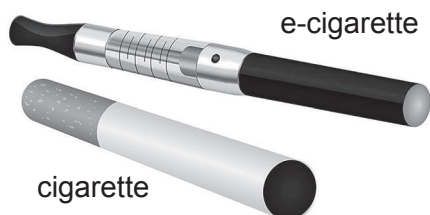

Cigarette smoke and e-cigarette vapour both contain carcinogens called NNK, benzene and acrolein.

Scientists measured the concentrations of these carcinogens in the saliva and urine of three groups of people. The groups had behaved in different ways for six months.

The results are shown in the bar chart.

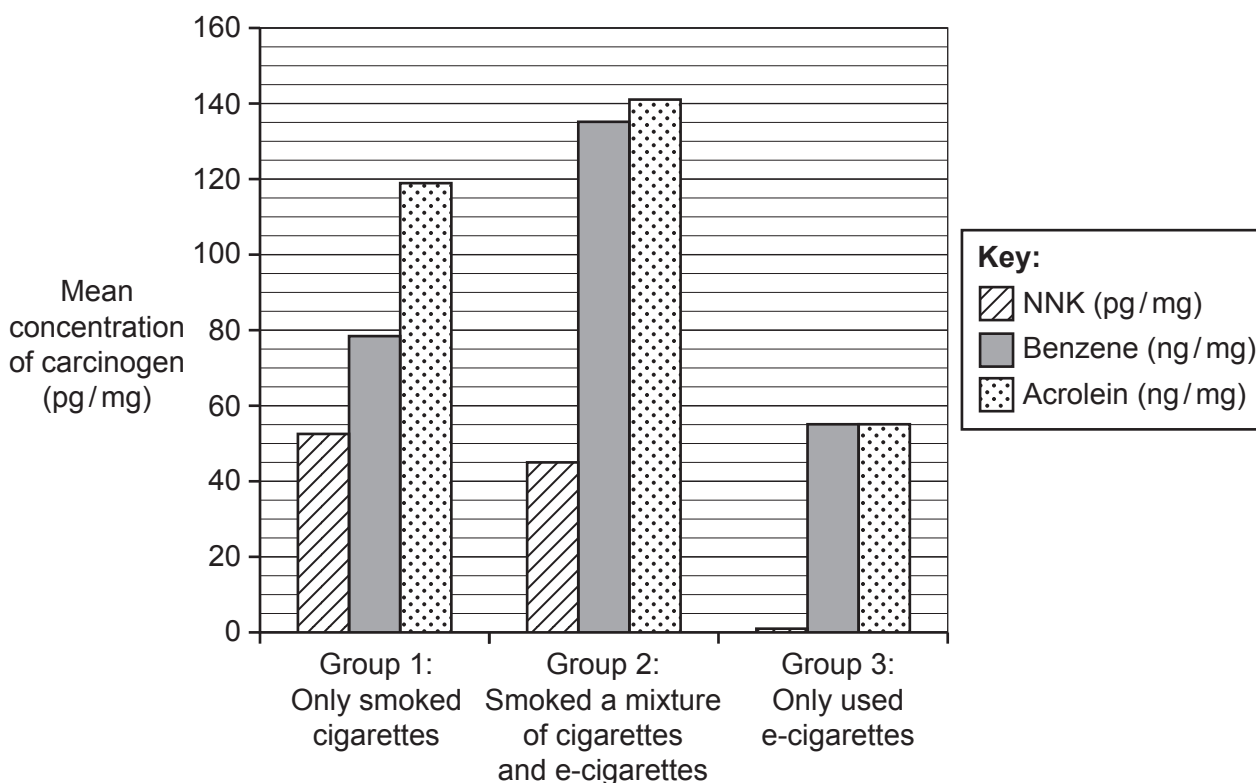

(i) The mean concentration of NNK for Group 1 was 53 pg/mg
The mean concentration of NNK for Group 3 was 1 pg/mg.

Calculate the percentage change in the mean concentration of NNK in Group 3 compared to Group 1.

Percentage change = % [2]

(ii) Read the news headline:

E-cigarettes 98% safer than cigarettes

Do you agree with the headline? Explain your answer.

.....
.....
.....
..... [2]

(iii)* Beth is worried because her mother and sister both died from lung cancer.

She plans to reduce the number of cigarettes she smokes and she will use an e-cigarette the rest of the time.

Describe the factors that affect Beth’s risk of developing lung cancer **and** explain the best course of action for her.

.....
.....
.....
.....
.....
.....
.....
.....
.....
.....
.....
.....
.....
.....
.....
.....
.....
..... [6]

6 Red blood cells carry oxygen.

(a) Red blood cells are made from adult stem cells in the bone marrow.

(i) A stem cell divides by mitosis to make red blood cells.

Mitosis is one stage of the cell cycle. The other stage is interphase.

Complete the table to describe three things that happen during each stage of the cell cycle.

Interphase	Mitosis
1 The cell grows larger	1
2	2 The nucleus divides
3	3 The cell divides

[3]

(ii) Explain how a stem cell is able to become a different type of cell.

.....
.....
.....
.....
.....
.....
..... [3]

23
BLANK PAGE

PLEASE DO NOT WRITE ON THIS PAGE

7 Enzymes catalyse reactions in living organisms.

(a) The graph shows how the activity of a human enzyme changes as the temperature changes.

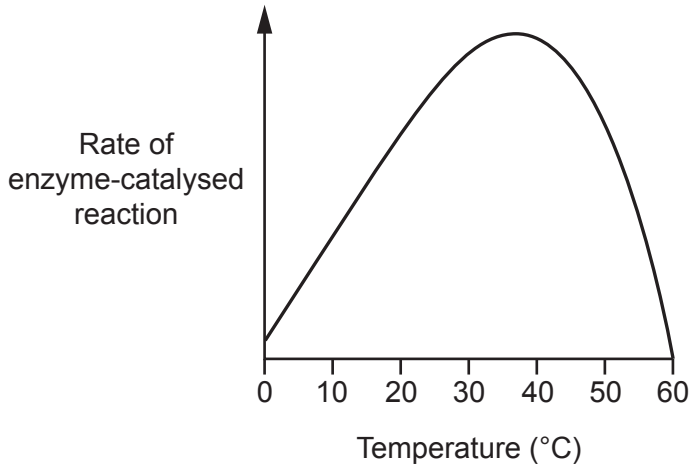

(i) Use the graph to explain why it is important for the human body to maintain a constant internal temperature of 37 °C.

.....

.....

.....

.....

.....

.....

.....

..... [3]

(ii) Scientists have found single-celled organisms called thermophiles living around hot vents on the sea floor.

Thermophiles cannot control their temperature. The cell and its contents are the same temperature as the seawater.

The temperature of the seawater around one hot vent is 50 °C.

Suggest **and** explain how you would expect the graph to look for an enzyme from a thermophile living around this vent.

.....

.....

.....

..... [2]

(iii) The seawater around the vent has a very high concentration of salt.

Describe **and** explain how this could affect the single-celled thermophiles.

.....

.....

.....

.....

.....

.....

..... [3]

(b) Scientists have been studying two different enzymes in invertebrates.

- Both enzymes break down the same substrate.
- The shape of the active site of each enzyme is the same.
- Each enzyme is coded for by a different gene.
- There are some differences in the sequences of bases in the two genes because of mutations.

Explain how the two enzymes could have the same shaped active site when they are made from genes with differences in their base sequences.

.....

.....

.....

.....

.....

.....

.....

.....

..... [4]

END OF QUESTION PAPER

ADDITIONAL ANSWER SPACE

If additional space is required, you should use the following lined page(s). The question number(s) must be clearly shown in the margin(s).

A large area of lined paper for writing. It features a vertical solid line on the left side, creating a margin. The rest of the page is filled with horizontal dotted lines, providing space for writing answers.

A large rectangular area with a solid vertical line on the left side and horizontal dotted lines extending across the page, providing a space for writing answers.



Copyright Information

OCR is committed to seeking permission to reproduce all third-party content that it uses in its assessment materials. OCR has attempted to identify and contact all copyright holders whose work is used in this paper. To avoid the issue of disclosure of answer-related information to candidates, all copyright acknowledgements are reproduced in the OCR Copyright Acknowledgements Booklet. This is produced for each series of examinations and is freely available to download from our public website (www.ocr.org.uk) after the live examination series.

If OCR has unwittingly failed to correctly acknowledge or clear any third-party content in this assessment material, OCR will be happy to correct its mistake at the earliest possible opportunity.

For queries or further information please contact The OCR Copyright Team, The Triangle Building, Shaftesbury Road, Cambridge CB2 8EA.

OCR is part of the Cambridge Assessment Group; Cambridge Assessment is the brand name of University of Cambridge Local Examinations Syndicate (UCLES), which is itself a department of the University of Cambridge.