

Write your name here

Surname

Other names

Pearson
Edexcel GCE

Centre Number

--	--	--	--	--

Candidate Number

--	--	--	--

Physics

Advanced

Unit 4: Physics on the Move

Wednesday 11 June 2014 – Afternoon

Time: 1 hour 35 minutes

Paper Reference

6PH04/01R

You do not need any other materials.

Total Marks

Instructions

- Use **black** ink or ball-point pen.
- **Fill in the boxes** at the top of this page with your name, centre number and candidate number.
- Answer **all** questions.
- Answer the questions in the spaces provided
– *there may be more space than you need.*

Information

- The total mark for this paper is 80.
- The marks for **each** question are shown in brackets
– *use this as a guide as to how much time to spend on each question.*
- Questions labelled with an **asterisk** (*) are ones where the quality of your written communication will be assessed
– *you should take particular care with your spelling, punctuation and grammar, as well as the clarity of expression, on these questions.*
- The list of data, formulae and relationships is printed at the end of this booklet.
- Candidates may use a scientific calculator.

Advice

- Read each question carefully before you start to answer it.
- Keep an eye on the time.
- Try to answer every question.
- Check your answers if you have time at the end.

Turn over ►

P43271A

©2014 Pearson Education Ltd.

1/1/1/1



PEARSON

SECTION A

Answer ALL questions.

For questions 1–10, in Section A, select one answer from A to D and put a cross in the box . If you change your mind, put a line through the box and then mark your new answer with a cross .

- 1 A particle moving in a circular path completes 8.0 revolutions in 5.0 s.
Its angular velocity in rad s^{-1} is

- A 1.6
 B 10
 C 40
 D 250

(Total for Question 1 = 1 mark)

- 2 Electric field strength can have the unit of

- A V m
 B V C^{-1}
 C N m^{-1}
 D N C^{-1}

(Total for Question 2 = 1 mark)

- 3 When alpha particles are directed at a thin gold foil it is found that most of the alpha particles go straight through undeflected. However a very small number are scattered through angles greater than 90° .

Which of the following is **not** a valid conclusion?

- A The atom is mainly empty space.
 B The nucleus must be positively charged.
 C The nucleus must contain most of the mass of the atom.
 D There is a large charge concentration in the centre of the atom.

(Total for Question 3 = 1 mark)



- 4 A football is kicked horizontally to hit a wall. Its momentum just before it hits the wall is 9.0 kg m s^{-1} . It rebounds horizontally from the wall with a momentum of -6.0 kg m s^{-1} . The graph shows how the momentum of the football varies during the impact with the wall.

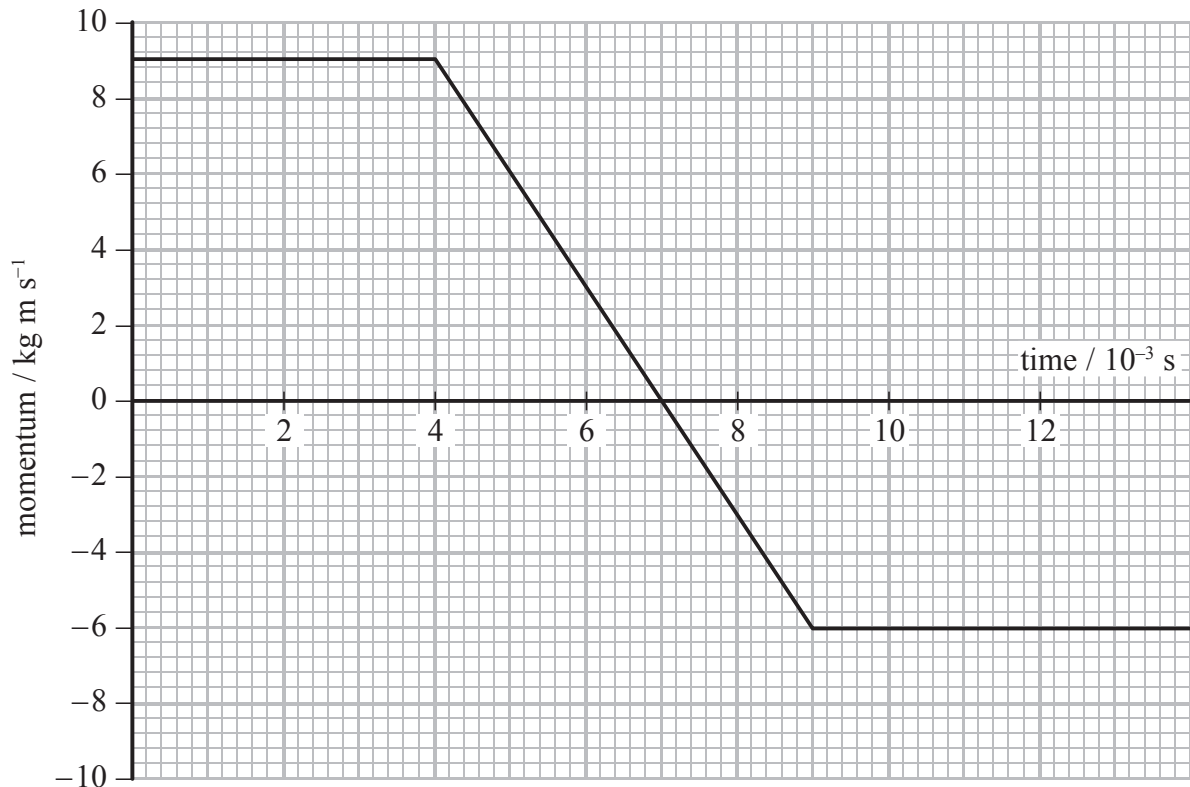

The force exerted by the wall on the football is

- A 3.0 N
- B 15 N
- C 600 N
- D 3000 N

(Total for Question 4 = 1 mark)

- 5 Which of the following statements is always true for an inelastic collision?

- A Both momentum and kinetic energy are conserved.
- B Neither momentum nor kinetic energy is conserved.
- C Kinetic energy is not conserved.
- D Momentum is not conserved.

(Total for Question 5 = 1 mark)



6 As a particle accelerates in a linear accelerator (linac), it passes through tubes that get progressively longer.

Which of the following statements is the correct reason for making the tubes longer?

- A The particles gain more energy within each tube.
- B The frequency of the accelerating voltage increases.
- C The accelerating particles spend the same time in each tube.
- D The accelerating particles gain mass.

(Total for Question 6 = 1 mark)

7 A capacitor of capacitance C has a potential difference V across it. The energy stored on the capacitor is Z joules. A second capacitor of capacitance $C/2$ has a potential difference $2V$ across it.

The energy stored on the second capacitor is

- A Z
- B $2Z$
- C $4Z$
- D $8Z$

(Total for Question 7 = 1 mark)

8 An electron gun uses a potential difference V to accelerate electrons of mass m and charge e from rest to a speed v .

The potential difference V can be expressed as

- A $\frac{mv^2}{2e}$
- B $\frac{2ev^2}{m}$
- C $\sqrt{\frac{2ev}{m}}$
- D $\sqrt{\frac{mv}{2e}}$

(Total for Question 8 = 1 mark)



9 Pions are the lightest mesons. A negative pion (π^-) has a mass of 2.48×10^{-28} kg.

Which of the following is the mass of the π^- in MeV/c²?

- A 1.4×10^8
- B 1.4×10^2
- C 4.7×10^{-7}
- D 3.6×10^{-24}

(Total for Question 9 = 1 mark)

10 The process by which electrons are released from a heated metal filament in an electron beam tube is called

- A excitation.
- B ionisation.
- C photoelectric emission.
- D thermionic emission.

(Total for Question 10 = 1 mark)

TOTAL FOR SECTION A = 10 MARKS



SECTION B

Answer ALL questions in the spaces provided.

11 The photograph shows a bridge.



The diagram shows a car of mass 950 kg at the highest point X of the bridge.

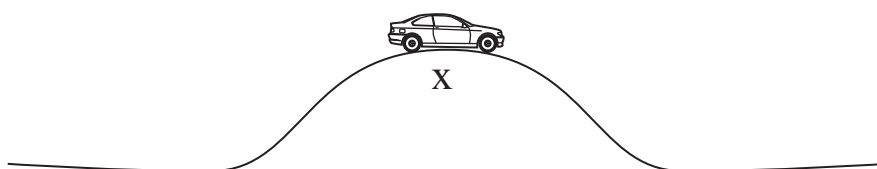

The bridge forms part of a vertical circle of radius 20.0 m.

(a) Calculate the total upward force R of the road on the car:

(i) when the car is stationary at X,

(1)

$R =$

(ii) when the car is passing point X at a speed of 12.0 m s^{-1} .

(3)

$R =$



(b) The car is repeatedly driven over the bridge at gradually increasing speeds. Above a certain speed the car loses contact with the road at X.
State why this happens.

(1)

.....

.....

.....

(Total for Question 11 = 5 marks)



*12 Particle accelerators accelerate particles to very high speeds before collisions occur.
New particles are created during the collisions.

Two particles of the same type can undergo two kinds of collision.

Fixed target: a high speed particle hits a stationary particle.

Colliding beams: two particles travelling at high speeds, in opposite directions, collide head-on.

By considering the conservation of energy and momentum, explain which type of collision is able to create a new particle with the largest mass.

(6)

.....

.....

.....

.....

.....

.....

.....

.....

.....

.....

.....

.....

.....

.....

.....

.....

.....

.....

.....

.....

.....

.....

(Total for Question 12 = 6 marks)



13 (a) State what is meant by the de Broglie wavelength.

(2)

.....

.....

.....

(b) An electron is accelerated from rest, in a vacuum, through a potential difference of 500 V.

(i) Show that the final momentum of the electron is about 1×10^{-23} N s.

(3)

.....

.....

.....

.....

.....

(ii) Calculate the de Broglie wavelength for this electron.

(2)

.....

.....

.....

de Broglie wavelength =

(Total for Question 13 = 7 marks)



14 A mass-spectrometer is an instrument that is used to measure the masses of molecules. Molecules of a gas are ionised and travel through a vacuum in a narrow tube. The ions enter a region of uniform magnetic flux density B where they are deflected in a semicircular path as shown.

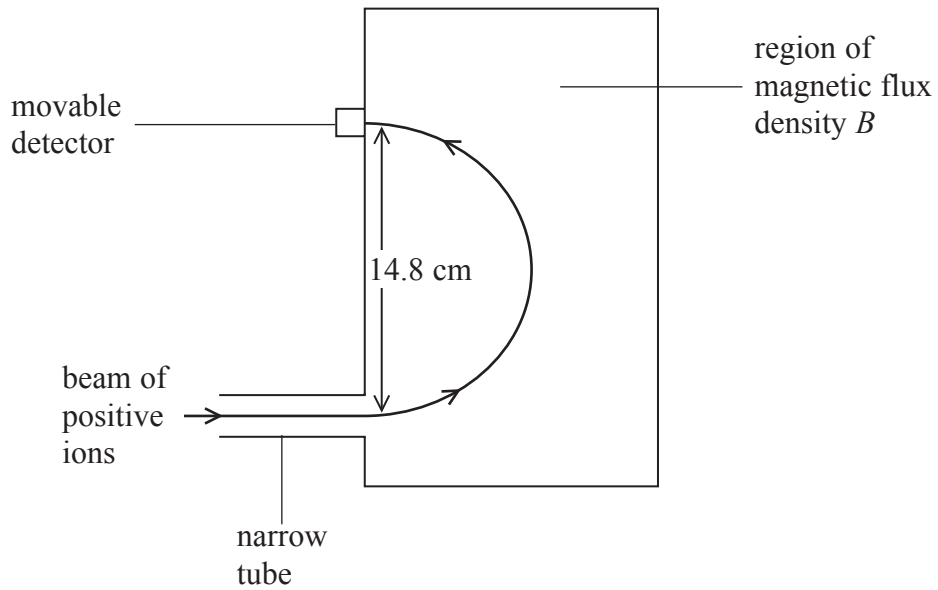

(a) State why it is necessary for the molecules to be ionised. (1)

.....

.....

(b) State the direction of the magnetic field. (1)

.....

.....

.....



(c) The ions have a charge of $+e$ and a speed of $1.20 \times 10^5 \text{ m s}^{-1}$. When B has a value of 0.673 T , the ions are detected at a point where the diameter of the arc is 14.8 cm .

Calculate the mass of an ion.

(3)

.....

.....

.....

.....

.....

.....

Mass of an ion =

(d) Ions with a smaller mass but the same charge and speed are also present in the beam.
On the diagram sketch the path of these ions.

(1)

(Total for Question 14 = 6 marks)



- 15 A student is investigating electromagnetic induction using a U-shaped magnet. The magnetic flux density between the poles of the magnet is 74 mT. The magnetic field outside the region of the poles is negligible. She places a stiff copper wire between the poles of the magnet as shown in the diagram. The wire is connected to an ammeter of resistance 0.25Ω .

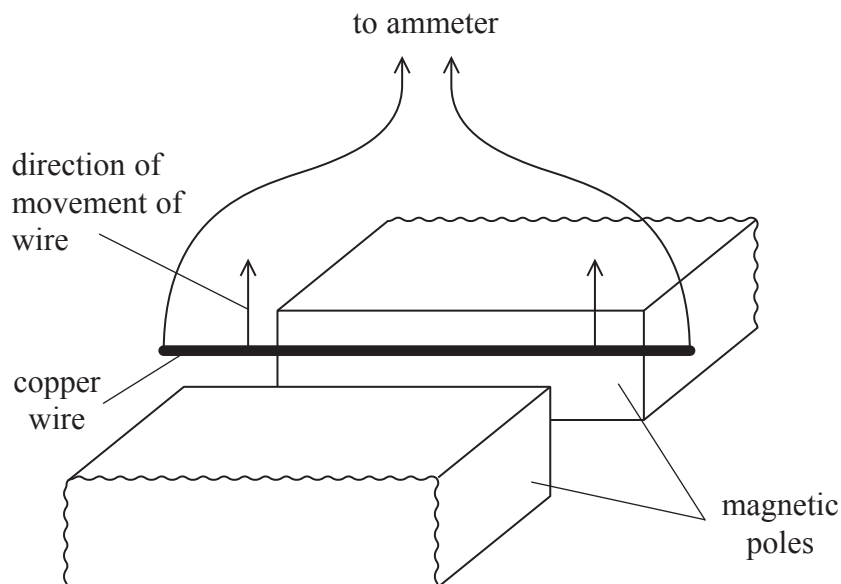

- (a) The rectangular poles measure $6.0 \text{ cm} \times 2.4 \text{ cm}$.

Show that the magnetic flux between the poles of the magnet is about $1 \times 10^{-4} \text{ Wb}$.

(3)

.....

.....

.....

.....

.....

.....



(b) The student holds the wire as shown in the diagram and moves it vertically upwards at a constant speed of 1.2 m s^{-1} .

Calculate the e.m.f. induced in the wire when it is moving.

(3)

.....

.....

.....

.....

.....

.....

Induced e.m.f. =

(c) According to Lenz's law, a force will act on the wire to oppose the motion of the wire.

Calculate the magnitude of the force that opposes the motion and comment on this value.

(4)

.....

.....

.....

.....

.....

Magnitude of force =

Comment

.....

.....

(Total for Question 15 = 10 marks)



BLANK PAGE



16 A student carries out an experiment to investigate the force acting between two charged objects. A lightweight negatively-charged ball is freely suspended from the ceiling by an insulating thread. The ball is repelled by a negatively-charged sphere that is placed near it on an insulated support.

The angle of deflection is θ and r is the distance between the centres of the ball and the sphere.

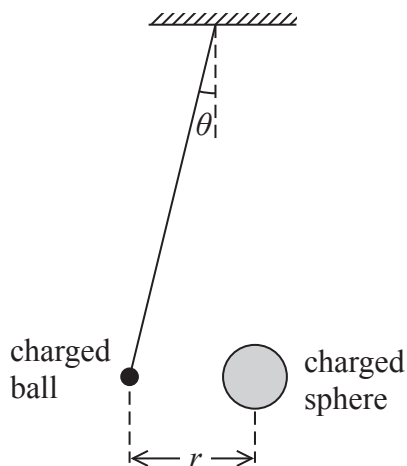

(a) (i) Draw a free-body force diagram for the suspended ball.

(2)



(ii) The weight of the suspended ball is W .

Show that the force of repulsion F on the suspended ball is given by

$$F = W \tan \theta$$

(2)

.....

.....

.....

.....

.....



- (b) (i) The student can increase the magnitude of the force by moving the sphere towards the suspended ball. She takes pairs of measurements of r and θ and calculates the magnitude of the force F . She then plots a graph of F against r .

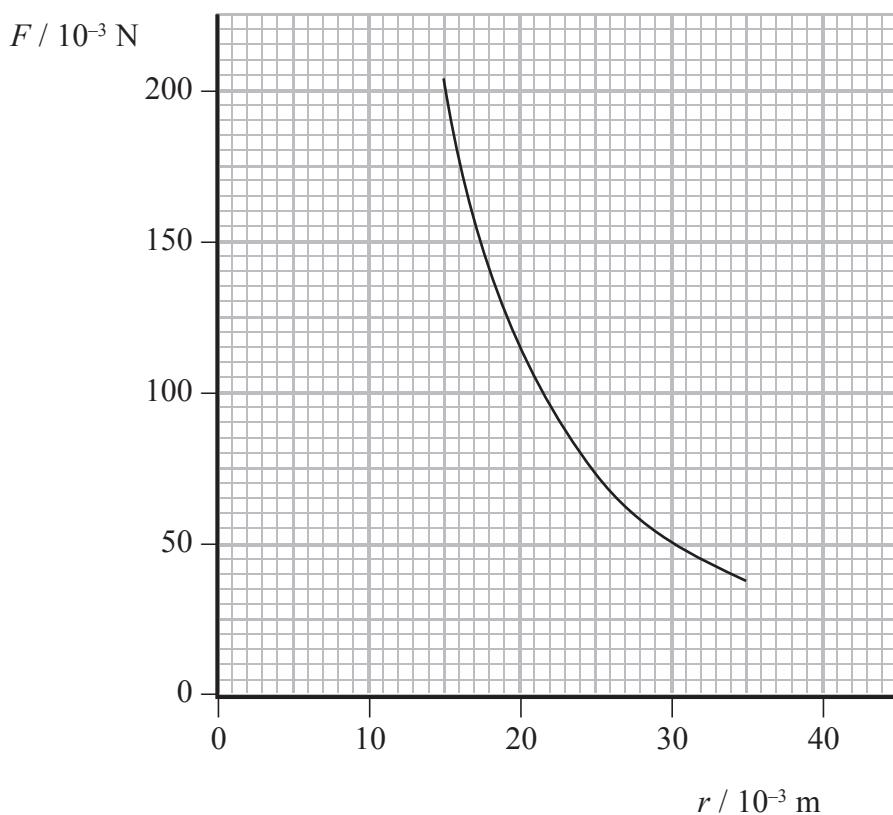

Use readings from the graph to demonstrate that the relationship between F and r obeys an inverse square law.

(4)

.....

.....

.....

.....

.....

.....

.....

.....

.....

.....

.....



(ii) The charge on the sphere is 100 times greater than the charge on the ball.

Calculate the charge on the ball.

(3)

Charge =

(Total for Question 16 = 11 marks)



17 The graph shows how the output V from the terminals of a power supply labelled d.c. (direct current) varies with time t . This type of supply will not allow current to flow backwards through it.

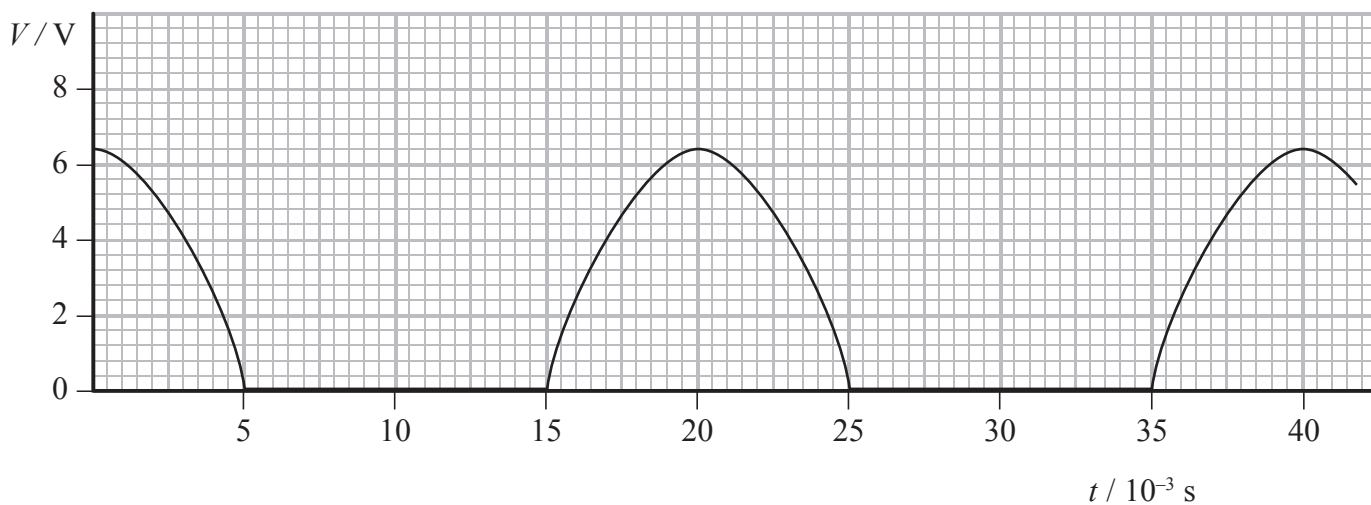

(a) A student connects a capacitor across the terminals of this power supply in order to try to produce a constant voltage.

Suggest how this produces a constant voltage.

(2)

.....

.....

.....

.....

(b) The student then connects a resistor across the capacitor as shown.

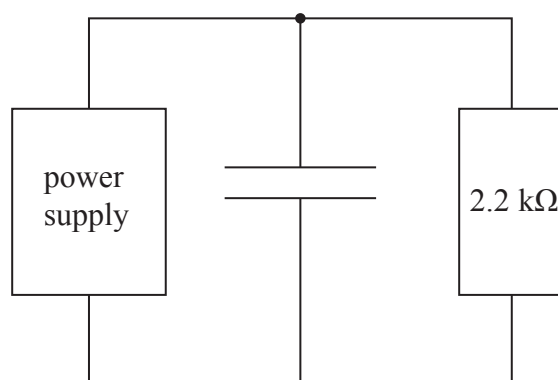

The graph shows the variation of the potential difference V across the resistor with time t .

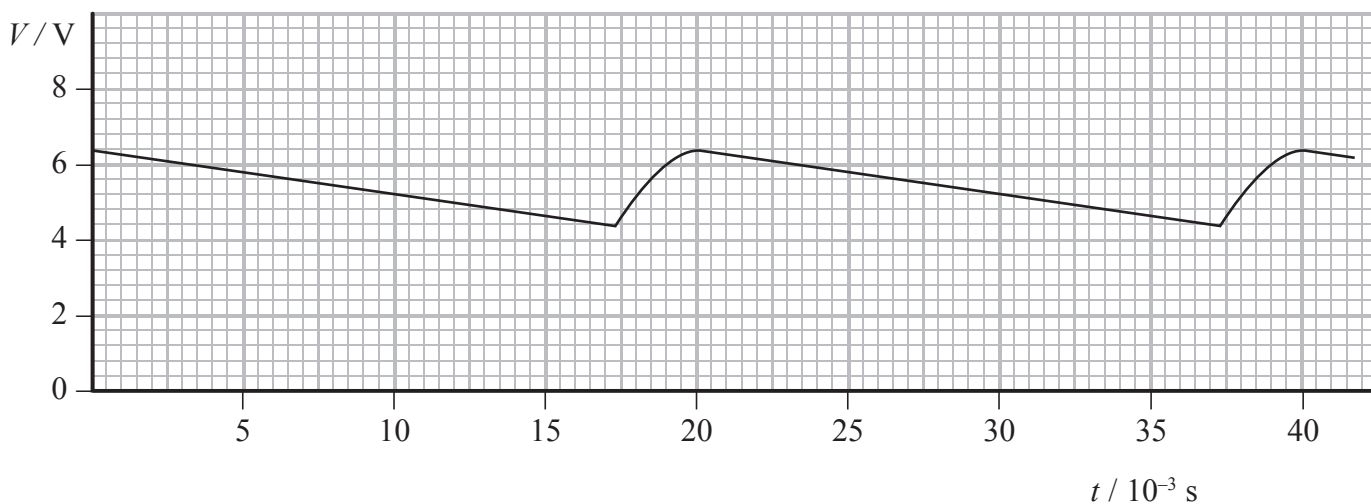

(i) Estimate the average potential difference across the resistor.

(1)

Average potential difference =

(ii) Calculate the average current in the resistor.

(2)

Average current =

(iii) Determine the time in each cycle for which the capacitor discharges through the resistor.

(1)

Discharge time =



(iv) Calculate the charge passing through the resistor during one discharge of the capacitor and hence determine the capacitance of the capacitor.

(4)

.....

.....

.....

.....

.....

.....

.....

.....

.....

.....

.....

Charge =

Capacitance =

(c) The student wants to produce a potential difference across the same resistor that has less variation in magnitude.

State, with a reason, what the student could do to achieve this.

(2)

.....

.....

.....

.....

(Total for Question 17 = 12 marks)



18 A treatment for brain tumours involves firing a beam of pions at the tumour. Pions exist for a very short time. During treatment many pions hit the tumour just as they decay. This causes the cells in the tumour to fragment, which kills them with no harmful effect to the surrounding tissue.

Pions belong to a group of sub-atomic particles called mesons. There are three types of pion: π^- π^+ π^0 .

(a) The following table lists some quarks and their charge.

Quark	Charge/ e
u	+2/3
d	-1/3
s	-1/3
c	+2/3

State a possible quark combination for a π^- .

(1)

(b) Pions are produced when protons, accelerated in a cyclotron, are aimed at a target of beryllium and interact with protons in the beryllium.

Identify the type of pion produced in the following interaction.

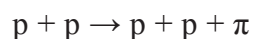

(1)

(c) The π^- mesons used for a treatment have a speed of $2.3 \times 10^8 \text{ m s}^{-1}$ and a range in air of 5.9 m.

Calculate the time for which these π^- mesons exist.

(2)

Time =



*(d) The photograph shows what happens in a Bubble Chamber when some pions enter at the bottom and travel upwards. One pion has been identified by X in the photograph and the simplified line diagram shows the visible tracks of the pion and subsequent decay products.

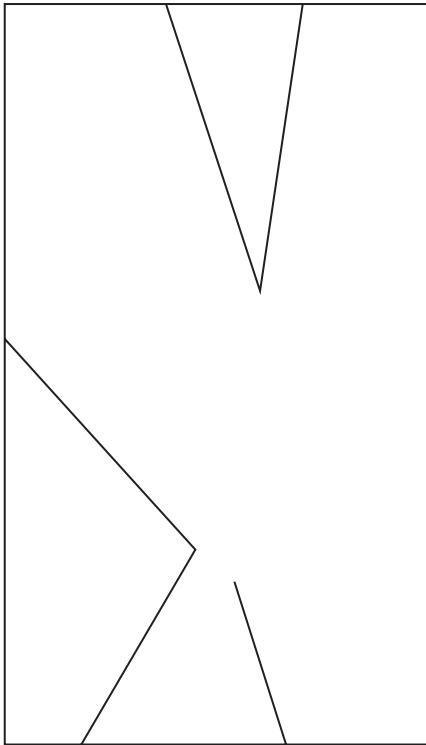

X

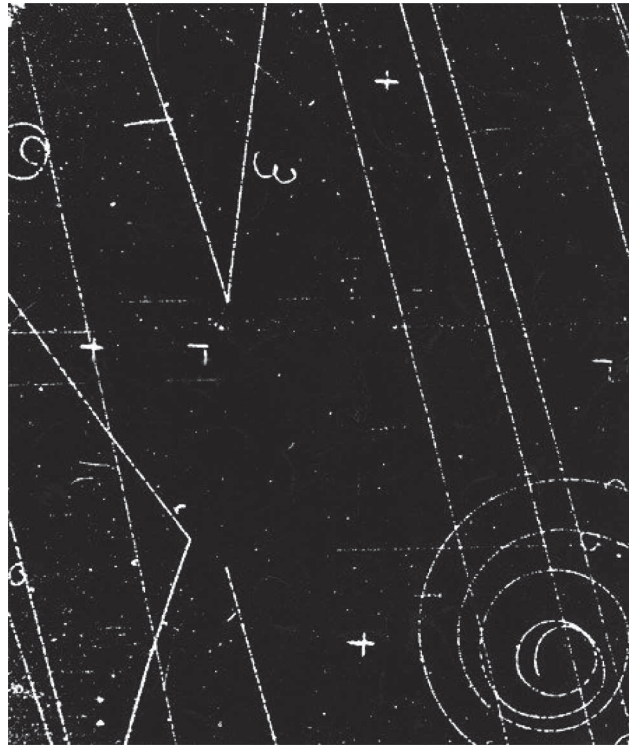

X

Explain what can be deduced about the sequence of the events shown in the line diagram.

(6)

.....

.....

.....

.....

.....

.....

.....

.....

.....

.....

.....

.....

.....

.....

.....

.....

.....

.....

.....

.....

.....

.....



(e) If very high speed protons are fired at beryllium, the following interaction occurs

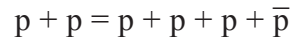

(i) State the name of the particle \bar{p} and give its properties.

(2)

.....

.....

.....

(ii) State what is likely to happen to the \bar{p} particle.

(1)

.....

.....

(Total for Question 18 = 13 marks)

TOTAL FOR SECTION B = 70 MARKS

TOTAL FOR PAPER = 80 MARKS



List of data, formulae and relationships

Acceleration of free fall	$g = 9.81 \text{ m s}^{-2}$	(close to Earth's surface)
Boltzmann constant	$k = 1.38 \times 10^{-23} \text{ J K}^{-1}$	
Coulomb's law constant	$k = 1/4\pi\epsilon_0$ $= 8.99 \times 10^9 \text{ N m}^2 \text{ C}^{-2}$	
Electron charge	$e = -1.60 \times 10^{-19} \text{ C}$	
Electron mass	$m_e = 9.11 \times 10^{-31} \text{ kg}$	
Electronvolt	$1 \text{ eV} = 1.60 \times 10^{-19} \text{ J}$	
Gravitational constant	$G = 6.67 \times 10^{-11} \text{ N m}^2 \text{ kg}^{-2}$	
Gravitational field strength	$g = 9.81 \text{ N kg}^{-1}$	(close to Earth's surface)
Permittivity of free space	$\epsilon_0 = 8.85 \times 10^{-12} \text{ F m}^{-1}$	
Planck constant	$h = 6.63 \times 10^{-34} \text{ J s}$	
Proton mass	$m_p = 1.67 \times 10^{-27} \text{ kg}$	
Speed of light in a vacuum	$c = 3.00 \times 10^8 \text{ m s}^{-1}$	
Stefan-Boltzmann constant	$\sigma = 5.67 \times 10^{-8} \text{ W m}^{-2} \text{ K}^{-4}$	
Unified atomic mass unit	$u = 1.66 \times 10^{-27} \text{ kg}$	

Unit 1

Mechanics

Kinematic equations of motion	$v = u + at$ $s = ut + \frac{1}{2}at^2$ $v^2 = u^2 + 2as$
Forces	$\Sigma F = ma$ $g = F/m$ $W = mg$
Work and energy	$\Delta W = F\Delta s$ $E_k = \frac{1}{2}mv^2$ $\Delta E_{\text{grav}} = mg\Delta h$

Materials

Stokes' law	$F = 6\pi\eta r v$
Hooke's law	$F = k\Delta x$
Density	$\rho = m/V$
Pressure	$p = F/A$
Young modulus	$E = \sigma/\epsilon$ where Stress $\sigma = F/A$ Strain $\epsilon = \Delta x/x$
Elastic strain energy	$E_{\text{el}} = \frac{1}{2}F\Delta x$



Unit 2

Waves

Wave speed $v = f\lambda$

Refractive index ${}_1\mu_2 = \sin i / \sin r = v_1 / v_2$

Electricity

Potential difference $V = W/Q$

Resistance $R = V/I$

Electrical power, energy and efficiency
 $P = VI$
 $P = I^2R$
 $P = V^2/R$
 $W = VI t$

$$\% \text{ efficiency} = \frac{\text{useful energy output}}{\text{total energy input}} \times 100$$

$$\% \text{ efficiency} = \frac{\text{useful power output}}{\text{total power input}} \times 100$$

Resistivity $R = \rho l/A$

Current $I = \Delta Q / \Delta t$
 $I = nqvA$

Resistors in series $R = R_1 + R_2 + R_3$

Resistors in parallel $\frac{1}{R} = \frac{1}{R_1} + \frac{1}{R_2} + \frac{1}{R_3}$

Quantum physics

Photon model $E = hf$

Einstein's photoelectric equation $hf = \phi + \frac{1}{2}mv_{\max}^2$



Unit 4

Mechanics

Momentum	$p = mv$
Kinetic energy of a non-relativistic particle	$E_k = p^2/2m$
Motion in a circle	$v = \omega r$ $T = 2\pi/\omega$ $F = ma = mv^2/r$ $a = v^2/r$ $a = r\omega^2$

Fields

Coulomb's law	$F = kQ_1Q_2/r^2$ where $k = 1/4\pi\epsilon_0$
Electric field	$E = F/Q$ $E = kQ/r^2$ $E = V/d$
Capacitance	$C = Q/V$
Energy stored in capacitor	$W = \frac{1}{2}QV$
Capacitor discharge	$Q = Q_0 e^{-t/RC}$
In a magnetic field	$F = BIl \sin \theta$ $F = Bqv \sin \theta$ $r = p/BQ$
Faraday's and Lenz's Laws	$\epsilon = -d(N\phi)/dt$

Particle physics

Mass-energy	$\Delta E = c^2 \Delta m$
de Broglie wavelength	$\lambda = h/p$



BLANK PAGE



BLANK PAGE

