



Mark Scheme (Results)

Summer 2018

Pearson Edexcel GCSE
In Physics (1PH0) Paper 2H

Edexcel and BTEC Qualifications

Edexcel and BTEC qualifications are awarded by Pearson, the UK's largest awarding body. We provide a wide range of qualifications including academic, vocational, occupational and specific programmes for employers. For further information visit our qualifications websites at www.edexcel.com or www.btec.co.uk. Alternatively, you can get in touch with us using the details on our contact us page at www.edexcel.com/contactus.

Pearson: helping people progress, everywhere

Pearson aspires to be the world's leading learning company. Our aim is to help everyone progress in their lives through education. We believe in every kind of learning, for all kinds of people, wherever they are in the world. We've been involved in education for over 150 years, and by working across 70 countries, in 100 languages, we have built an international reputation for our commitment to high standards and raising achievement through innovation in education. Find out more about how we can help you and your students at: www.pearson.com/uk

Summer 2018

Publications Code 1PH0_2H_1806_MS

All the material in this publication is copyright

© Pearson Education Ltd 2018

General Marking Guidance

- All candidates must receive the same treatment. Examiners must mark the first candidate in exactly the same way as they mark the last.
- Mark schemes should be applied positively. Candidates must be rewarded for what they have shown they can do rather than penalised for omissions.
- Examiners should mark according to the mark scheme not according to their perception of where the grade boundaries may lie.
- There is no ceiling on achievement. All marks on the mark scheme should be used appropriately.
- All the marks on the mark scheme are designed to be awarded. Examiners should always award full marks if deserved, i.e. if the answer matches the mark scheme. Examiners should also be prepared to award zero marks if the candidate's response is not worthy of credit according to the mark scheme.
- Where some judgement is required, mark schemes will provide the principles by which marks will be awarded and exemplification may be limited.
- When examiners are in doubt regarding the application of the mark scheme to a candidate's response, the team leader must be consulted.
- Crossed out work should be marked UNLESS the candidate has replaced it with an alternative response.

Mark schemes have been developed so that the rubrics of each mark scheme reflects the characteristics of the skills within the AO being targeted and the requirements of the command word. So for example the command word 'Explain' requires an identification of a point and then reasoning/justification of the point.

Explain questions can be asked across all AOs. The distinction comes whether the identification is via a judgment made to reach a conclusion, or, making a point through application of knowledge to reason/justify the point made through application of understanding. It is the combination and linkage of the marking points that is needed to gain full marks.

When marking questions with a 'describe' or 'explain' command word, the detailed marking guidance below should be consulted to ensure consistency of marking.

Assessment Objective		Command Word	
Strand	Element	Describe	Explain
AO1*		An answer that combines the marking points to provide a logical description	An explanation that links identification of a point with reasoning/justification(s) as required
AO2		An answer that combines the marking points to provide a logical description, showing application of knowledge and understanding	An explanation that links identification of a point (by applying knowledge) with reasoning/justification (application of understanding)
AO3	1a and 1b	An answer that combines points of interpretation/evaluation to provide a logical description	
AO3	2a and 2b		An explanation that combines identification via a judgment to reach a conclusion via justification/reasoning
AO3	3a	An answer that combines the marking points to provide a logical description of the plan/method/experiment	
AO3	3b		An explanation that combines identifying an improvement of the experimental procedure with a linked justification/reasoning

*there will be situations where an AO1 question will include elements of recall of knowledge directly from the specification (up to a maximum of 15%). These will be identified by an asterisk in the mark scheme.

Question Number	Answer	Mark
1 (a)	<p>C The volume of the air inside the cylinder.</p> <p>The only correct answer is C</p> <p><i>A is not correct because the mass remains unchanged</i> <i>B is not correct because the rate of collision decreases</i> <i>D is not correct because the pressure decreases</i></p>	<p>(1) AO 1 1</p>

Question Number:	Answer	Additional Guidance	Mark
1 (b) (i)	at right angles / 90°	perpendicular / normal to the tube wall	<p>(1) AO 1 1</p>

Question Number:	Answer	Additional Guidance	Mark
1 (b) (ii)	<p>select and substitute into $P_1 \times V_1 = P_2 \times V_2$ (1)</p> <p>$400\,000 \times V_1 = 100\,000 \times 4.8$</p> <p>rearrangement (1)</p> $V_1 = \frac{100\,000 \times 4.8}{400\,000}$ <p>evaluation (1)</p> <p>$(V_1 =) 1.2$ (litres)</p>	<p>substitution and rearrangement in either order</p> <p>award full marks for the correct answer without working</p> <p>POT error 2 marks</p>	<p>(3) AO 2 1</p>

Question Number:	Answer	Additional Guidance	Mark
1 (b) (iii)	<p>an explanation linking:</p> <p>work is done (in compressing the air) (1)</p> <p>increases the kinetic energy of the (air) particles / thermal energy (of the system) (1)</p>	<p>heat for thermal</p> <p>accept answer in terms of $p \Delta V$</p> $W = F \times d$ $= p \times (A \times d)$ $= p \Delta V$	<p>(2) AO 1 1</p>

(Total for Question 1 = 7 marks)

Question Number:	Answer	Additional Guidance	Mark
2(a)(i)	<p>a description to include:</p> <p>(measurement of) the mass of water (1)</p> <p>(measurement of) the temperature (rise/change) (1)</p> <p>(measurement of) the energy supplied / from heater (1)</p> <p>detail of any of the above (1)</p>	<p>accept volume / weight of water ignore amount</p> <p>accept (take) thermometer reading</p> <p>accept (take) reading of the joulemeter</p> <p>ignore 'change in thermal energy' (from equation)</p> <p>e.g. measure temp at the start and end or measure mass of empty cup or start and end readings on the meter</p>	<p>(4) AO 1 2</p>

Question Number:	Answer	Additional Guidance	Mark
2(a)(ii)	<p>any two improvements from:</p> <p>add lid / cover (1)</p> <p>add lagging / insulation (1)</p> <p>add a stirrer (1)</p> <p>use a more sensitive thermometer (1)</p> <p>ensure heater fully submerged (1)</p>	<p>both marks can be scored in one answer space</p> <p>ignore repeating readings ignore increase voltage / power / energy ignore use of clamp to hold thermometer / heater</p> <p>accept use better insulator or better insulated / thicker cup accept use calorimeter</p> <p>ignore use glass beaker unless cup is inside it ignore different type of cup</p> <p>accept use digital / electric thermometer / data logger</p>	<p>(2) AO 3 3b</p>

Question Number:	Answer	Additional Guidance	Mark
2(b)	100 (°C) (1)	accept any answer between and including 95 and 102 (possibility that it is not pure water and possibility of heat loss prevents reaching boiling point)	(1) AO 2 1

Question Number:	Answer	Additional Guidance	Mark
2(c)	substitution (1) $(Q =) \frac{380 \times 3.34 (\times 10^5)}{(1000)}$ evaluation (1) $1.27 \times 10^5 \text{ (J)}$	127 kJ 126920 (J) accept answers that round to 1.27×10^5 e.g. 1.2692×10^5 accept 130 kJ or $1.3 \times 10^5 \text{ (J)}$ POT error max. 1 mark award full marks for correct answer without working	(2) AO 2 1

(Total for Question 2 = 9 marks)

Question Number:	Answer	Additional Guidance	Mark
3(a)	substitution (1) $(KE =) \frac{1}{2} \times 68 \times 12^2$ evaluation (1) 4900 (J)	$\frac{1}{2} \times 68000 \times 12^2$ scores 1 mark accept values that round to 4900(J) e.g. 4896(J) award full marks for correct answer without working	(2) AO 2 1

Question Number:	Answer	Additional Guidance	Mark
3(b)	a description to include: kinetic energy (store) (of cyclist and /or bicycle) decreases / is transferred into(1) thermal energy (store) (of brakes / surroundings) increases (1)	KE for kinetic energy allow heat for thermal allow brakes get hotter ignore sound energy accept kinetic (energy) to heat (energy) for 2 marks in this context	(2) AO 1 1

Question Number:	Answer	Additional Guidance	Mark
3 (c)	<p>recall and substitution (1)</p> $1600 = \text{force} \times 28$ <p>rearrangement (1)</p> $(\text{force}) = \frac{1600}{28}$ <p>evaluation (1)</p> <p>57 (N)</p>	<p>substitution and rearrangement in either order</p> <p>accept f, F or ? for force</p> <p>accept values that round down to 57 e.g. 57.14</p> <p>award full marks for correct answer without working</p> <p>award 1 mark for answers of 44800 or 0.0175 and a correct expression relating work, force and distance</p>	<p>(3) AO 2 1</p>

Question Number:	Answer	Additional Guidance	Mark
3(d)	<p>an explanation linking:</p> <p>over the same time / in 300s, more work done / energy transferred in session 1 than in session 2 (1)</p> <p>(therefore) more power (developed) in session 1 (1)</p>	<p>allow reverse argument</p> <p>power in session 1 = $\frac{45.2}{300} = 0.15$ (kW) or 150(W)</p> <p>allow statement that power = $\frac{\text{work}}{\text{time}}$</p> <p>or</p> <p>power = $\frac{\text{energy(transferred)}}{\text{time}}$</p> <p>for MP1</p> <p>power in session 2 = $\frac{37.9}{300} = 0.13$ (kW) or 126(W)</p>	<p>(2) AO 3 2a AO 3 2b</p>

(Total for Question 3 = 9 marks)

Question Number:	Answer	Additional Guidance	Mark
4(a)(i)	<p>an explanation to link 3 of the following:</p> <p>friction (between cloth and comb) (1)</p> <p>transfer of electrons / charge { from plastic comb / on to the cloth} (1)</p> <p>electrons carry a negative charge (1)</p> <p>leaving excess positive charge on the comb (1)</p>	<p>reference to positive electrons or positive charge moving loses that mark point</p> <p>electrons/charges are rubbed off comb (on to cloth)</p> <p>leaving cloth with negative charge</p> <p>more protons than electrons (on the comb)</p>	(3) AO 2 1

Question Number:	Answer	Additional Guidance	Mark
4(a)(ii)	<p>an explanation linking:</p> <p>a negative charge is induced (1)</p> <p>on the part of the paper closest to the comb (1)</p> <p>opposite charges attract (1)</p>	<p>allow a clear description of induction</p> <p>ignore references to positive charge being moved in this context only</p> <p>force of attraction sufficient to pick up the pieces of paper</p>	(3) AO 2 1

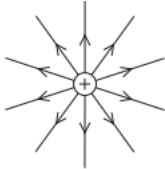
Question Number	Answer	Mark
4(b)	<p>A</p>  <p>The only correct answer is A</p> <p><i>B is not correct because the arrows are in the wrong direction</i></p> <p><i>C is not correct because the field is not circular</i></p> <p><i>D is not correct because the field is not circular</i></p>	(1) AO 1 1

Question Number:	Answer	Additional guidance	Mark
4(c)(i)	<p>an explanation linking:</p> <p>sphere A has an electric field (1)</p> <p>sphere B is in it (1)</p>	<p>both spheres have electric fields</p> <p>the electric fields interact/overlap</p> <p>ignore nature of force; e.g. repulsion</p>	(2) AO 2 2

Question Number:	Answer	Additional Guidance	Mark
4 (c) (ii)	<p>a description to include:</p> <p>as the distance increases the force (on the sphere B) decreases (1)</p> <p>the greatest change is at smallest distances (1)</p>	<p>negative correlation</p> <p>non-linear gradient changes</p> <p>allow named non-linear functions such as exponential / inversely proportional in this context</p> <p>reference to inverse square law scores 2 marks</p>	<p>(2) AO 3 1a AO 3 1b</p>

(Total for Question 4 = 11 marks)

Question Number:	Answer	Additional Guidance	Mark
5(a)	<p>a description to include:</p> <p>method of producing temporary induced magnetism (1)</p> <p>method of demonstrating the magnetic properties of the temporary magnet (1)</p> <p>method of demonstrating magnetic effect is temporary (1)</p>	<p>place iron near / in contact with magnet / in magnetic field</p> <p>OR</p> <p>use magnet to pick up one paper clip</p> <p>OR</p> <p>use magnet to make iron a temporary magnet</p> <p>paper clip(s) attracted to iron</p> <p>OR</p> <p>use first paper clip to pick up another paper clip</p> <p>remove magnet and paper clips no longer attracted / fall off</p> <p>OR</p> <p>wait some / short time and iron bar no longer picks up / attracts paper clips</p>	<p>(3) AO 1 2</p>

Question Number:	Answer	Additional Guidance	Mark
5(b)(i)	<p>a description to include 4 of the following:</p> <ul style="list-style-type: none"> • note position of pointer before current is switched on (1) • measure position of pointer when current in coil (1) • (use an ammeter to) measure current (1) • calculate the extension / stretch of the spring (1) • use force (of attraction) is proportional to extension / stretch (of spring) (1) • repeat with different currents (1) 	<p>measure length of spring before current is switched on</p> <p>how far nail moves</p> <p>calculate force from spring constant and extension</p> <p>calibrate spring</p> <p>increase the current</p> <p>calculate the extension of the spring using new position of pointer minus starting position of pointer is worth 3 marks</p>	<p>(4) AO 2 2</p>

Question Number:	Answer	Additional Guidance	Mark
5(b)(ii)	select and substitute (1) $(E =) \frac{1}{2} \times 24 \times 0.12^2$ evaluation (1) $(E =) 0.17$ (J)	$\frac{1}{2} \times 24 \times 12^2$ max 1 mark accept answers that round down to 0.17 e.g. 0.1728 POT error (e.g. 1728) max 1 mark award full marks for correct answer without working	(2) AO 2 1

(Total for Question 5 = 9 marks)

Question number	Answer		Mark
6(a)(i)	B	1 same as P	(1) AO 1 1
<p>The only correct answer is B</p> <p><i>A is incorrect because the number of teeth on P and R are equal</i></p> <p><i>C is incorrect because Q reverses the rotation of P and then R reverses the rotation of Q</i></p> <p><i>D is incorrect because Q reverses the rotation of P and then R reverses the rotation of Q</i></p>			

Question Number:	Answer	Additional Guidance	Mark
6(a)(ii)	use of distance = pitch x number of teeth (moved) (1) evaluation (1) (distance =) 20 (mm)	allow first mark if 2 x 4 (=8) or 2 x 40 (= 80) seen award full marks for correct answer without working	(2) AO 1 1

Question Number:	Answer	Additional Guidance	Mark
6 (b)	<p>recall clockwise moment = anticlockwise moment (1)</p> <p>moment = force x (perpendicular) distance (1)</p> <p>substitution (1) $m \times 17 = (6 \times 15) + (4.6 \times 10)$</p> <p>rearrangement and evaluation (1)</p> <p>$m = 8.0$ (g)</p>	<p>calculations need not include g (which cancels out from all terms)</p> <p>substitution and rearrangement in either order</p> <p>$m \times 17 = 90 + 46$</p> <p>$m = \frac{(6 \times 15) + (4.6 \times 10)}{17}$</p> <p>$m = 136 / 17$</p> <p>award full marks for correct answer without working</p>	<p>(4) AO 1 1 AO 2 1</p>

Question Number:	Answer	Additional Guidance	Mark
6 (c)	<p>an explanation linking:</p> <p>use of $P = \frac{F}{A}$ (1)</p> <p>area of piston Y is less than area of piston Z (1)</p> <p>(therefore) force K is less than force L (1)</p>	<p>accept answers in terms of work = force x distance</p> <p>accept reverse arguments</p> <p>accept K for piston Y and L for piston Z</p>	<p>(3) AO 3 2a AO 3 2b</p>

(Total for Question 6 = 10 marks)

Question Number:	Answer	Additional guidance	Mark
7(a)(i)	0.9 (k N) (1) up / upwards / ascending (1)	accept .9 or 0.90 north N ↑	(2) AO 3 2a AO 3 2b

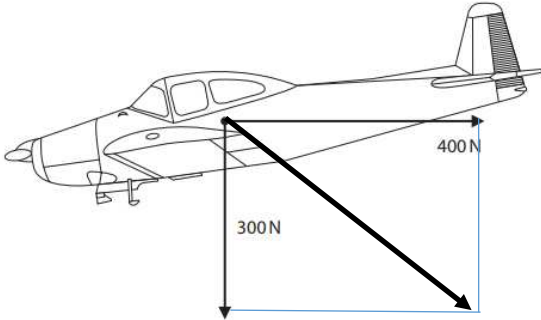
Question Number:	Answer	Additional guidance	Mark
7(a)(ii)		<p>judge length and direction by eye</p> <p>construction lines need not be shown</p> <p>magnitude need not be stated</p> <p>allow missing arrowhead if direction and length are correct</p> <p>reject answers which have any additional vectors drawn</p>	(1) AO 3 2b

Question Number:	Answer	Additional Guidance	Mark
7(a)(iii)	<p>recall and substitution (1)</p> <p>GPE = $750 \times 10 \times 1300$</p> <p>evaluation (1)</p> <p>(energy =) 9 800 000 (J)</p>	<p>no POT error (could have missed out g)</p> <p>allow answers in standard form 9.8×10^6</p> <p>allow answers that round to 9 800 000 e.g. 9 750 000 J</p> <p>allow 9800 kJ or 9.8MJ</p> <p>allow 9 555 000 J</p> <p>allow negative values</p> <p>award full marks for correct answer without working</p>	<p>(2)</p> <p>AO 2 1</p>

Question Number:	Answer	Additional Guidance	Mark
7(b)(i)	<p>recall efficiency equation (1)</p> $\text{efficiency} = \frac{\text{useful output}}{\text{input}}$ <p>rearrangement (1)</p> <p>output energy = 0.70 x 6500</p> <p>recall power equation (1)</p> $\text{power} = \frac{\text{energy}}{\text{time}}$ <p>evaluation (1)</p> <p>(power =) 76 (kW)</p>	$\text{efficiency} = \frac{\text{power output}}{\text{power input}}$ <p>4550 (kJ) seen scores 2 marks (from 0.7 x 6500 (kJ))</p> $\frac{4550}{60}$ <p>accept ecf from output energy</p> <p>accept values that round up to 76 (kW) e.g. 75.8</p> <p>award full marks for correct answer without working</p>	<p>(4) AO 1 1 AO 2 1</p>

Question Number:	Answer	Additional Guidance	Mark
7(b)(ii)	<p>an explanation linking:</p> <p>(useful) output energy is less than input energy (1)</p> <p>some energy is transferred to less useful forms (1)</p>	<p>input energy is greater than output energy</p> <p>(only) 70% of the input energy is useful</p> <p>energy is dissipated / wasted / lost (to surroundings)</p> <p>energy is lost / transferred as thermal / heat</p> <p>30% is lost / dissipated / wasted / lost for 2 marks</p>	<p>(2) AO 1 1</p>

(Total for Question 7 = 11 marks)

Question Number:	Answer	Mark
8(a)(i)	<p>C 6.0 joules per coulomb</p> <p>The only correct answer is C</p> <p><i>A is not correct because 1 volt is 1 joule per coulomb</i> <i>B is not correct because 1 volt is 1 joule per coulomb</i> <i>D is not correct because 1 volt is 1 joule per coulomb</i></p>	<p>(1) AO 1 1</p>

Question Number:	Answer	Additional Guidance	Mark
8(a)(ii)	<p>recall and substitution (1)</p> $42 = \frac{200 \times t}{(1000)}$ <p>rearrangement (1)</p> $t = \frac{42 (\times 1000)}{200 (\times 60)}$ <p>evaluation (1) (t =) 3.5 (minutes)</p>	<p>accept substitution and rearrangement in either order</p> <p>2.1 to any power of 10 or 3.5 to any power of 10 scores 2 marks</p> <p>3 minutes 30 seconds</p> <p>award full marks for correct answer without working</p>	<p>(3) AO 1 1 AO 2 1</p>

Question Number:	Answer	Additional Guidance	Mark
8(a)(iii)	<p>recall and substitution (1)</p> <p>(E =) 42 x 6.0</p> <p>evaluation (1) (energy =) 250 (J)</p>	<p>(using E = VIt)</p> <p>(E =) 6.0 x 200 (x 10⁻³) x 2.10 (x 10²)</p> <p>accept 252 (J)</p> <p>award full marks for correct answer without working</p>	<p>(2) AO 1 1 AO 2 1</p>

Question Number:	Answer	Additional Guidance	Mark
8(b)	<p>an explanation linking:</p> <p>collisions between electrons and lattice (1)</p> <p>lattice { vibrates / moves} more (1)</p>	<p>throughout accept atoms / ions for lattice</p> <p>accept charges / charged particles for electrons</p> <p>allow collision between electrons in this context</p> <p>KE of lattice increases</p> <p>KE of electrons decreases</p>	<p>(2) AO 1 1</p>

Question Number:	Answer	Additional Guidance	Mark
8 (c)	<p>an explanation linking:</p> <p>relevant calculation (1)</p> $R \text{ (between P and Q)} = \frac{6}{1.2} = 5\Omega$ <p>reasoning / interpretation of result (1)</p> <p>this is less than { a single resistor / two resistors in series}</p> <p>conclusion (1)</p> <p>resistors must be connected <u>in parallel</u></p>	<p>allow alternative arguments such as</p> <p>if resistors had been in series, then...</p> $I = \frac{6}{20} = 0.3A$ $V \text{ (between P and Q)} = 1.2 \times 10 = 12V$ <p>current is more (than 0.3A)</p> <p>total p.d. is less than 12 V</p>	<p>(3)</p> <p>AO 3 2a</p> <p>AO 3 2b</p>

(Total for Question 8 = 11 marks)

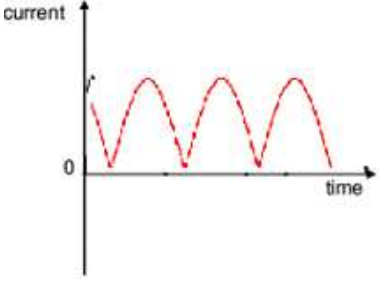
Question Number:	Answer	Mark
9(a)	 <p>B</p> <p>The only correct answer is B</p> <p><i>A is incorrect because it shows an alternating current which is produced by an alternator and not by a dynamo</i></p> <p><i>C is incorrect because it shows a square waveform which is not produced by a dynamo</i></p> <p><i>D is incorrect because it shows current linearly increasing with time and this is not produced by a dynamo</i></p>	(1) AO 3 2b

Question Number:	Answer	Additional Guidance	Mark
9(b)(i)	<p>an explanation linking:</p> <p>(p.d. / current is only induced by a) changing magnetic field (1)</p> <p>a changing current (is needed to create a changing magnetic field) (1)</p>	<p>alternating magnetic field</p> <p>the voltage/current (as shown) is not changing</p>	(2) AO 1 1

Question Number:	Answer	Additional Guidance	Mark
9(b)(ii)	substitution into $\frac{V_P}{V_s} = \frac{N_P}{N_s} \quad (1)$ $\frac{25}{V_s} = \frac{30}{150}$ rearrangement (1) $V_s = \frac{25 \times 150}{30}$ evaluation (1) $(V_s =) \quad 130 \text{ (V)}$	substitution and rearrangement in either order $\frac{V_s}{25} = \frac{150}{30}$ allow 120 or 125 award full marks for correct answer without working	(3) AO 2 1

Question Number	Answer	Mark
* 9(c)	<p>Answers will be credited according to candidate's deployment of knowledge and understanding of the material in relation to the qualities and skills outlined in the generic mark scheme.</p> <p>The indicative content below is not prescriptive and candidates are not required to include all the material which is indicated as relevant. Additional content included in the response must be scientific and relevant.</p> <p style="text-align: center;">AO1(6 marks)</p> <p>Understanding of physics</p> <ul style="list-style-type: none"> • (long) transmission wires have resistance • reduced p.d. at the destination • (thermal) energy is dissipated in the transmission wires • this creates a power loss (refers to $P=I^2R$) • transformers are used to step up to a high voltage for transmission • this means a low current (refers to $V_p I_p = V_s I_s$) • so power loss is small(er) • transformers used to step down to a safer voltage for consumers • consumer wires are shorter and so power loss is less of an issue 	(6) AO 1 1

Level	Mark	Descriptor
	0	<ul style="list-style-type: none"> No rewardable material.
Level 1	1-2	<ul style="list-style-type: none"> An explanation that demonstrates elements of physics understanding, some of which is inaccurate. Understanding of scientific, enquiry, techniques and procedures lacks detail. (AO1) Presents an explanation that is not logically ordered and with significant gaps. (AO1)
Level 2	3-4	<ul style="list-style-type: none"> An explanation that demonstrates physics understanding, which is mostly relevant but may include some inaccuracies. Understanding of scientific ideas, enquiry, techniques and procedures is not fully detailed and/or developed. (AO1) Presents an explanation of the procedure that has a structure which is mostly clear, coherent and logical with minor steps missing. (AO1)
Level 3	5-6	<ul style="list-style-type: none"> An explanation that demonstrates accurate and relevant physics understanding throughout. Understanding of the scientific ideas, enquiry, techniques and procedures is detailed and fully developed. (AO1) Presents an explanation that has a well-developed structure which is clear, coherent and logical. (AO1)

(Total for Question 9 = 12 marks)

Question Number:	Answer	Additional Guidance	Mark
10(a)(i)	1.5 (V)	accept $\frac{12}{8}$ or $\frac{3}{2}$ or $1\frac{1}{2}$	(1) AO 3 1b

Question Number:	Answer	Additional Guidance	Mark
10(a)(ii)	<p>recall and substitution (1)</p> $0.75 = I \times 1.5$ <p>rearrangement (1)</p> $(I =) \frac{0.75}{1.5} (= 0.5)$ <p>recall, substitution and rearrangement (1)</p> $R = \frac{1.5}{0.5}$ <p>evaluation (1)</p> $(R =) 3.0 (\Omega)$	<p>allow ecf from a(i) for all marking points</p> <p>substitution and rearrangement in either order</p> <p>allow ecf of current from MP2 for this mark point only</p> <p>allow other approaches such as $P = \frac{V^2}{R}$ scores 1 mark</p> $0.75 = \frac{1.5^2}{R}$ scores 2 marks $R = \frac{(1.5)^2}{0.75}$ scores 3 marks <p>award full marks for correct answer without working</p>	(4) AO 2 1

Question Number	Answer	Mark
* 10(b)	<p>Answers will be credited according to candidate's deployment of knowledge and understanding of the material in relation to the qualities and skills outlined in the generic mark scheme.</p> <p>The indicative content below is not prescriptive and candidates are not required to include all the material which is indicated as relevant. Additional content included in the response must be scientific and relevant.</p> <p style="text-align: center;">AO1(6 marks)</p> <p>Circuit diagram including</p> <ul style="list-style-type: none"> • power supply • ammeter • voltmeter • filament lamp • means of varying potential difference <p>Description of method</p> <ul style="list-style-type: none"> • measure current with ammeter • measure potential difference with voltmeter • vary the potential difference • calculate the resistance • repeat and compare 	(6) AO 1 2

Level	Mark	Descriptor
	0	<ul style="list-style-type: none"> No rewardable material.
Level 1	1-2	<ul style="list-style-type: none"> An explanation that demonstrates elements of physics understanding, some of which is inaccurate. Understanding of scientific, enquiry, techniques and procedures lacks detail. (AO1) Presents an explanation that is not logically ordered and with significant gaps. (AO1)
Level 2	3-4	<ul style="list-style-type: none"> An explanation that demonstrates physics understanding, which is mostly relevant but may include some inaccuracies. Understanding of scientific ideas, enquiry, techniques and procedures is not fully detailed and/or developed. (AO1) Presents an explanation of the procedure that has a structure, which is mostly clear, coherent and logical with minor steps missing. (AO1)
Level 3	5-6	<ul style="list-style-type: none"> An explanation that demonstrates accurate and relevant physics understanding throughout. Understanding of the scientific ideas, enquiry, techniques and procedures is detailed and fully developed. (AO1) Presents an explanation that has a well-developed structure, which is clear, coherent and logical. (AO1)

(Total for Question 10 = 11 marks)
