



Oxford Cambridge and RSA

Thursday 15 October 2020 – Afternoon

A Level Further Mathematics B (MEI) Y431/01

Mechanics Minor

Time allowed: 1 hour 15 minutes



You must have:

- the Printed Answer Booklet
- the Formulae Booklet for Further Mathematics B (MEI)
- a scientific or graphical calculator

INSTRUCTIONS

- Use black ink. You can use an HB pencil, but only for graphs and diagrams.
- Write your answer to each question in the space provided in the **Printed Answer Booklet**. You can use extra paper if you need to, but you must clearly show your candidate number, the centre number and the question numbers.
- Fill in the boxes on the front of the Printed Answer Booklet.
- Answer **all** the questions.
- Where appropriate, your answer should be supported with working. Marks might be given for using a correct method, even if your answer is wrong.
- Give your final answers to a degree of accuracy that is appropriate to the context.
- The acceleration due to gravity is denoted by $g \text{ m s}^{-2}$. When a numerical value is needed use $g = 9.8$ unless a different value is specified in the question.
- Do **not** send this Question Paper for marking. Keep it in the centre or recycle it.

INFORMATION

- The total mark for this paper is **60**.
- The marks for each question are shown in brackets [].
- This document has **8** pages.

ADVICE

- Read each question carefully before you start your answer.

Answer **all** the questions.

- 1 A uniform solid rectangular prism has cross-section with width w cm and height 24 cm. Another uniform solid prism has cross-section in the shape of an isosceles triangle with width w cm and height h cm. The prisms are both placed with their axes vertical on a rough horizontal plane (see Fig. 1.1, which shows the cross-sections through the centres of mass of both solids).

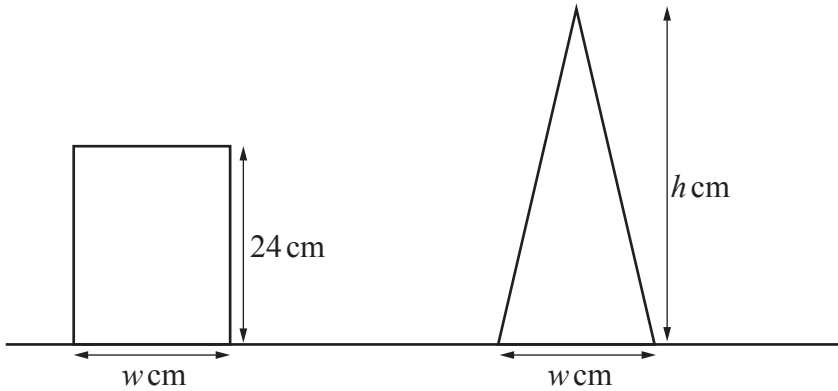

Fig. 1.1

The plane is slowly tilted and both solids remain in equilibrium until the angle of inclination of the plane reaches α , when both solids topple simultaneously.

- (a) Determine the value of h . [2]

It is given that $w = 12$.

- (b) Determine the value of α . [2]

Both prisms are made from the same material and are of uniform density. The triangular prism is now placed on top of the rectangular prism to form a composite body C such that the base of the triangular prism coincides with the top of the rectangular prism. A cross-section of C is shown in Fig. 1.2.

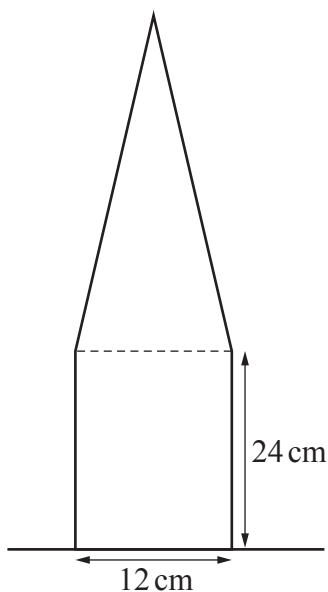

Fig. 1.2

- (c) Determine the height of the centre of mass of C from its base. [2]

- 2 The speed of propagation, c , of a soundwave travelling in air is given by the formula

$$c = kp^\alpha d^\beta,$$

where

- p is the air pressure,
- d is the air density,
- k is a dimensionless constant.

- (a) Use dimensional analysis to determine the values of α and β . [5]

During a series of experiments the speed of propagation of soundwaves travelling in air is initially recorded as 340 m s^{-1} . At a later time it is found that the air pressure has increased by 1% and the air density has fallen by 0.5%.

- (b) Determine, for the later time, the speed of propagation of the soundwaves. [2]

- 3 In this question \mathbf{i} and \mathbf{j} are perpendicular unit vectors and c is a positive real number.

The resultant of two forces $c\mathbf{i}$ N and $-\mathbf{i} + 2\sqrt{c}\mathbf{j}$ N is denoted by R N.

- (a) Show that the magnitude of R is $c + 1$. [2]

A car of mass 900 kg travels along a straight horizontal road with constant resistance to motion of magnitude $(c + 1)$ N. The car passes through point A on the road with speed 6 m s^{-1} , and 8 seconds later passes through a point B on the same road.

The power developed by the car while travelling from A to B is zero. Furthermore, while travelling between A and B, the car's direction of motion is unchanged.

- (b) Determine the range of possible values of c . [3]

The car later passes through a point C on the road. While travelling between B and C the power developed by the car is modelled as constant and equal to 18 kW. The car passes through C with speed 5 m s^{-1} and acceleration 3.5 m s^{-2} .

- (c) Determine the value of c . [3]

- (d) Suggest how one of the modelling assumptions made in this question could be improved. [1]

- 4 A block of mass 20 kg is placed on a rough plane inclined at an angle 30° to the horizontal. The block is pulled up the plane by a constant force acting parallel to a line of greatest slope. The block passes through points A and B on the plane with speeds 9 ms^{-1} and 4 ms^{-1} respectively with B higher up the plane than A. The distance between A and B is $x \text{ m}$ and the coefficient of friction between the block and the plane is $\frac{\sqrt{3}}{49}$.

Use an energy method to determine the range of possible values of x .

[8]

- 5 A uniform rod AB, of mass $3m$ and length $2a$, rests with the end A on a rough horizontal surface. A small object of mass m is attached to the rod at B. The rod is maintained in equilibrium at an angle of 60° to the horizontal by a force acting at an angle of θ to the vertical at a point C, where the distance $AC = \frac{6}{5}a$. The force acting at C is in the same vertical plane as the rod (see Fig. 5).

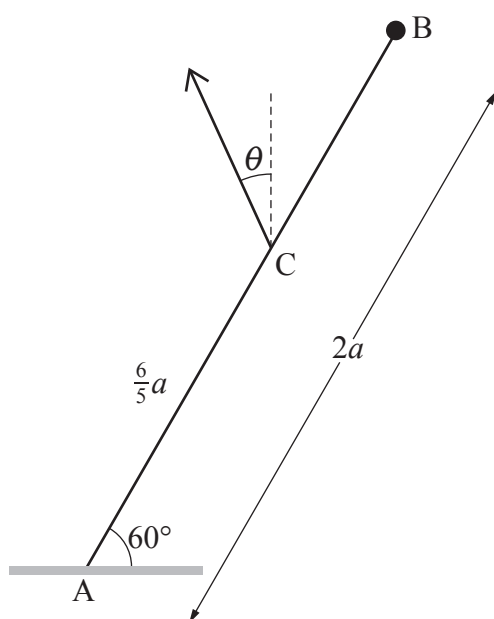

Fig. 5

- (a) On the copy of Fig. 5 in the Printed Answer Booklet, mark all the forces acting on the rod. [2]
- (b) Show that the magnitude of the force acting at C can be expressed as $\frac{25mg}{6(\cos \theta + \sqrt{3} \sin \theta)}$. [4]
- (c) Given that the rod is in limiting equilibrium and the coefficient of friction between the rod and the surface is $\frac{3}{4}$, determine the value of θ . [7]

- 6 Stones A and B have masses m kg and $3m$ kg respectively. They lie at rest on a large area of smooth horizontal ice and may move freely over the ice. Stone A is given a horizontal impulse of magnitude mu N s towards B so that the stones collide directly. After the collision the direction of motion of A is reversed. The coefficient of restitution between A and B is denoted by e .

(a) Find the range of possible values of e . [5]

After the collision, B subsequently collides with a vertical smooth wall perpendicular to its path and rebounds. The coefficient of restitution between B and the wall is the same as the coefficient of restitution between A and B.

(b) Show that A and B will collide again unless the collision between B and the wall is perfectly elastic. [4]

(c) Explain why modelling the collision between B and the wall as perfectly elastic is possibly unrealistic. [1]

(d) Given that the kinetic energy lost in the first collision between A and B is $\frac{5}{24}mu^2$, determine the value of e . [4]

(e) Given that B was 2 metres from the wall when the stones first collided, determine the distance of the stones from the wall when they next collide. [3]

END OF QUESTION PAPER

BLANK PAGE

OCR

Oxford Cambridge and RSA

Copyright Information

OCR is committed to seeking permission to reproduce all third-party content that it uses in its assessment materials. OCR has attempted to identify and contact all copyright holders whose work is used in this paper. To avoid the issue of disclosure of answer-related information to candidates, all copyright acknowledgements are reproduced in the OCR Copyright Acknowledgements Booklet. This is produced for each series of examinations and is freely available to download from our public website (www.ocr.org.uk) after the live examination series.

If OCR has unwittingly failed to correctly acknowledge or clear any third-party content in this assessment material, OCR will be happy to correct its mistake at the earliest possible opportunity.

For queries or further information please contact The OCR Copyright Team, The Triangle Building, Shaftesbury Road, Cambridge CB2 8EA.

OCR is part of the Cambridge Assessment Group; Cambridge Assessment is the brand name of University of Cambridge Local Examinations Syndicate (UCLES), which is itself a department of the University of Cambridge.