

Tuesday 23 May 2017 – Morning

AS GCE PHYSICS B (ADVANCING PHYSICS)

G491/01 Physics in Action

Candidates answer on the Question Paper.

OCR supplied materials:

- Data, Formulae and Relationships Booklet (sent with general stationery)

Other materials required:

- Electronic calculator
- Ruler (cm/mm)

Duration: 1 hour

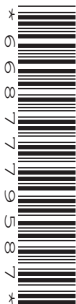

Candidate forename		Candidate surname	
--------------------	--	-------------------	--

Centre number						Candidate number				
---------------	--	--	--	--	--	------------------	--	--	--	--

INSTRUCTIONS TO CANDIDATES

- Write your name, centre number and candidate number in the boxes above. Please write clearly and in capital letters.
- Use black ink. HB pencil may be used for graphs and diagrams only.
- Answer **all** the questions.
- Read each question carefully. Make sure you know what you have to do before starting your answer.
- Write your answer to each question in the space provided. If additional space is required, you should use the lined page(s) at the end of this booklet. The question number(s) must be clearly shown.
- Do **not** write in the barcodes.

INFORMATION FOR CANDIDATES

- The number of marks is given in brackets [] at the end of each question or part question.
- The total number of marks for this paper is **60**.
- You are advised to spend about 20 minutes on Section A and 40 minutes on Section B.
- The values of standard physical constants are given in the Data, Formulae and Relationships Booklet. Any additional data required are given in the appropriate question.
-  Where you see this icon you will be awarded marks for the quality of written communication in your answer.
This means, for example, you should:
 - ensure that text is legible and that spelling, punctuation and grammar are accurate so that meaning is clear;
 - organise information clearly and coherently, using specialist vocabulary when appropriate.
- This document consists of **16** pages. Any blank pages are indicated.

2
SECTION A

1 Here is a list of electrical units.

C Cs⁻¹ C²J⁻¹s⁻¹ JsC⁻² Js⁻¹

Write down from the list the appropriate unit for:

- (a) electric charge
- (b) electrical power
- (c) electrical conductance

[3]

2 Three equal conductors of conductance 20 mS are connected in circuits **A**, **B**, **C** and **D** as shown in Fig. 2.1.

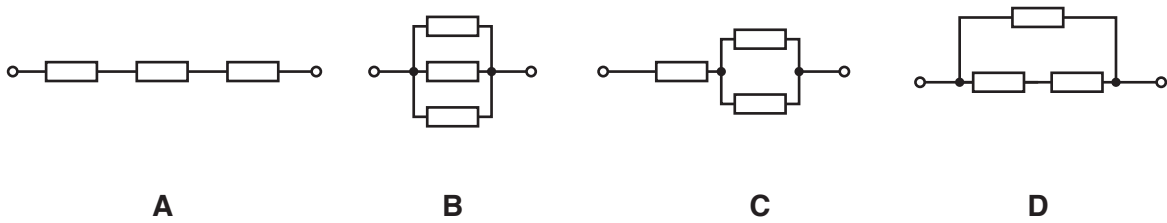

Fig. 2.1

State which of the circuits **A**, **B**, **C** or **D** has:

- (a) the lowest conductance
- (b) a conductance of 13 mS
- (c) a conductance of 6.7 mS

[3]

3 Fig. 3.1 shows the result of plane wavefronts passing through a converging lens.

The lens is replaced with one of the same shape and dimensions, made from a material with a **higher** refractive index (shown in Fig. 3.2).

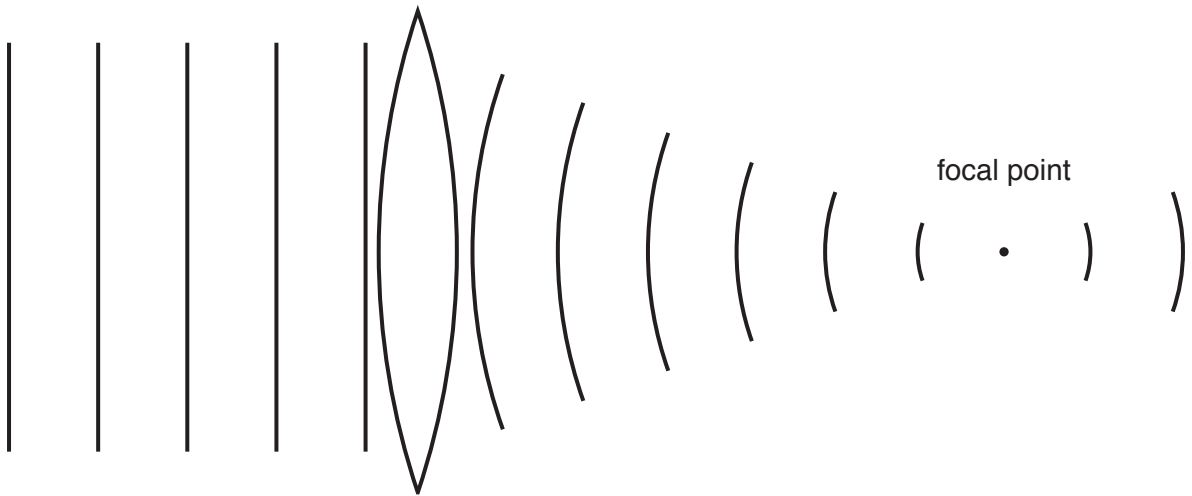

Fig. 3.1

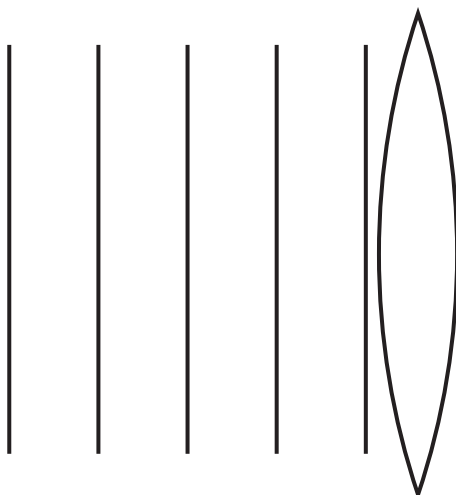

Fig. 3.2 (higher refractive index)

(a) Complete Fig. 3.2 to show the wavefronts to the right of the lens with the **higher** refractive index. [2]

(b) State with a reason whether the power of this lens is larger, smaller or the same as that of the original lens.

.....

.....

.....

..... [1]

- 4 Fig. 4.1 shows two images of the surface of planet Mercury. First it shows a raw noisy image and then an enhanced processed image.

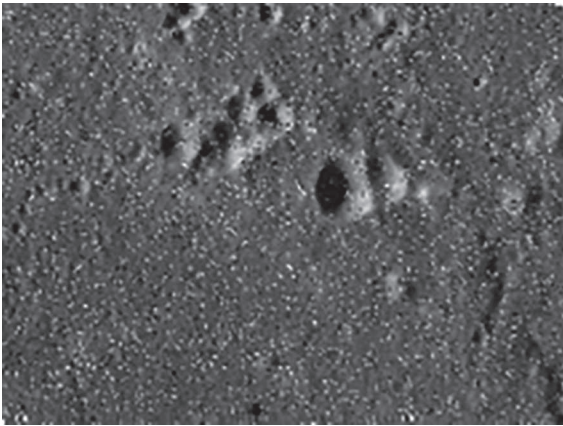

noisy image



processed image

Fig. 4.1

The image was enhanced by replacing the value of each pixel with the median of its value and the values of the surrounding pixels.

- (a) Explain why this process removes the noise.

.....
.....
.....
..... [2]

- (b) Suggest **one** way in which this process may have lost information.

.....
.....
.....
..... [1]

- 5 A single lightning strike delivers 32 C of charge in a time interval of 8.0 ms. Calculate the average current during the strike.

average current = A [2]

- 6 Three equal resistors each of $100\ \Omega$ resistance are connected in the circuit shown in Fig. 6.1.

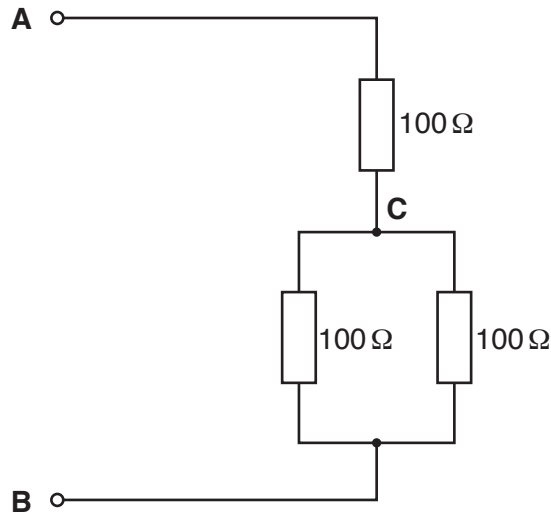

Fig. 6.1

- (a) State the total resistance of the circuit between points **A** and **B**.

resistance = Ω [1]

- (b) A 12V battery of negligible internal resistance is connected between points **A** and **B**.

- (i) Show that the p.d. between **B** and **C** is less than 5 V.

[1]

- (ii) Calculate the power dissipated between **B** and **C**.

power = W [2]

- 7 The refractive index of a type of glass is 1.6.

Calculate the speed of light in this type of glass.

Quote your answer to an appropriate number of significant figures.

speed of light in air = $3.0 \times 10^8 \text{ m s}^{-1}$

speed of light in glass = m s^{-1} [2]

7
BLANK PAGE

PLEASE DO NOT WRITE ON THIS PAGE
Section B starts on page 8

8
SECTION B

- 8** An electrical resistance thermometer consists of a sensor made from a platinum wire. The resistance of the wire increases with temperature.

Temperatures can be measured reliably by monitoring the resistance of the wire.

- (a)** A calibration temperature for the thermometer is melting ice at 0 °C.

The length of the platinum wire is 0.400 m and its radius is 38.0 μm.

Show that the resistance of the platinum wire sensor is about 10 Ω at 0 °C.

resistivity of platinum at 0 °C = $1.10 \times 10^{-7} \Omega \text{ m}$

[3]

- (b)** It is found that the resistance of the sensor increases **linearly** between 0 °C and 100 °C.

At 100 °C the resistance of the sensor is 13.5 Ω.

Draw a calibration graph for the sensor on Fig. 8.1 by displaying its resistance against temperature in the range 0 °C to 100 °C.

Add a suitable temperature scale to the horizontal axis of the graph.

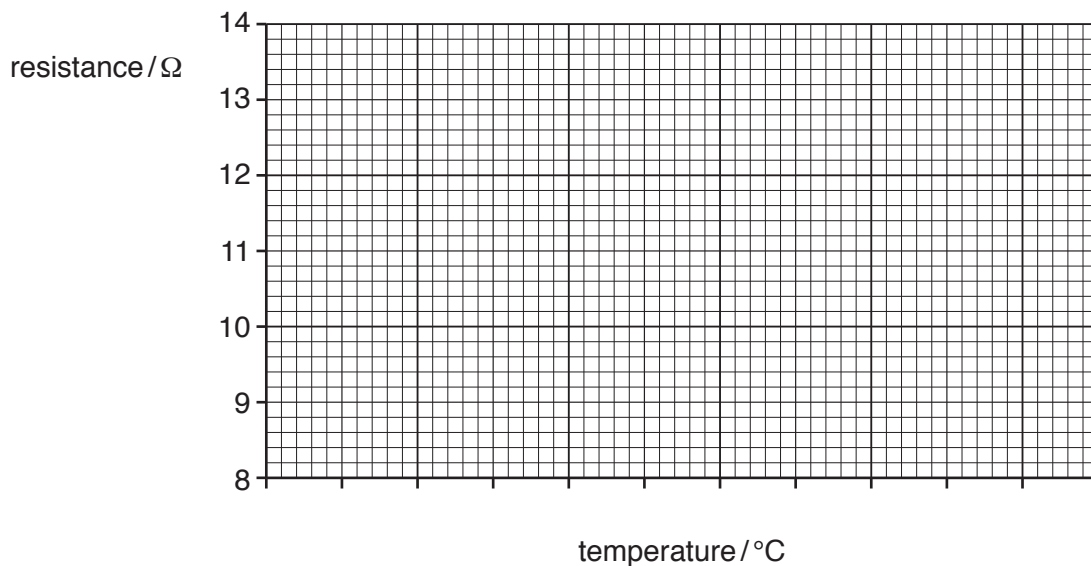

Fig. 8.1

[2]

(c) Using your calibration graph Fig. 8.1

(i) find the resistance of the sensor at a temperature of 45.0 °C.

resistance = Ω [1]

(ii) Estimate the value of the sensitivity of this resistance thermometer.

Make your method clear.

sensitivity = unit [3]

(d) An ohmmeter is used to measure the sensor resistance.

It measures the resistance to an uncertainty of $\pm 0.01 \Omega$.

Calculate the uncertainty in the measurement of temperature over the range 0 °C to 100 °C.

uncertainty in temperature = \pm °C [2]

9 This question is about a mobile phone camera which can record videos.

- (a) The images taken by the phone consist of 1200×900 colour pixels, requiring 24 bits per pixel. In video mode the camera can record and send 15 full colour images per second.

Show that the rate at which information is transmitted when sending the uncompressed video is greater than 350 Mbit s^{-1} .

[1]

- (b) Fig. 9.1 shows how this phone operates, by turning a carrier wave frequency on for 40 complete cycles to represent a 1, and off for 40 cycles to represent a 0.

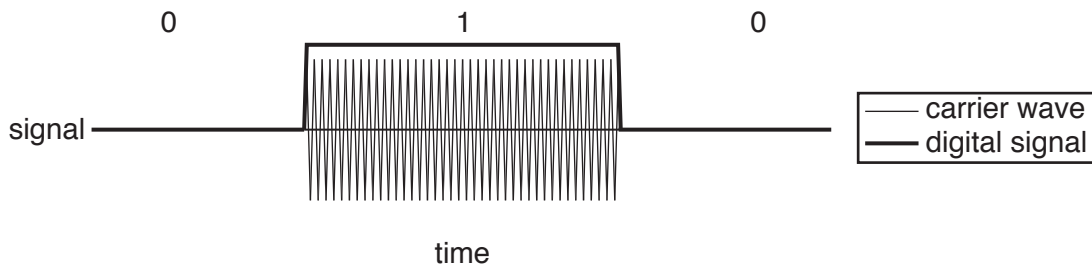

Fig. 9.1

Estimate a minimum suitable carrier frequency for the phone to transmit video information at 350 Mbit s^{-1} .

minimum carrier frequency = Hz [1]

(c) The mobile phone camera also records sound.

The sound signal is sampled at 20 000 samples per second using 12 bits per sample.

(i) Show that the extra rate of transmission of digital data required for the sound information is negligible compared with that needed by the video image data.

[2]

(ii) State the maximum sound frequency that this system can sample successfully, and explain why this is the case.

You may wish to use a diagram in your answer.

maximum frequency = Hz [2]

- (iii) The microphone in the camera produces a total voltage variation up to a maximum of 0.30 V depending on the sound intensity.

The electrical noise voltage variation in the system is at a constant level of $7.3\ \mu\text{V}$.

Suggest with supporting reasoning the value of the total voltage variation when the use of 12 bits per sample is unnecessary and 11 bits per sample would be enough.



You should select and use an appropriate form and style of writing to make your reasoning clear.

[4]

(d) The camera of the video phone takes a focused image of the owner's face when 0.25 m from the fixed focus camera lens.

(i) State the curvature of waves arriving **at the lens** from an object at 0.25 m.

curvature = - D [1]

(ii) The power of the lens in this camera is + 250 D.

Calculate how far this focused image is from the **focal point** of the lens.

distance of image from the focal point = m [4]

10 Fig. 10.1 shows a stress-strain graph for a sample of metal which has been loaded and then unloaded.

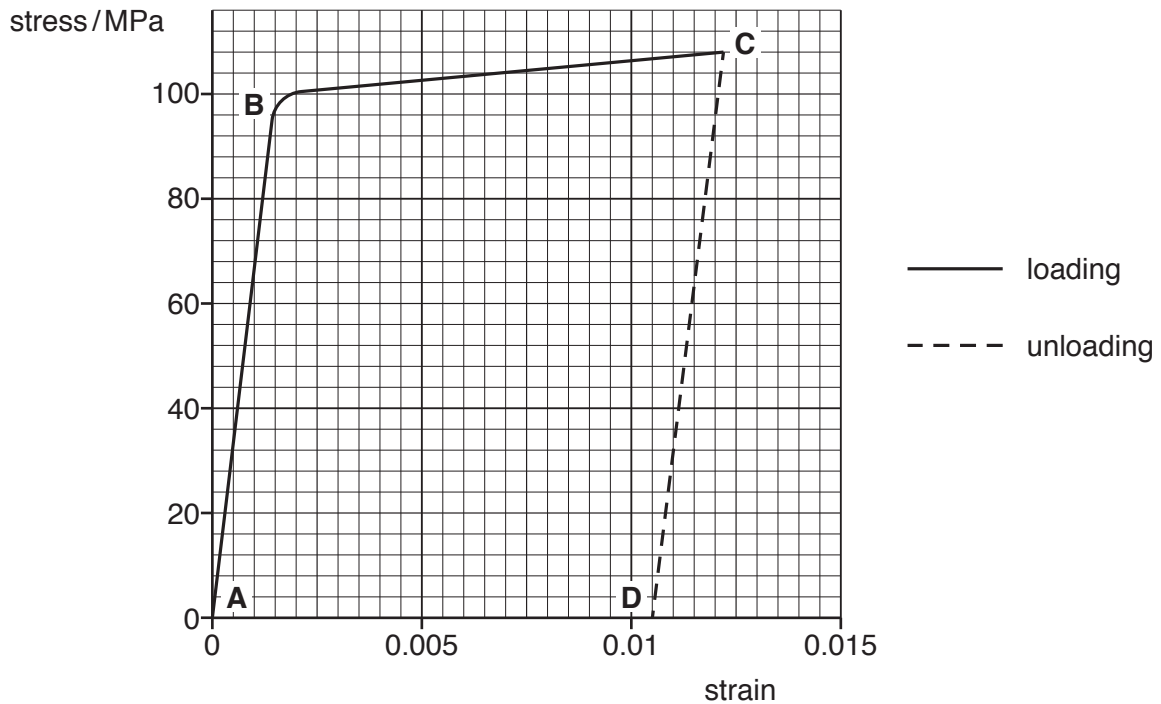

Fig. 10.1

- (a) The graph Fig. 10.1 can be divided into three sections **AB**, **BC** and **CD**.
- (i) Name the section(s) that show **elastic** behaviour
 - (ii) Name the section(s) that show **plastic** behaviour [3]
- (b) Use the graph Fig. 10.1 to complete the statements below.
- (i) The yield stress of the metal is MPa [1]
 - (ii) The permanent strain of the metal after the load is removed is [1]
- (c) The original sample of metal was 2.00 m long.
Calculate the extension of the metal at point **C**.

maximum extension = m [2]

- (d) Calculate the Young modulus of the metal in MPa using data from Fig. 10.1.

Make your method clear.

Young modulus = MPa [3]

- (e) Explain the difference between elastic and plastic behaviour in a metal in terms of the bonding, arrangement and movement of the atoms in a metal.



Organise your answer clearly and coherently using specialist vocabulary.
Labelled diagrams may help to illustrate your answer.

[4]

END OF QUESTION PAPER

ADDITIONAL ANSWER SPACE

If additional space is required, you should use the following lined page(s). The question number(s) must be clearly shown in the margin(s).

A large rectangular area with a vertical solid line on the left side and horizontal dotted lines across the rest of the page, providing space for writing answers.



Copyright Information

OCR is committed to seeking permission to reproduce all third-party content that it uses in its assessment materials. OCR has attempted to identify and contact all copyright holders whose work is used in this paper. To avoid the issue of disclosure of answer-related information to candidates, all copyright acknowledgements are reproduced in the OCR Copyright Acknowledgements Booklet. This is produced for each series of examinations and is freely available to download from our public website (www.ocr.org.uk) after the live examination series. If OCR has unwittingly failed to correctly acknowledge or clear any third-party content in this assessment material, OCR will be happy to correct its mistake at the earliest possible opportunity.

For queries or further information please contact the Copyright Team, First Floor, 9 Hills Road, Cambridge CB2 1GE.

OCR is part of the Cambridge Assessment Group; Cambridge Assessment is the brand name of University of Cambridge Local Examinations Syndicate (UCLES), which is itself a department of the University of Cambridge.