

GCSE (9–1) Mathematics

J560/06 Paper 6 (Higher Tier)

Monday 12 November 2018 – Morning

Time allowed: 1 hour 30 minutes



You may use:

- a scientific or graphical calculator
- geometrical instruments
- tracing paper



First name										
Last name										
Centre number						Candidate number				

INSTRUCTIONS

- Use black ink. You may use an HB pencil for graphs and diagrams.
- Complete the boxes above with your name, centre number and candidate number.
- Answer **all** the questions.
- Read each question carefully before you start to write your answer.
- Where appropriate, your answers should be supported with working. Marks may be given for a correct method even if the answer is incorrect.
- Write your answer to each question in the space provided. If additional space is required, use the lined page(s) at the end of this booklet. The question number(s) must be clearly shown.
- Do **not** write in the barcodes.

INFORMATION

- The total mark for this paper is **100**.
- The marks for each question are shown in brackets [].
- Use the π button on your calculator or take π to be 3.142 unless the question says otherwise.
- This document consists of **24** pages.

Answer **all** the questions.

- 1 In a dance competition, two judges each award scores out of 30. The scatter diagram shows the scores awarded to the first 10 dancers.

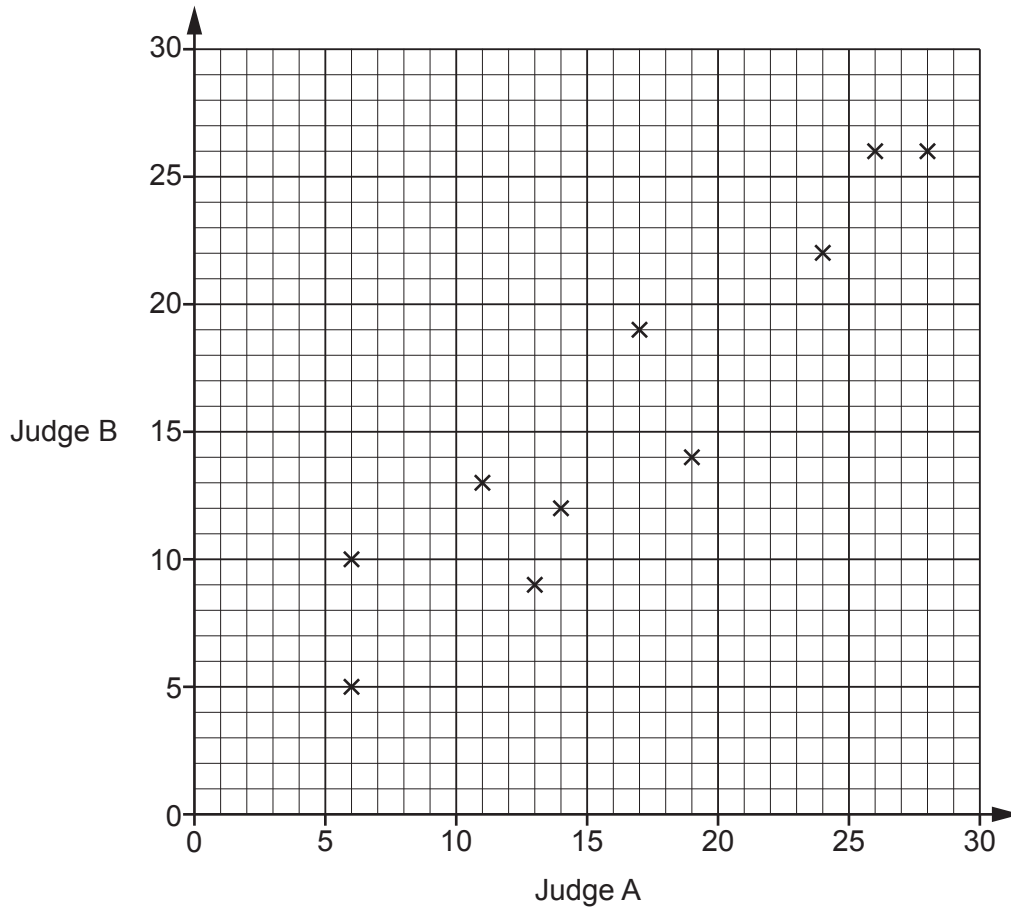

- (a) Here are the scores for the next two dancers.

Judge A	21	7
Judge B	18	8

Plot their scores on the scatter diagram.

[1]

(b) Dancers who are awarded a score of more than 20 by **both** judges receive a medal.

For the 12 dancers, express the ratio of medal winners to non-medal winners in its simplest form.

(b) : [3]

(c) This chart shows the types of dance performed by the 12 dancers.

3 performed a street dance, 8 performed a jazz dance and 1 performed a tap dance.

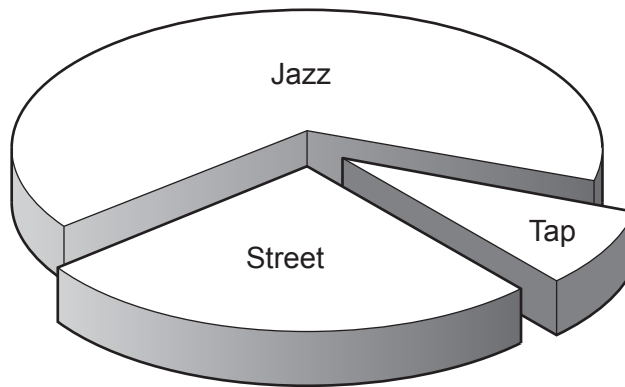

Why is this diagram misleading?

.....
.....
..... [1]

- 2 The police record the speed of vehicles passing a speed checkpoint. The speeds are recorded in the table below.

Speed (s mph)	Number of vehicles		
$0 < s \leq 20$	5		
$20 < s \leq 40$	8		
$40 < s \leq 50$	37		
$50 < s \leq 60$	47		
$60 < s \leq 80$	3		

- (a) Calculate an estimate of the mean speed of the vehicles.

(a) mph [4]

- (b) Explain why it is not possible to use the information from this table to calculate the **exact** value of the mean speed.

.....

 [1]

5

3 A newborn baby has an approximate mass of 3.5 kilograms.

A human cell has an approximate mass of 2.7×10^{-11} grams.

Use these values to estimate the number of human cells in a newborn baby.
Give your answer in standard form, correct to 2 significant figures.

..... [5]

4 Use the symbols $<$, \leq , $=$, $>$, or \geq to complete this statement.

If $x = 4.7$, **truncated** to 1 decimal place, then 4.7 x 4.8 [2]

5 This map shows part of a village.

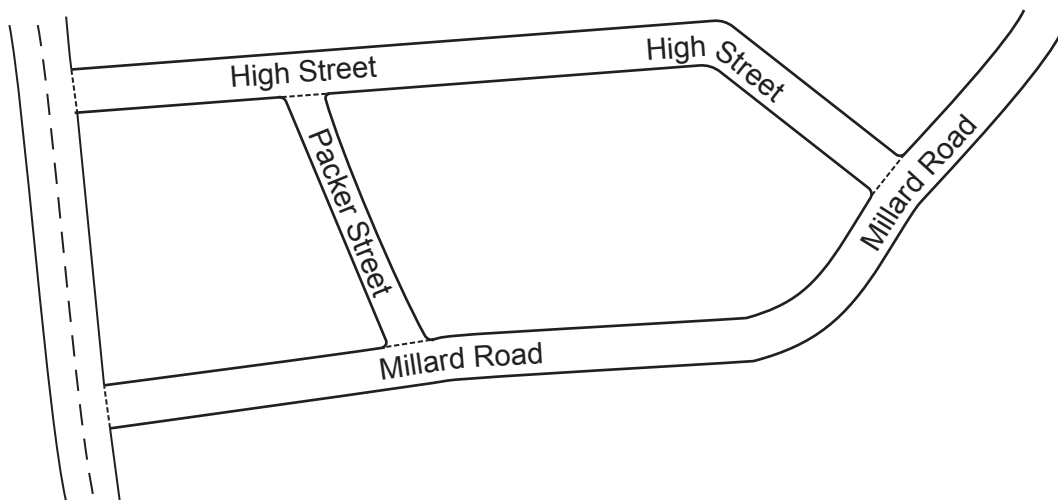

Neil knows that Packer Street is 180m long in real life.

(a) Neil measures the map.

He says

Packer Street is 3.5 cm long.
High Street is 11.2 cm long.

Therefore, I calculate that High Street is 576 m long in real life.

Use Neil's figures to show that the answer to his calculation is correct.

[3]

(b) Jodie measures the same map.

She says

I think Packer Street is longer than Neil's measurement of 3.5 cm.
Therefore, High Street must be longer than 576 m in real life.

Is Jodie's reasoning correct?
Show how you decide.

..... [2]

(c) On another map, Packer Street is 2.4 cm long.

Express the scale of this map in the form 1 : n .

(c) 1 : [2]

- 6 In a box of mixed nuts, the total number of almonds, cashews and peanuts is 1025.
The ratio of almonds to cashews is 1 : 3.
The ratio of cashews to peanuts is 5 : 7.

Calculate the number of cashews in the box.

..... [4]

- 7 The probability that any postcard posted in Portugal on Monday is delivered to the UK within a week is 0.62.
 The probability that any postcard posted in Portugal on Friday is delivered to the UK within a week is 0.41.

- (a) Anna is on holiday in Portugal.
 She posts 15 postcards to the UK on Monday.

How many of her postcards can she expect to be delivered within a week?

(a) [2]

- (b) Sergio is in Portugal.
 He posts one postcard to the UK on Monday.
 He posts another postcard to the UK on Friday.

- (i) Complete the probability tree to show the possible outcomes for the postcards.

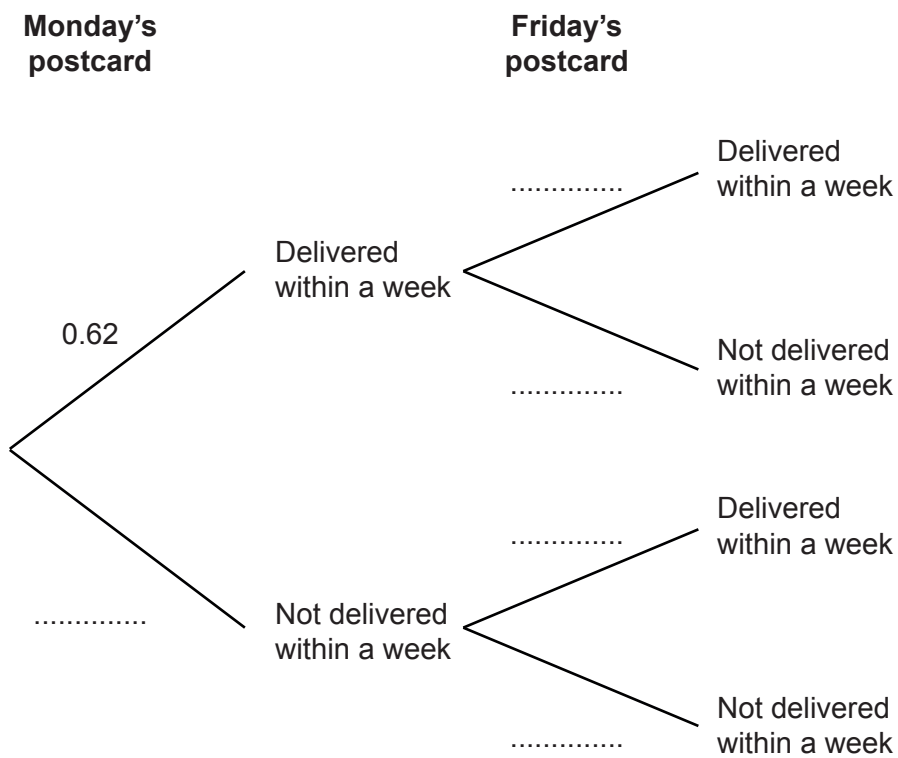

[2]

- (ii) Calculate the probability that only one of Sergio's postcards is delivered within a week.

(b)(ii) [3]

8 The graph shows the speed of a cyclist during 20 seconds of a journey.

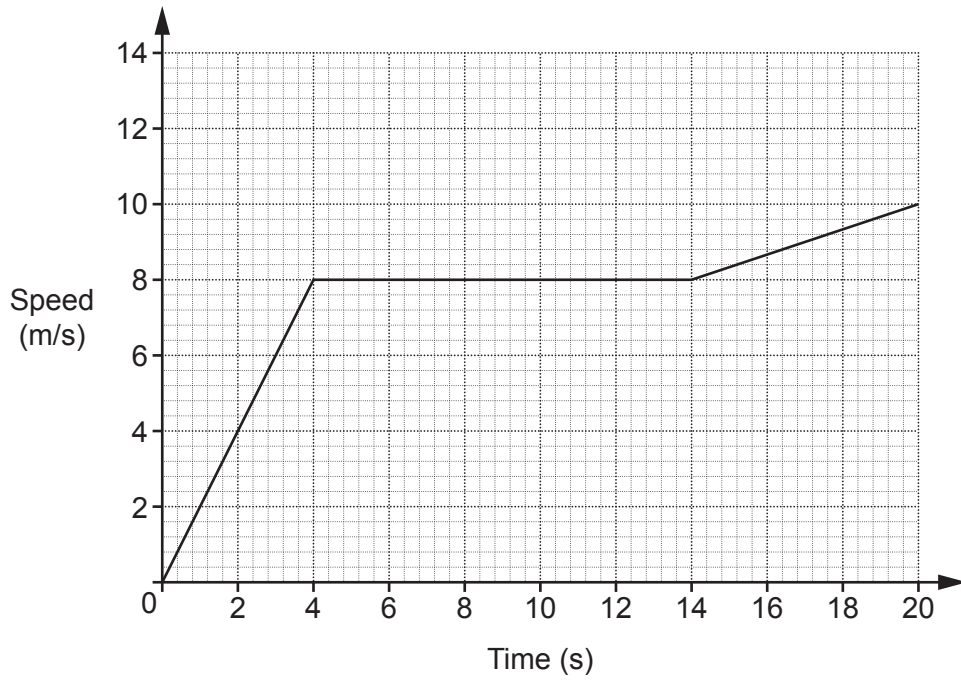

(a) Find the acceleration of the cyclist

(i) for the first 4 seconds

(a)(i) m/s² [2]

(ii) between 4 seconds and 14 seconds.

(ii) m/s² [1]

(b) Work out the distance travelled by the cyclist during the 20 seconds.

(b) m [4]

9 These graphs show different relationships between the variables x and y .

Graph A

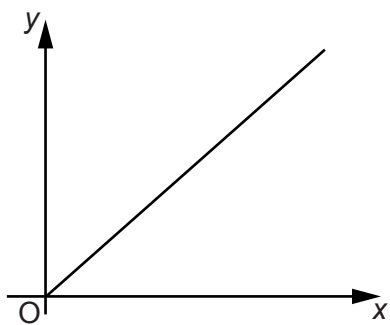

Graph B

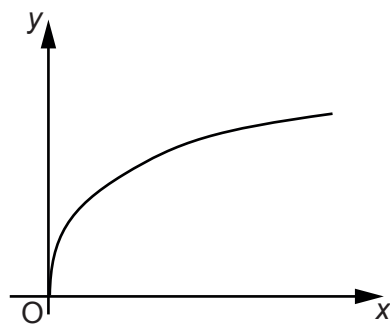

Graph C

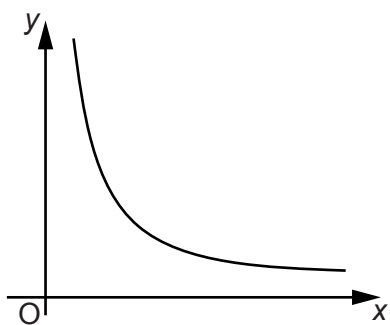

Graph D

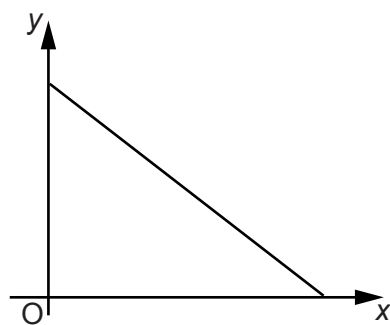

Identify the graph which shows the following.

(a) y is directly proportional to x .

(a) Graph [1]

(b) y is inversely proportional to x .

(b) Graph [1]

10 Sketch a graph which shows that y is directly proportional to x^2 .

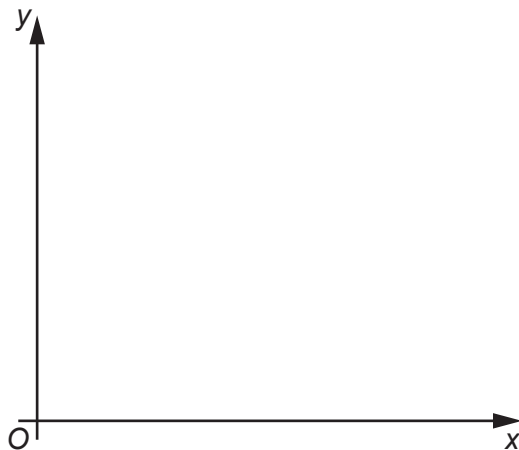

[2]

- 11 A regular polygon has n sides.
The polygon's interior angle is 5 times the size of its exterior angle.

Find n .

$n =$ [5]

- 12 In the diagram, the square and the trapezium share a common side of length x cm.

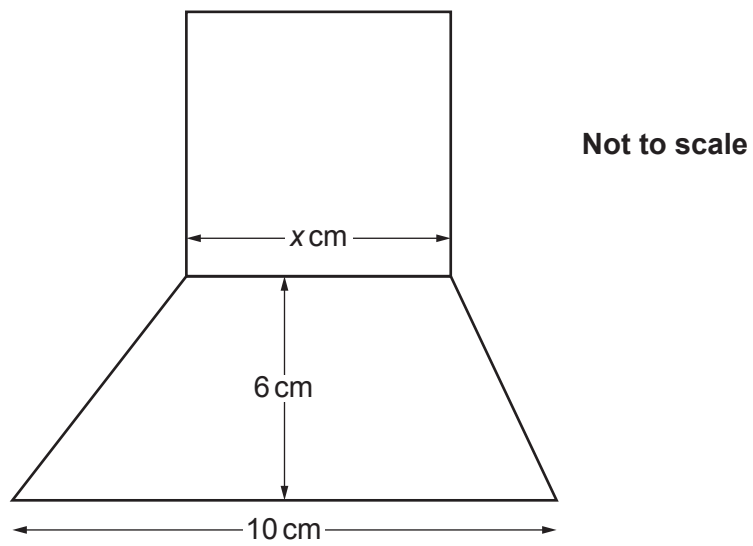

The area of the square is equal to the area of the trapezium.

Work out the value of x .

$x =$

[6]

13 The shape below is formed from two semicircles and a straight line.

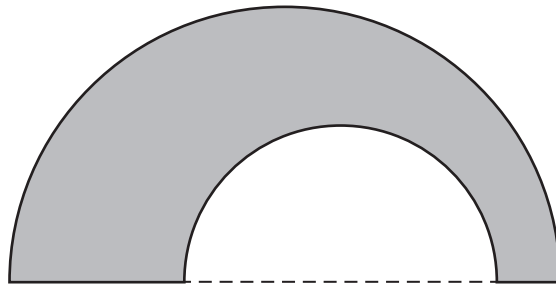

Not to scale

The radius of the large semicircle is 8 cm.
 The radius of the small semicircle is t cm.

Find an expression, in terms of t , for the **exact perimeter** of the shaded shape.

..... cm [3]

14 (a) **Without using a calculator**, show that $0.\dot{1}9$ can be written as $\frac{19}{99}$. [3]

(b) Explain how $\frac{19}{99} = 0.\dot{1}9$ can be used to find $\frac{19}{990}$ as a decimal and write down its value.

.....
 $\frac{19}{990} =$ [2]

- 15 Use the formula $x_{n+1} = \frac{(x_n)^3}{30} + 2$ with $x_1 = 2$ to calculate x_2 and x_3 .
Round your answers correct to 4 decimal places.

$x_2 = \dots\dots\dots$ and $x_3 = \dots\dots\dots$ [3]

- 16 A £1 coin weighs 8.75 g, correct to the nearest 0.01 g.
Mitul weighs the contents of a large bag of £1 coins.
The coins weigh 2.63 kg, correct to the nearest 10 g.

Mitul says

I am sure that the bag contains exactly £300 because, using bounds,
 $2625 \div 8.755 = 299.8$ to 1 decimal place.

Show that Mitul may not be correct.

.....

..... [3]

- 17 Find the exact coordinates of the two intersections of the line $y = 2x$ and the circle $x^2 + y^2 = 30$.

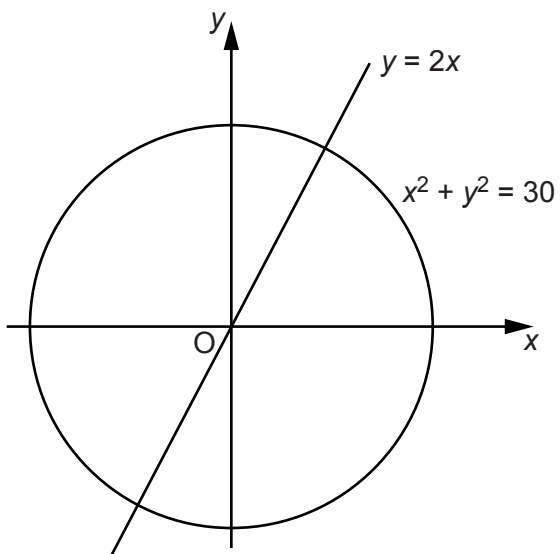

Not to scale

(..... ,) and (..... ,) [5]

18 (a) Sketch the graph of $y = \cos x + 1$ for $0^\circ \leq x \leq 720^\circ$.

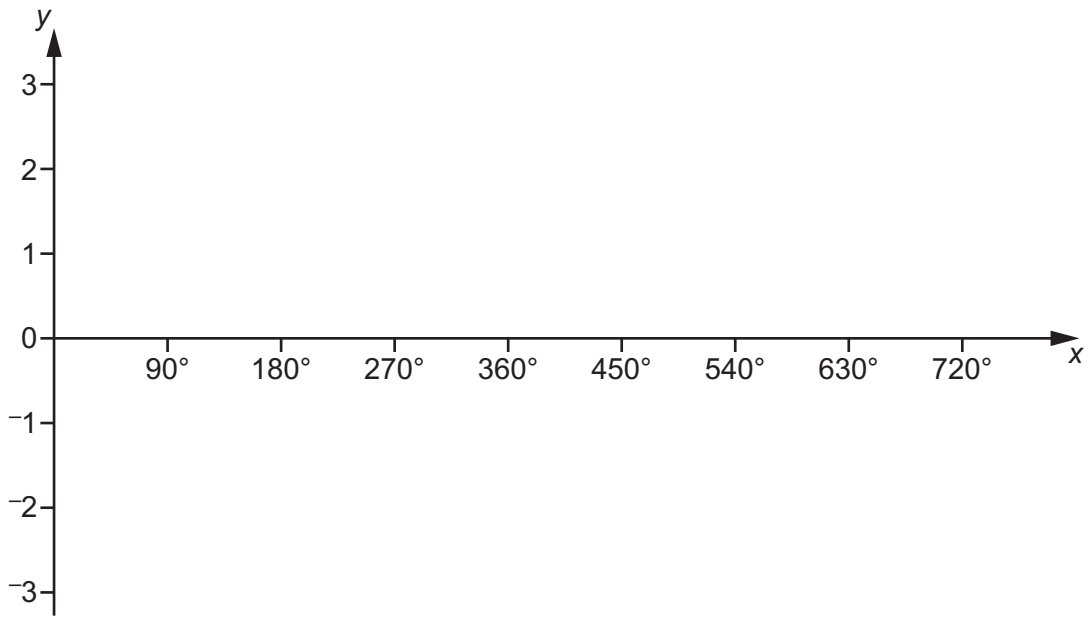

[3]

(b) Explain why the equation $\cos x + 1 = 2.7$ has no solutions.

.....

.....

..... [1]

19 In this triangle:

- $AB = 9 \text{ cm}$
- $AC = 10 \text{ cm}$
- $BC > 5 \text{ cm}$
- $\text{angle } BCA = 60^\circ$
- $\text{angle } ABC < 90^\circ$.

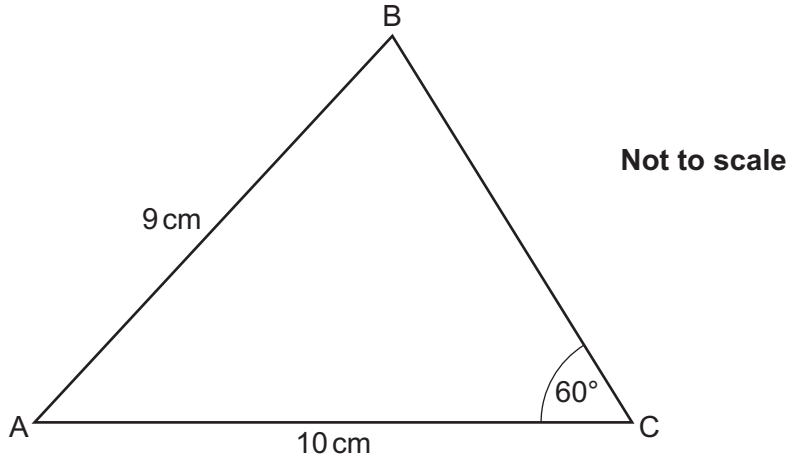

Calculate the area of triangle ABC.

..... cm^2 [6]

Turn over

20 (a) \mathbf{b} is a vector.

Given that $\mathbf{b} + \begin{pmatrix} 5 \\ 2 \end{pmatrix}$ is parallel to $\begin{pmatrix} 2 \\ 1 \end{pmatrix}$, find two possible answers for \mathbf{b} .

$$(a) \mathbf{b} = \begin{pmatrix} \quad \\ \quad \end{pmatrix} \text{ or } \begin{pmatrix} \quad \\ \quad \end{pmatrix} \quad [3]$$

(b) Given that

$$m \begin{pmatrix} 4 \\ 1 \end{pmatrix} + n \begin{pmatrix} 5 \\ 2 \end{pmatrix} = \begin{pmatrix} 12 \\ 6 \end{pmatrix}$$

find the value of m and the value of n .

$$(b) \quad m = \dots\dots\dots$$

$$n = \dots\dots\dots [5]$$

21 Show that $\frac{5x}{x+5} + \frac{25}{x-7} - \frac{300}{(x+5)(x-7)}$ simplifies to an integer.

[6]

END OF QUESTION PAPER

ADDITIONAL ANSWER SPACE

If additional space is required, you should use the following lined page(s). The question number(s) must be clearly shown in the margin(s).

A large area of lined paper for writing. It features a vertical solid line on the left side, creating a margin. The rest of the page is filled with horizontal dotted lines, providing space for writing answers.

A large rectangular area with a solid vertical line on the left side and horizontal dotted lines across the rest of the page, intended for writing answers.



Copyright Information

OCR is committed to seeking permission to reproduce all third-party content that it uses in its assessment materials. OCR has attempted to identify and contact all copyright holders whose work is used in this paper. To avoid the issue of disclosure of answer-related information to candidates, all copyright acknowledgements are reproduced in the OCR Copyright Acknowledgements Booklet. This is produced for each series of examinations and is freely available to download from our public website (www.ocr.org.uk) after the live examination series.

If OCR has unwittingly failed to correctly acknowledge or clear any third-party content in this assessment material, OCR will be happy to correct its mistake at the earliest possible opportunity.

For queries or further information please contact The OCR Copyright Team, The Triangle Building, Shaftesbury Road, Cambridge CB2 8EA.

OCR is part of the Cambridge Assessment Group; Cambridge Assessment is the brand name of University of Cambridge Local Examinations Syndicate (UCLES), which is itself a department of the University of Cambridge.