

Friday 14 June 2019 – Morning GCSE (9–1) Physics A (Gateway Science)

J249/04 Paper 4 (Higher Tier)

Time allowed: 1 hour 45 minutes



You must have:

- a ruler (cm/mm)
- the Data Sheet (for GCSE Physics A (inserted))

You may use:

- a scientific or graphical calculator
- an HB pencil



Please write clearly in black ink. **Do not write in the barcodes.**

Centre number

--	--	--	--	--

Candidate number

--	--	--	--

First name(s)

Last name

INSTRUCTIONS

- The data sheet will be found inside this document.
- Use black ink. You may use an HB pencil for graphs and diagrams.
- Answer **all** the questions.
- Where appropriate, your answers should be supported with working. Marks may be given for a correct method even if the answer is incorrect.
- Write your answer to each question in the space provided. If additional space is required, use the lined page(s) at the end of this booklet. The question number(s) must be clearly shown.

INFORMATION

- The total mark for this paper is **90**.
- The marks for each question are shown in brackets [].
- Quality of extended responses will be assessed in questions marked with an asterisk (*).
- This document consists of **32** pages.

2
SECTION A

You should spend a maximum of 30 minutes on this section.

Answer **all** the questions.

Write your answer to each question in the box provided.

- 1** A sound wave travels in air and enters water.

What happens to the sound wave as it enters the water?

	Speed	Frequency	Wavelength
A	decreases	decreases	decreases
B	decreases	stays the same	decreases
C	increases	increases	increases
D	increases	stays the same	increases

Your answer

[1]

- 2** An electromagnetic wave transfers energy.

Which row in the table is correct?

	Electromagnetic wave	Energy transfer
A	Infra-red	From a heating element of a toaster to the bread inside
B	Radio	From a radio to a transmitter
C	Gamma rays	From a high voltage supply to heating water in food
D	X-rays	From bones in the body to an X-ray machine

Your answer

[1]

- 3** Which waves can damage cells and cause cancer?

- A** Radio, X-rays and infra-red.
- B** Sound, gamma-rays and microwaves.
- C** Sound, visible light and ultraviolet.
- D** Ultraviolet, gamma-rays and X-rays.

Your answer

[1]

4 Which row in the table shows realistic speeds?

Speed (m/s)			
	Road cyclist	Gale force wind	Sound in air
A	40	12	1 000
B	6	24	340
C	20	6	760
D	15	55	250

Your answer

[1]

5 The table gives some information about four radioactive isotopes.

Which isotope is the best to use as a medical tracer?

	Half life	Radiation emitted
A	6 hours	alpha
B	6 hours	gamma
C	6 minutes	gamma
D	6 years	beta

Your answer

[1]

6 The table contains descriptions of wavelength and frequency.

Which row in the table is correct?

	Wavelength	Frequency
A	Distance between a peak and its neighbouring trough.	Number of waves that go past a point in a second.
B	Distance between neighbouring peaks.	Number of waves that go past a point in a second.
C	Distance between neighbouring troughs.	Time period in seconds.
D	Height of the wave.	Number of waves produced.

Your answer

[1]

7 Which statement shows energy resources that are **all renewable**?

- A Bio-fuel, wind, hydro-electricity and tides.
- B Fossil fuels, bio-fuel, wind and hydro-electricity.
- C Fossil fuels, nuclear fuel, hydro-electricity and tides.
- D Nuclear fuel, bio-fuel, wind and tides.

Your answer

[1]

8 Which statement is **true** for isotopes of the same element?

N_p = number of protons and N_n = number of neutrons.

- A $N_p = N_n$
- B N_p is the same but N_n is different
- C N_p is always greater than N_n
- D The total ($N_p + N_n$) is always the same

Your answer

[1]

9 The table contains statements about red-shift and galaxies.

Which row in the table is correct?

	Statement 1	Statement 2
A	All galaxies move apart at the same speed.	They show both red-shift and blue-shift.
B	Distant galaxies show more red-shift.	The distant galaxies are moving apart faster than nearby ones.
C	Distant galaxies show more red-shift.	The distant galaxies are moving apart slower than nearby ones.
D	There are no galaxies that show blue-shift.	All galaxies are moving away from each other.

Your answer

[1]

10 All bodies emit electromagnetic radiation.

Body **R** is at a higher temperature than body **S**.

Which statement is correct?

- A **R** emits radiation with a mean higher frequency.
- B **R** emits radiation with a mean longer wavelength.
- C **S** emits radiation with a higher intensity.
- D **S** emits radiation with a mean shorter wavelength.

Your answer

[1]

11 Planet Ocra is in a circular orbit around a star.

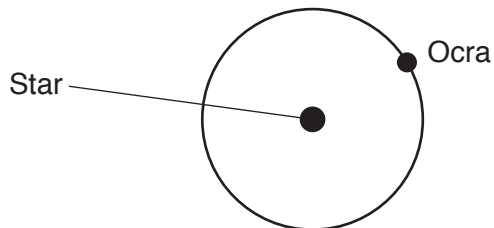

Which statement is correct?

- A The acceleration of Ocra is zero.
- B The speed of Ocra is changing.
- C The velocity of Ocra is changing.
- D The velocity of Ocra is zero.

Your answer

[1]

- 12 An artificial satellite orbits the Earth in a circular path.

The satellite is moved further away from Earth to another orbit.

Which row in the table is correct?

	Force of gravity	Speed in orbit	Time period
A	decreases	decreases	decreases
B	decreases	decreases	increases
C	decreases	increases	increases
D	increases	increases	increases

Your answer

[1]

- 13 This is a diagram of a transformer used in the national grid.

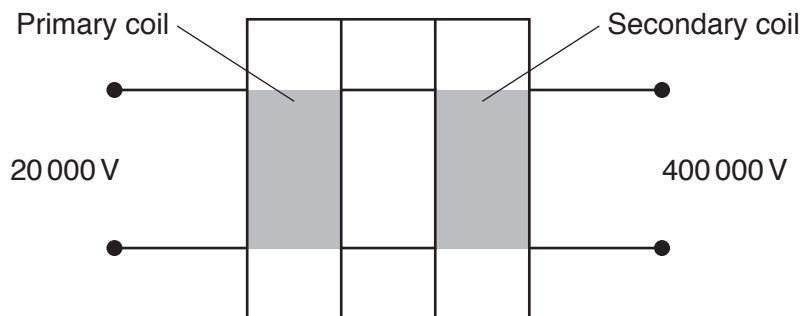

Why is this transformer used in the national grid?

- A To decrease the power in the national grid by a factor of 20.
- B To decrease the power loss in the national grid by a factor of 400.
- C To increase the power in the national grid by a factor of 20.
- D To increase the power loss in the national grid by a factor of 400.

Your answer

[1]

14 A boiler has an input power of 12 kW from the gas it burns.

Its efficiency is 0.75.

Which row in the table shows the correct values for this boiler?

	Useful output power (kW)	Wasted output power (kW)
A	3	9
B	8	4
C	9	6
D	9	3

Your answer

[1]

15 A car has a mass of 1000 kg and a kinetic energy of 12 500 J.

Calculate its speed.

Use the equation: kinetic energy = $0.5 \times \text{mass} \times (\text{speed})^2$

A 3.5 m/s

B 5.0 m/s

C 6.3 m/s

D 25.0 m/s

Your answer

[1]

8
BLANK PAGE

PLEASE DO NOT WRITE ON THIS PAGE

SECTION B

Answer **all** the questions.

- 16 (a) A TV has a power rating of 0.2 kW.

Calculate the energy transferred, in kWh, if the TV is switched on for 4 hours.

Energy transferred = kWh [3]

- (b) A different TV works with a 12.0 V battery. It has a current of 3.19 A.

Calculate the power rating of the TV.

Power = W [3]

17 The graph shows thinking and braking distances for a car at different speeds.

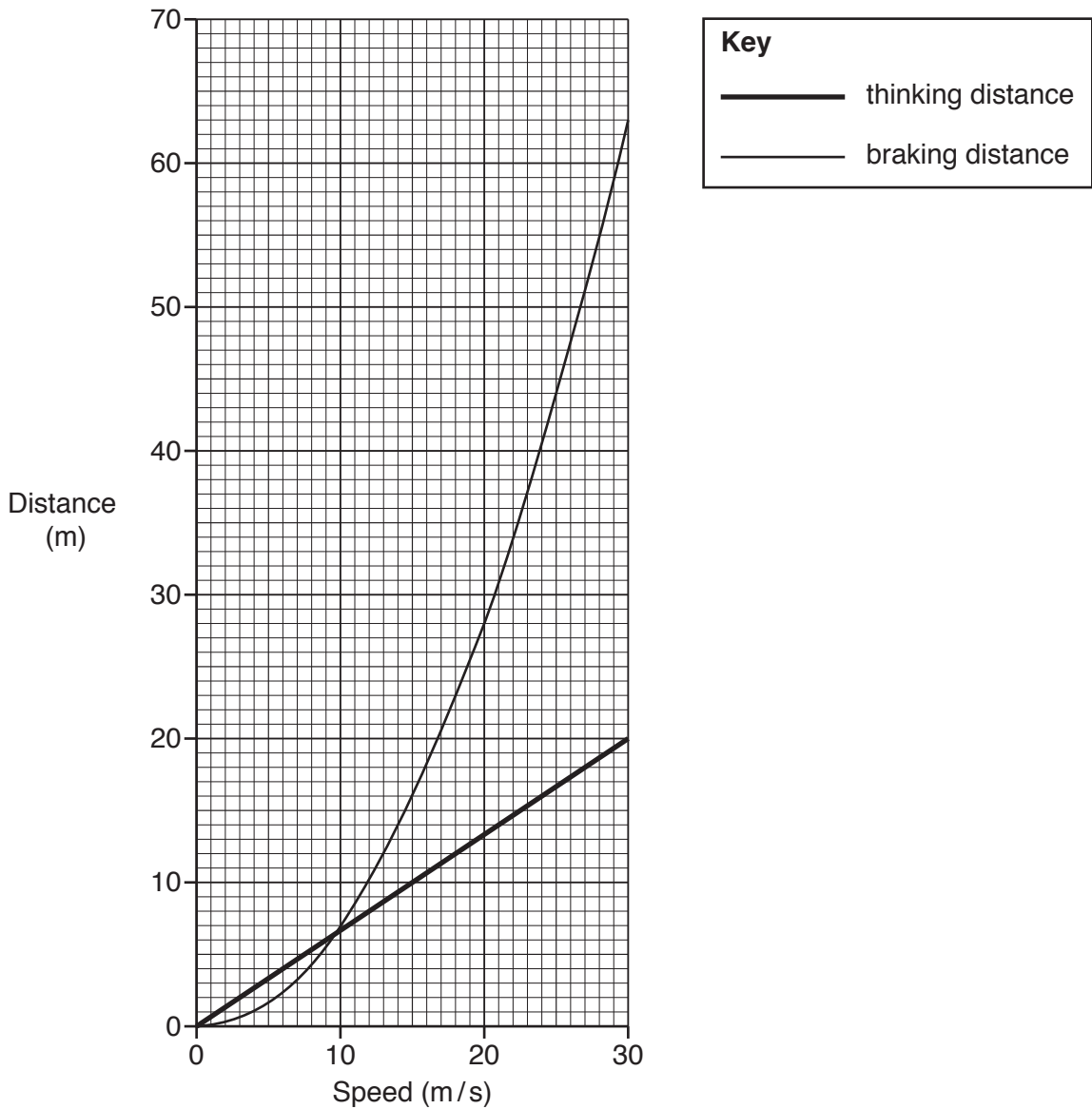

(a) Describe how **thinking distance** varies with increasing speed.

Use data from the graph in your answer.

.....

.....

.....

..... [2]

(b) (i) Use the graph to find the **thinking distance** at 24 m/s.

Thinking distance = m [1]

(ii) Calculate the **thinking time** at 24 m/s.

Use your answer to (b)(i) and the equation: distance travelled = speed × time

Give your answer to **2** decimal places.

Thinking time = s [3]

(c) (i) State **one** factor that could **increase** thinking distance.

..... [1]

(ii) Calculate the **stopping distance** at 15 m/s.

Use the graph to help you.

Stopping distance = m [2]

(d) How does the speed affect the **kinetic energy** and **braking distance** of the car?

Use the graph in your answer.

.....
.....
.....
.....
..... [3]

18 A student investigates reflection and refraction of light rays.

(a) The student sends a ray of red light into a glass prism.

Fig. 18.1 shows the light ray as it leaves the glass prism.

On Fig. 18.1 complete the ray of light as it travels towards **and** through the glass prism.

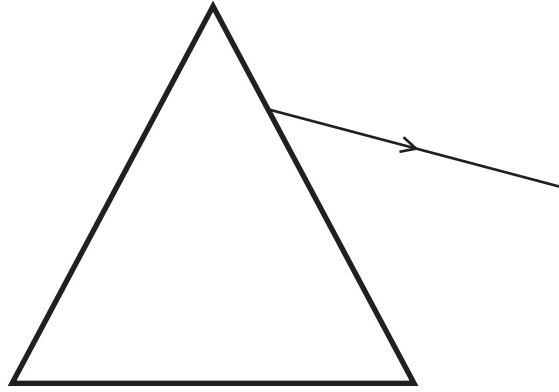

Fig. 18.1

[2]

(b) Fig. 18.2 shows two mirrors placed at 90° to each other.

A light ray hits one of the mirrors at 45° .

On Fig. 18.2 complete the ray of light as it reflects from both mirrors.

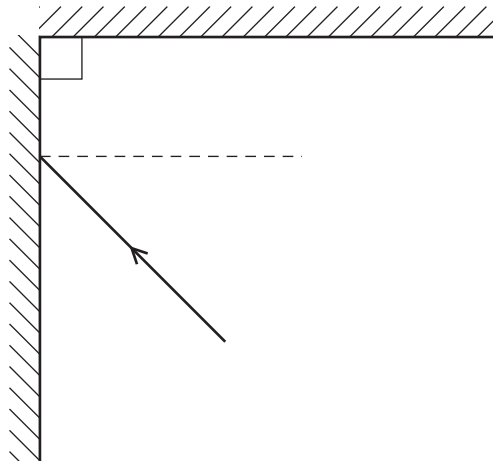

Fig. 18.2

[2]

(c) White light is made of different colours.

White light passes through a transparent filter **X**.

Filter **X** absorbs green, blue, indigo and violet light.

The light then passes through another transparent filter **Y**, as shown in **Fig. 18.3**.

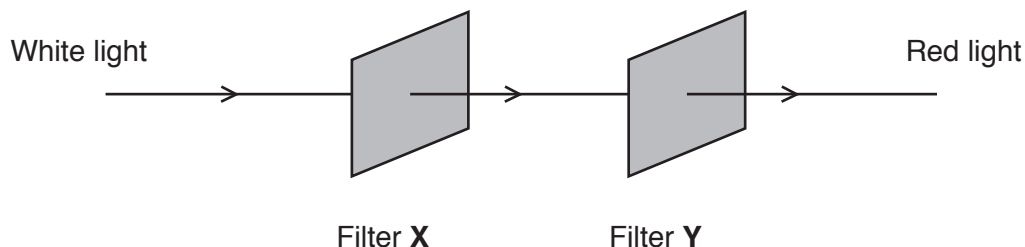

Fig. 18.3

The light that leaves filter **Y** is red.

(i) What colours are transmitted by filter **X**?

.....

 [1]

(ii) What colours are absorbed by filter **Y**?

.....

 [1]

(d) A wall is painted red.

When some coloured lights shine on it, the wall appears black.

(i) Explain why.

.....
 [1]

(ii) Suggest **two** different colours of light that would cause the wall to appear black.

..... **and** [1]

(e) An optician uses red and green light to test vision.

Fig. 18.4 is a ray diagram showing **red light** passing through a lens.

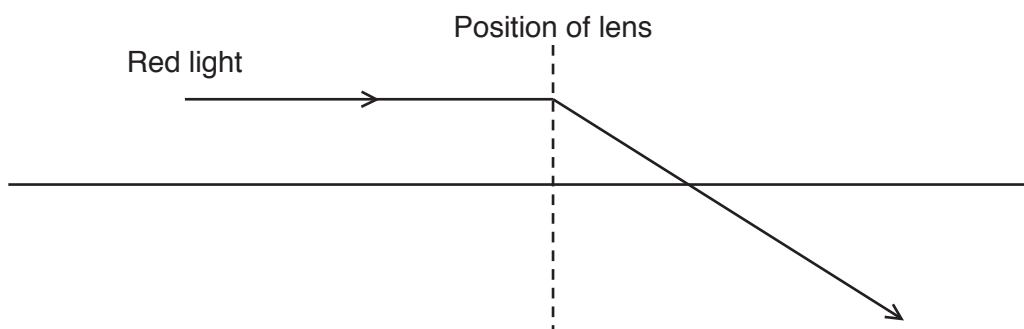

Fig. 18.4

(i) Green light passes through the same lens as in Fig. 18.4.

Complete the ray diagram in Fig. 18.5 for **green light**. The focal point for red light F_R is shown.

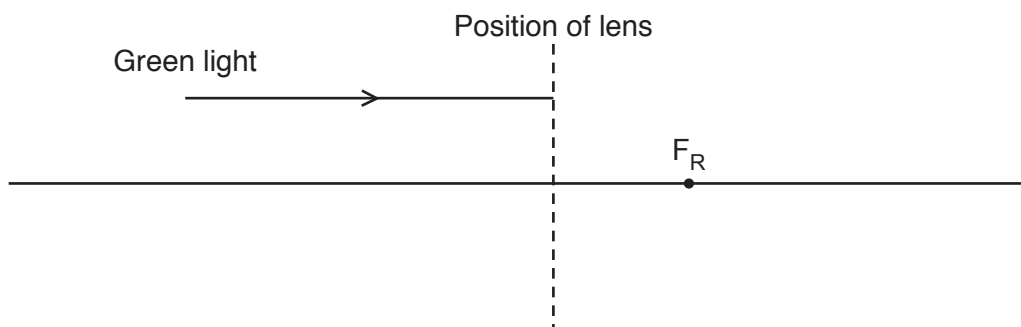

Fig. 18.5

[1]

(ii) Explain your answer to (e)(i).

.....
 [1]

(iii) Is the lens in Fig. 18.4 and 18.5 suitable for correcting long-sight or short-sight?

Tick (✓) **one** box.

Long-sight

Short-sight

Explain your answer.

.....
 [2]

19 (a) Nuclear **fusion** is a reaction that happens in stars. This equation for fusion is incomplete.

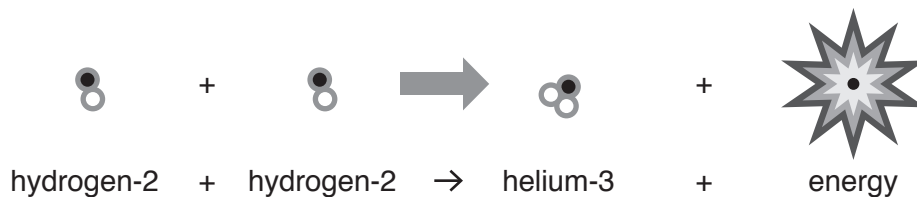

(i) What else is produced in this reaction?

.....
 [1]

(ii) Stars are formed from dust and gas.

What causes the dust and gas to undergo fusion?

.....
 [1]

(b) (i) Describe one **similarity** between nuclear fission and nuclear fusion.

.....
 [1]

(ii) Describe one **difference** between nuclear fission and nuclear fusion.

.....
 [1]

(c) Nuclear fission can be used as a power source to produce electricity.

Give one **advantage** and one **disadvantage** of using nuclear power to produce electricity.

advantage

disadvantage

[2]

20 Energy is transferred at high voltages in the national grid.

(a) This house is near to a transmission line.



Explain why radio waves may be produced by the transmission line.

.....
.....
..... [2]

(b) Explain why it is more efficient to transfer energy at high voltages.

.....
.....
..... [2]

(c) The transmission line has a power loss of 6.156 kW.

Its resistance is $15.39\ \Omega$.

Calculate the current in the transmission line.

Current = A [5]

21 (a) Fig. 21.1 is a speed-time graph for car P.

The driver of car P reacts to a traffic light at time = 0.00s, then presses the brakes at time = 0.50s.

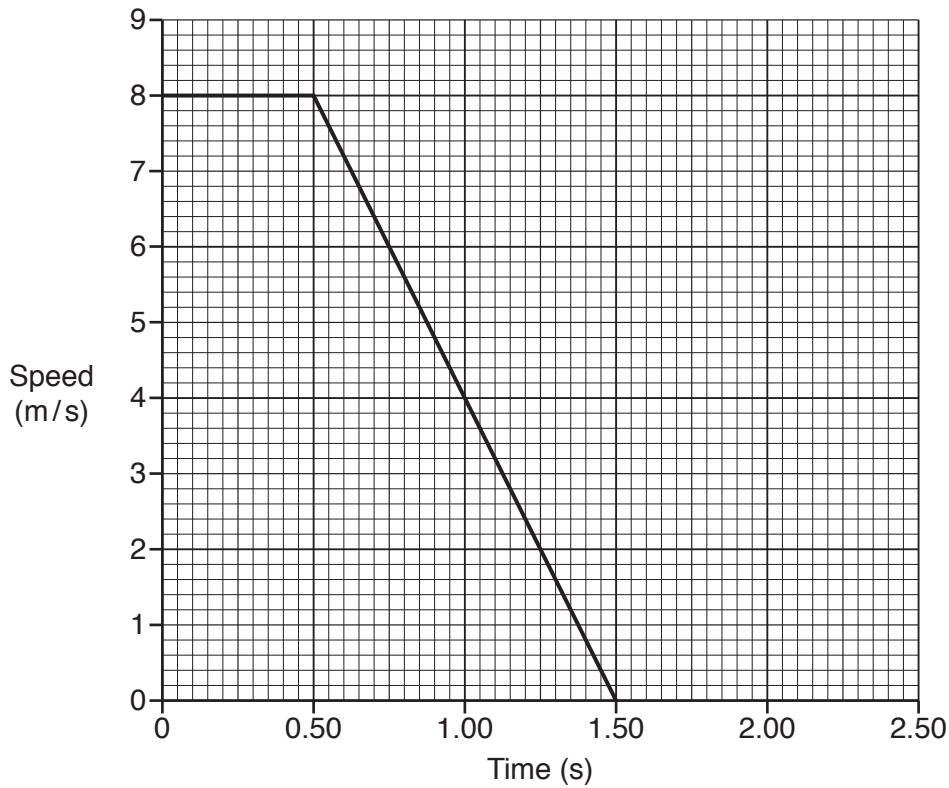

Fig. 21.1

(i) The braking distance is the same size as the thinking distance.

Explain how the graph in Fig. 21.1 shows this.

.....
 [1]

(ii) Add another line to the graph in Fig. 21.1 to show the journey of car Q.

- Car Q is travelling at 8 m/s.
- The driver of car Q reacts, then presses the brakes after 0.75s.
- Car Q decelerates at the same rate as car P.

[2]

(b) Driver **P** measures the reaction time of driver **Q** using a 30 cm ruler.

Driver **P** drops a 30 cm ruler vertically and driver **Q** catches it.

(i) Explain how the ruler can be used to estimate reaction time.

.....
.....
..... [1]

(ii) State **one** precaution they can use to get accurate results.

.....
.....
..... [1]

(c) In the brakes of a car there are brake pads and a brake disc, as shown in Fig. 21.2.

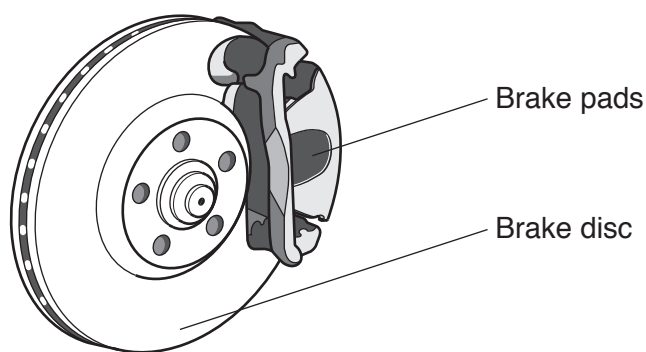

Fig. 21.2

When a car stops, energy transfers between stores.

The brake pads squeeze the brake disc and cause a friction force.

(i) Explain how braking stops the car.

Include ideas about **energy stores** in your answer.

.....

.....

..... [2]

(ii) High speed cars have ventilated brakes with air holes in the disc, as shown in Fig. 21.3.

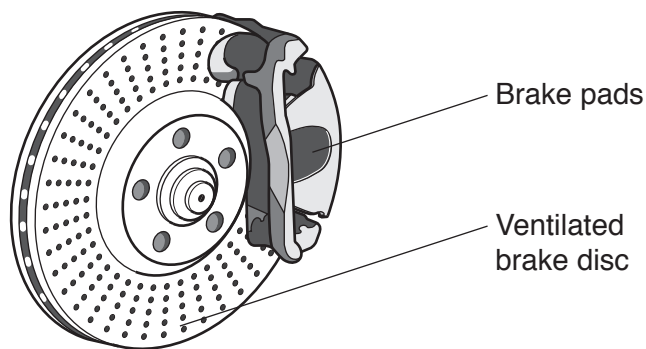

Fig. 21.3

The air holes allow more air to circulate around the disc.

Suggest how these brakes can reduce braking distances.

.....

..... [1]

22* The Earth contains a crust, mantle and core as shown in Fig. 22.1.

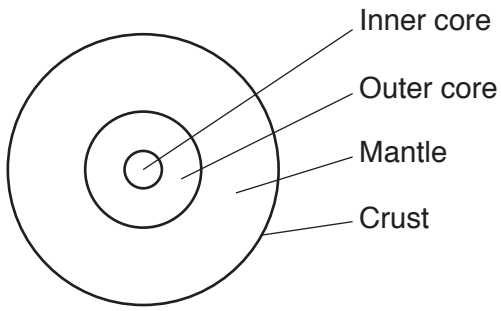

Fig. 22.1

Table 22.1 gives some data about seismic waves and the Earth.

	Density (g/cm ³)	P wave speed (km/s)	S wave speed (km/s)
Top of crust	2.2	5.55	3.25
Top of mantle	3.4	7.97	4.55
Top of outer core	9.9	8.10	-
Bottom of outer core	12.2	10.30	-

Table 22.1

Describe what information the data in Table 22.1 gives about the structure of the Earth.

In your answer you should explain any trends in the data in Table 22.1.

.....
.....
.....
.....
.....
.....
.....
.....
.....
.....
.....
.....
.....
.....
.....
.....
.....
.....
.....
.....
.....
.....
.....
.....
.....

[6]

21
BLANK PAGE

PLEASE DO NOT WRITE ON THIS PAGE

23 A teacher measures the activity of different radioactive isotopes.

Fig. 23.1 is a graph of her results for isotope A.

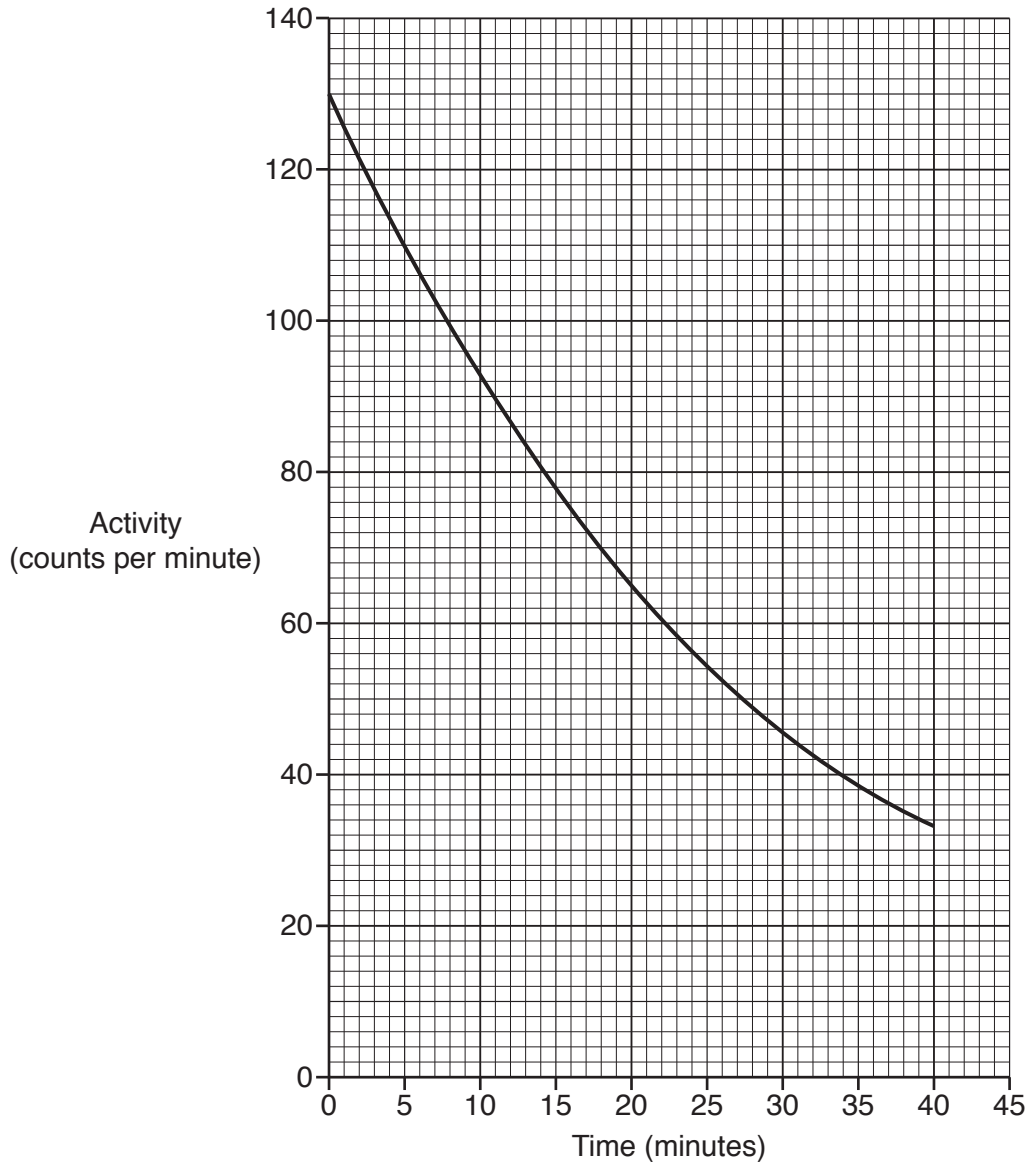

Fig. 23.1

(a) Use Fig. 23.1 to calculate the half-life of isotope A.

Show your working on the graph in Fig. 23.1.

Half-life = minutes [2]

(b) The teacher measures the activity of isotope **B**.

She starts taking activity measurements after 20 minutes.

Table 23.1 shows her results for isotope **B**.

Time (minutes)	Activity (counts per minute)
0	
10	
20	84
30	64
40	52
50	40
60	32
70	25
80	20
90	16

Table 23.1

Predict the activity of isotope **B** at 0 minutes.

Use the information in **Table 23.1** to help you.

Activity = counts per minute [2]

(c) The teacher measures the activity of isotope C.

Fig. 23.2 is a graph which shows how activity varies with time for isotope C.

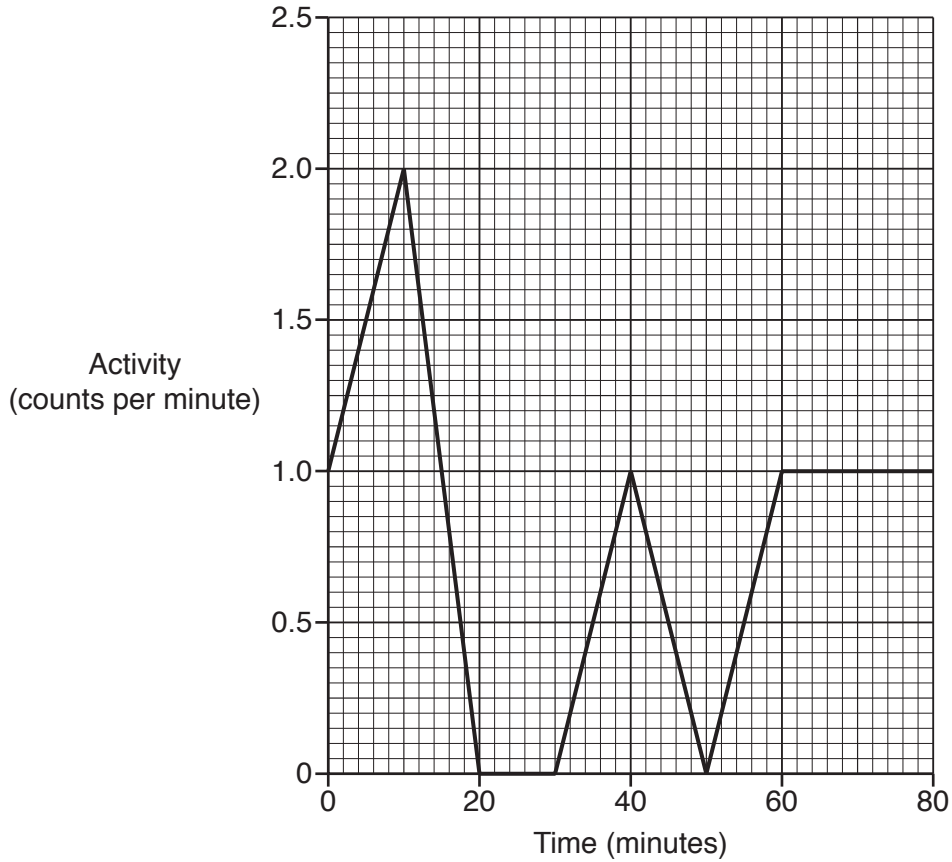

Fig. 23.2

A student makes two conclusions from the graph in Fig. 23.2:

Conclusion 1: I think the results are very inaccurate.

The isotope stops being radioactive and then gets more radioactive again.

Conclusion 2: I do **not** think the isotope has a half-life.

Is the student correct?

Evaluate **each** conclusion and explain your answer.

Conclusion 1

.....

.....

Conclusion 2

.....

..... [2]

25
BLANK PAGE

PLEASE DO NOT WRITE ON THIS PAGE

24 (a) Some students try to measure the speed of sound, as shown in **Fig. 24.1**.

One student makes a loud sound by clapping her hands.

The sound of the clap reflects from the gym wall causing an echo.

Another student measures the time between hearing the clap and hearing the echo.

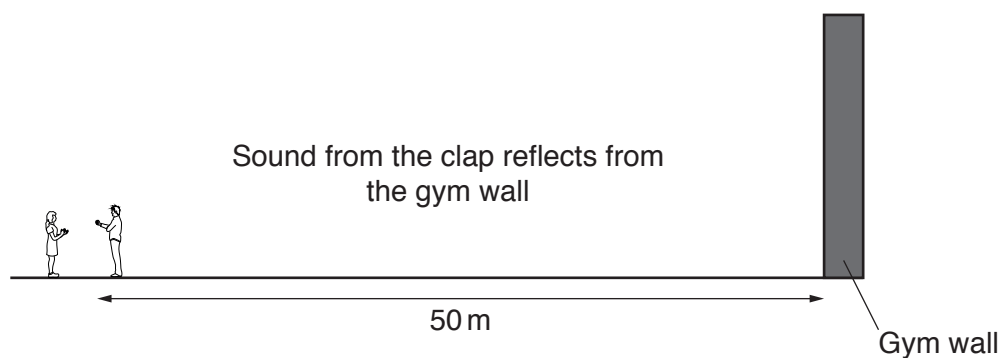

Fig. 24.1

They repeat the experiment three times and record their results in the table below.

Distance to wall (m)	Time 1 (s)	Time 2 (s)	Time 3 (s)	Mean time (s)
50	0.28	0.32	0.54	

(i) The student did not pay attention when recording **time 3**.

Calculate the **mean** time taken for the sound of the clap to return, using suitable values from the table.

Mean time taken = s [1]

(ii) Calculate the speed of sound for the clap.

Use your answer to (a)(i) and the equation: distance travelled = speed × time

Give your answer to 3 significant figures.

Speed of sound = m/s [4]

(iii) Describe **two** ways to improve and develop their method.

1

.....

2

.....

[2]

(b) Ultrasound wave pulses are used by vets to scan inner tissues inside animals.

The ultrasound pulses partially reflect from different layers of tissue. These reflected wave pulses (echoes) are collected by the detector as shown in Fig. 24.2.

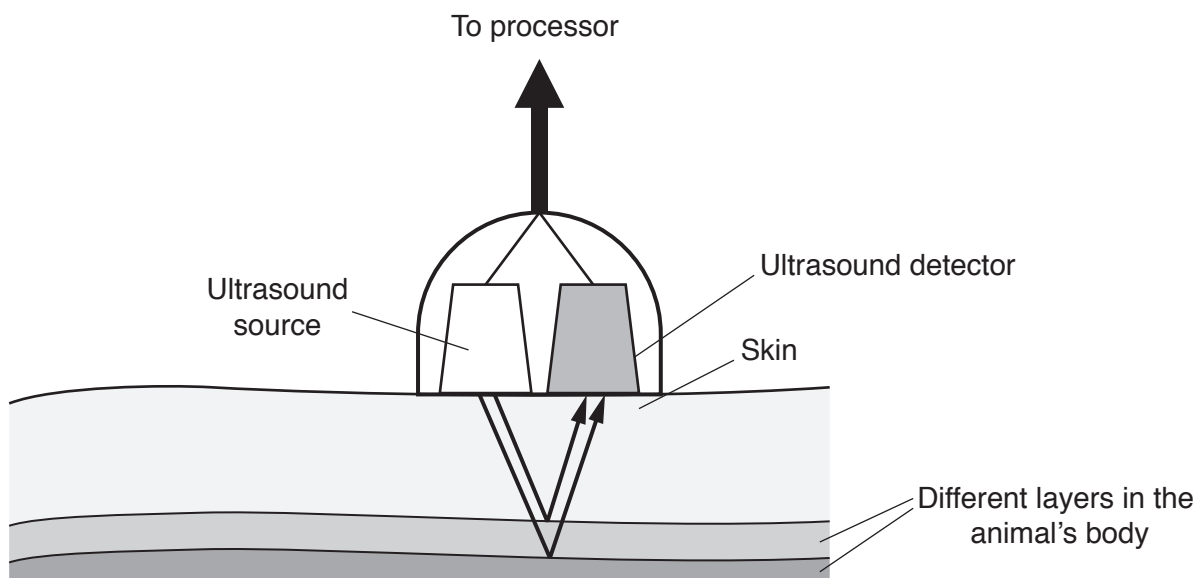

Fig. 24.2

In a scan using ultrasound pulses, three layers of tissue are detected, with each layer having a different thickness.

Describe and explain how the results from the detector can show:

- that there are three layers
- that each layer has a different thickness.

.....

.....

.....

.....

.....

.....

.....

.....

.....

[3]

END OF QUESTION PAPER

ADDITIONAL ANSWER SPACE

If additional space is required, you should use the following lined page(s). The question number(s) must be clearly shown in the margin(s).

A large area of lined paper for writing. It consists of a vertical solid line on the left side, creating a margin. To the right of this line, there are numerous horizontal dotted lines spaced evenly down the page, providing a guide for writing.

Blank lined writing area with horizontal dotted lines and a vertical solid line on the left side.

A large rectangular area with a solid vertical line on the left side and horizontal dotted lines extending across the page, providing a space for writing answers.



Copyright Information

OCR is committed to seeking permission to reproduce all third-party content that it uses in its assessment materials. OCR has attempted to identify and contact all copyright holders whose work is used in this paper. To avoid the issue of disclosure of answer-related information to candidates, all copyright acknowledgements are reproduced in the OCR Copyright Acknowledgements Booklet. This is produced for each series of examinations and is freely available to download from our public website (www.ocr.org.uk) after the live examination series. If OCR has unwittingly failed to correctly acknowledge or clear any third-party content in this assessment material, OCR will be happy to correct its mistake at the earliest possible opportunity.

For queries or further information please contact The OCR Copyright Team, The Triangle Building, Shaftesbury Road, Cambridge CB2 8EA.

OCR is part of the Cambridge Assessment Group; Cambridge Assessment is the brand name of University of Cambridge Local Examinations Syndicate (UCLES), which is itself a department of the University of Cambridge.