

| | | | | | | | | | | |
|---------------------|--|--|--|--|--|------------------|--|--|--|--|
| Centre Number | | | | | | Candidate Number | | | | |
| Surname | | | | | | | | | | |
| Other Names | | | | | | | | | | |
| Candidate Signature | | | | | | | | | | |

| | |
|---------------------|------|
| For Examiner's Use | |
| Examiner's Initials | |
| Question | Mark |
| 1 | |
| 2 | |
| 3 | |
| 4 | |
| 5 | |
| 6 | |
| 7 | |
| TOTAL | |



General Certificate of Education
Advanced Subsidiary Examination
June 2013

Physics A

PHYA1

Unit 1 Particles, Quantum Phenomena and Electricity

Monday 20 May 2013 1.30 pm to 2.45 pm

For this paper you must have:

- a pencil and a ruler
- a calculator
- a Data and Formulae Booklet (enclosed).

Time allowed

- 1 hour 15 minutes

Instructions

- Use black ink or black ball-point pen.
- Fill in the boxes at the top of this page.
- Answer **all** questions.
- You must answer the questions in the spaces provided. Do not write outside the box around each page or on blank pages.
- Do all rough work in this book. Cross through any work you do not want to be marked.
- Show all your working.

Information

- The marks for questions are shown in brackets.
- The maximum mark for this paper is 70.
- You are expected to use a calculator where appropriate.
- A *Data and Formulae Booklet* is provided as a loose insert.
- You will be marked on your ability to:
 - use good English
 - organise information clearly
 - use specialist vocabulary where appropriate.



J U N 1 3 P H Y A 1 0 1

Answer **all** questions in the spaces provided.

1 An atom of calcium, ${}_{20}^{48}\text{Ca}$, is ionised by removing two electrons.

1 (i) State the number of protons, neutrons and electrons in the ion formed.

protons

neutrons

electrons

(3 marks)

1 (ii) Calculate the charge of the ion.

charge C
(1 mark)

1 (iii) Calculate the specific charge of the ion.

specific charge C kg^{-1}
(2 marks)

| |
|---|
| 6 |
|---|



2 A positron is emitted from a nucleus when a proton changes to a neutron in the nucleus. The Feynman diagram for the quark interaction is shown in **Figure 1**.

Figure 1

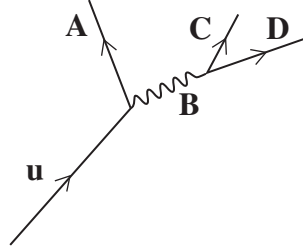

2 (a) Identify the particles labelled **A**, **B**, **C** and **D** in the diagram.

- A
- B
- C
- D

(3 marks)

2 (b) (i) State the interaction responsible for this process.

.....
(1 mark)

2 (b) (ii) State which letter in **Figure 1** represents an exchange particle.

.....
(1 mark)

2 (b) (iii) State **one** difference between this exchange particle and a photon.

.....
(1 mark)

Question 2 continues on the next page

Turn over ►



2 (c) Energy and momentum have to be conserved in this process. State **two** other quantities that need to be conserved and show that they are conserved in the process.

quantity 1

.....

.....

quantity 2

.....

.....

(4 marks)

| |
|----|
| |
| 10 |



3 (a)

Hadrons and leptons are two groups of particles.

Write an account of how particles are placed into one or other of these two groups.

Your account should include the following:

- how the type of interaction is used to classify the particles
- examples of each type of particle
- details of any similarities between the two groups
- details of how **one** group may be further sub-divided.

The quality of your written communication will be assessed in your answer.

.....

.....

.....

.....

.....

.....

.....

.....

.....

.....

.....

.....

.....

.....

.....

.....

.....

.....

.....

.....

.....

.....

.....

.....

.....

.....

(6 marks)

Turn over ►



3 (b) Every type of particle has a corresponding antiparticle.

3 (b) (i) Give **one** example of a particle and its corresponding antiparticle.

particle

antiparticle

(1 mark)

3 (b) (ii) State **one** difference between this particle and its antiparticle.

.....

.....

(1 mark)

| |
|---|
| 8 |
|---|



4 When ultraviolet light of frequency 3.0×10^{15} Hz is incident on the surface of a metal, electrons of maximum kinetic energy 1.7×10^{-18} J are emitted.

4 (a) Explain why the emitted electrons have a range of kinetic energies up to a maximum value.

.....
.....
.....
.....
.....
.....

(3 marks)

4 (b) (i) Show that the work function of the metal is 1.8 eV.

(3 marks)

4 (b) (ii) Calculate the threshold frequency of the metal. Give your answer to an appropriate number of significant figures.

threshold frequency Hz
(3 marks)

Turn over ►



4 (c) (i) State and explain the effect on the emitted electrons of decreasing the frequency of the incident radiation whilst keeping the intensity constant.

.....
.....
.....
.....

(2 marks)

4 (c) (ii) State and explain the effect on the emitted electrons of doubling the intensity of the incident radiation whilst keeping the frequency constant.

.....
.....
.....
.....

(2 marks)

| |
|-----------|
| |
| 13 |



5 **Figure 2** shows how a sinusoidal alternating voltage varies with time when connected across a resistor, R.

Figure 2

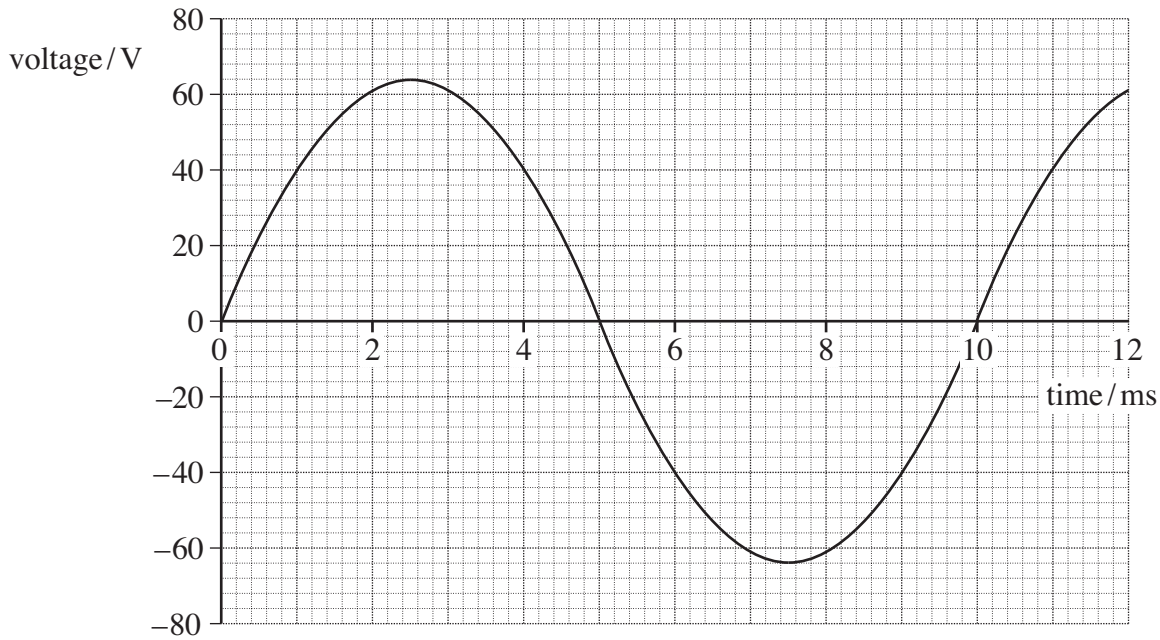

5 (a) (i) State the peak-to-peak voltage.

peak-to-peak voltage V
(1 mark)

5 (a) (ii) State the peak voltage.

peak voltage V
(1 mark)

5 (a) (iii) Calculate the root mean square (rms) value of the alternating voltage.

rms voltage V
(2 marks)

Question 5 continues on the next page

Turn over ►



5 (a) (iv) Calculate the frequency of the alternating voltage. State an appropriate unit.

frequency unit
(3 marks)

5 (b) On **Figure 2** draw a line to show the dc voltage that gives the same rate of energy dissipation in R as produced by the alternating waveform.
(2 marks)

5 (c) An oscilloscope has a screen of eight vertical and ten horizontal divisions. Describe how you would use the oscilloscope to display the alternating waveform in **Figure 2** so that two complete cycles are visible.

.....
.....
.....
.....
.....
.....
.....
.....
.....
.....
.....

(3 marks)

| |
|----|
| 12 |
|----|



- 6** The circuit in **Figure 3** shows a battery of electromotive force (emf) 12 V and internal resistance 1.5Ω connected to a 2.0Ω resistor in parallel with an unknown resistor, R. The battery supplies a current of 4.2 A.

Figure 3

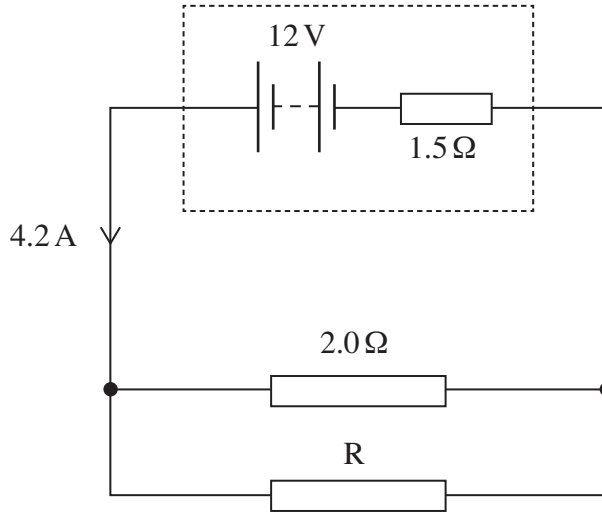

- 6 (a) (i)** Show that the potential difference (pd) across the internal resistance is 6.3 V.

(1 mark)

- 6 (a) (ii)** Calculate the pd across the 2.0Ω resistor.

pd V
(1 mark)

- 6 (a) (iii)** Calculate the current in the 2.0Ω resistor.

current A
(1 mark)

- 6 (a) (iv)** Determine the current in R.

current A
(1 mark)

Turn over ►



6 (a) (v) Calculate the resistance of R.

R Ω
(1 mark)

6 (a) (vi) Calculate the total resistance of the circuit.

circuit resistance Ω
(2 marks)

6 (b) The battery converts chemical energy into electrical energy that is then dissipated in the internal resistance and the two external resistors.

6 (b) (i) Using appropriate data values that you have calculated, complete the following table by calculating the rate of energy dissipation in each resistor.

| resistor | rate of energy dissipation/W |
|---------------------|------------------------------|
| internal resistance | |
| 2.0 Ω | |
| R | |

(3 marks)

6 (b) (ii) Hence show that energy is conserved in the circuit.

.....
.....

(2 marks)



7 **Figure 4** shows a 6.0 V battery of negligible internal resistance connected in series to a light dependent resistor (LDR), a variable resistor and a fixed resistor, R.

Figure 4

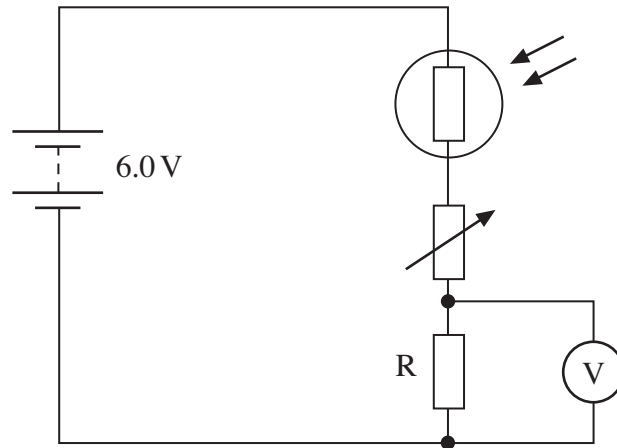

7 (a) For a particular light intensity the resistance of the LDR is $50\text{ k}\Omega$. The resistance of R is $5.0\text{ k}\Omega$ and the variable resistor is set to a value of $35\text{ k}\Omega$.

7 (a) (i) Calculate the current in the circuit.

current A
(2 marks)

7 (a) (ii) Calculate the reading on the voltmeter.

voltmeter reading V
(2 marks)

7 (b) State and explain what happens to the reading on the voltmeter if the intensity of the light incident on the LDR increases.

.....

 (2 marks)

Turn over ►



- 7 (c) For a certain application at a particular light intensity the pd across R needs to be 0.75 V. The resistance of the LDR at this intensity is 5.0 k Ω .

Calculate the required resistance of the variable resistor in this situation.

resistance Ω
(3 marks)

| |
|---|
| 9 |
|---|

END OF QUESTIONS



There are no questions printed on this page

**DO NOT WRITE ON THIS PAGE
ANSWER IN THE SPACES PROVIDED**



There are no questions printed on this page

**DO NOT WRITE ON THIS PAGE
ANSWER IN THE SPACES PROVIDED**

