

Centre Number						Candidate Number				
Surname										
Other Names										
Candidate Signature										

For Examiner's Use	
Examiner's Initials	
Question	Mark
1	
2	
3	
4	
5	
6	
7	
8	
TOTAL	



General Certificate of Education
Advanced Level Examination
June 2014

Physics (B): Physics in Context

PHYB4

Unit 4 Physics Inside and Out

Module 1 Experiences Out of this World

Module 2 What Goes Around Comes Around

Module 3 Imaging the Invisible

Wednesday 11 June 2014 1.30 pm to 3.15 pm

For this paper you must have:

- a pencil and a ruler
- a calculator
- a Data and Formulae Booklet (enclosed).

Time allowed

- 1 hour 45 minutes

Instructions

- Use black ink or black ball-point pen. Use pencil only for drawing.
- Fill in the boxes at the top of this page.
- Answer **all** questions.
- You must answer the questions in the spaces provided. Do not write outside the box around each page or on blank pages.
- Do all rough work in this book. Cross through any work you do not want to be marked.
- Show all your working.

Information

- The marks for questions are shown in brackets.
- The maximum mark for this paper is 100.
- You are expected to use a calculator where appropriate.
- A *Data and Formulae Booklet* is provided as a loose insert.
- You will be marked on your ability to:
 - use good English
 - organise information clearly
 - use specialist vocabulary where appropriate.



Answer **all** questions in the spaces provided.

1 Theme park rides are thrilling because large and varying accelerations and forces give the riders the perception of danger.

1 (a) In Kamikaze rides, illustrated in **Figure 1**, passengers are seated in a pair of gondolas that move in vertical circles in opposite directions. Each gondola system includes the gondola, a counterweight and the arm on which it is mounted. The distance between the centre of the axle and the centre of mass of a gondola is 6.8 m.

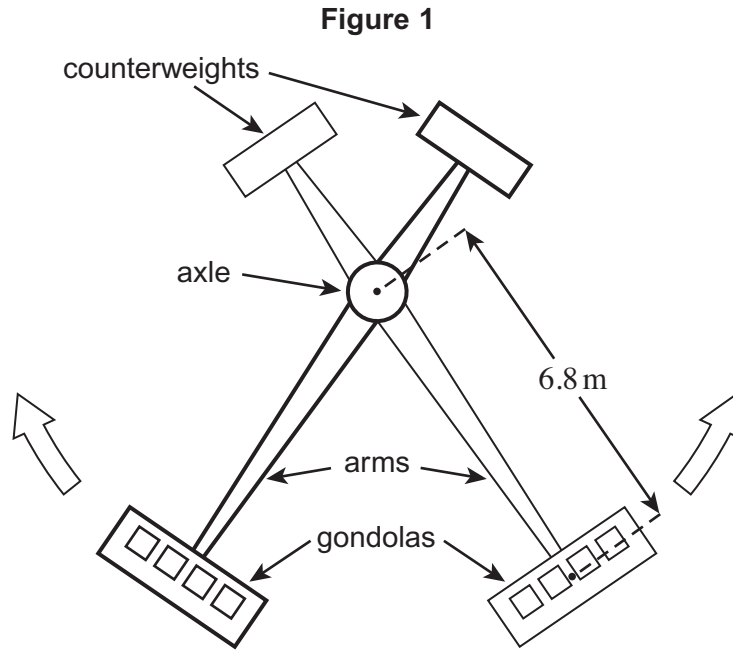

1 (a) (i) Explain the purpose of the counterweights.

[2 marks]

.....

.....

.....

.....

1 (a) (ii) Explain how the counterweights can be effective, even though the arms on which they are mounted are shorter than the arms carrying the gondolas.

[2 marks]

.....

.....

.....

.....



1 (a) (iii) The ride starts from rest with both gondolas at the bottom. A motor is used to accelerate each gondola system uniformly from rest to an angular velocity of 1.4 rad s^{-1} in 2.6 s. Each gondola system has a moment of inertia of $1.9 \times 10^5 \text{ kg m}^2$. Calculate the torque applied by the motor to each gondola system during this acceleration.

[3 marks]

torque N m

1 (a) (iv) The gondolas now execute circles at a constant angular velocity of 1.4 rad s^{-1} . Calculate the centripetal force exerted on a passenger of mass 86 kg during this part of the ride.

[2 marks]

centripetal force N

1 (a) (v) Calculate the normal reaction exerted on the passenger by his or her seat when the gondola is at the top of its circular path.

[2 marks]

normal reaction N

1 (a) (vi) Describe how the magnitude of this normal reaction varies during one complete rotation of the gondola.

[2 marks]

.....
.....
.....
.....

Turn over ►



- 1 (b) **Figure 2** shows another ride called a Waltzer. It has cars that are mounted on an undulating bed. The bed rotates over the top of a fixed base so that the cars travel in a circular path and move up and down. The cars also rotate about individual axes that are normal to the undulating bed.

Figure 2

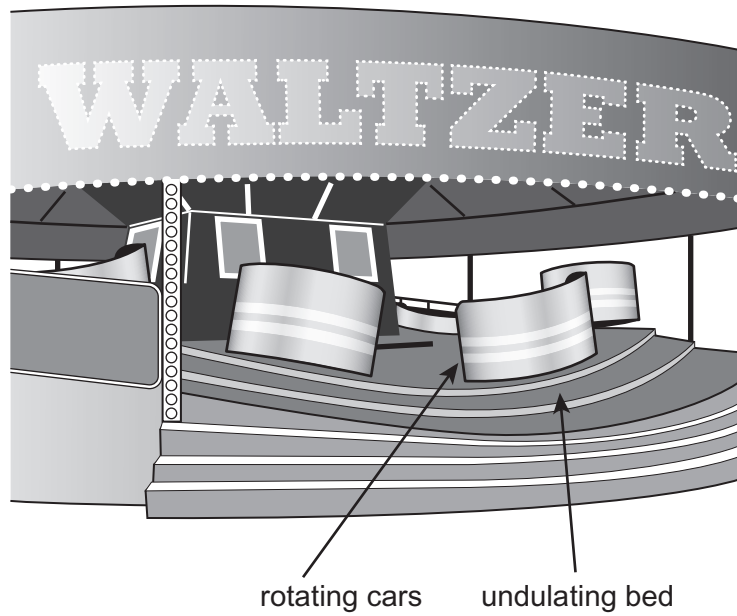

- 1 (b) (i) A Waltzer car, with its passengers, has a moment of inertia about its own axis of 270 kg m^2 . At one instant it rotates with an angular velocity of 5.3 rad s^{-1} . Calculate the kinetic energy of the car and its passengers, due to this rotation.

[2 marks]

kinetic energy J

- 1 (b) (ii) Explain why the forces experienced by a rider on a Waltzer vary unpredictably.

[3 marks]

.....

.....

.....

.....

.....

.....

.....



1 (b) (iii) The torques accelerating a Waltzer car may be considered to be independent of the masses of the passengers.
Explain why, for safety reasons, passengers are required to be of a minimum size before being allowed to use the ride.

[2 marks]

.....

.....

.....

.....

20

Turn over for the next question

Turn over ►



2 This question is about the space shuttle. The space shuttle orbiter had a mass in orbit of 1.1×10^5 kg. It was often put into low Earth orbit at a height of 330 km above the Earth's surface, giving it an orbital radius of 6710 km.

2 (a) (i) Show that the shuttle orbiter's speed in orbit was approximately 7700 m s^{-1} .

mass of the Earth = 6.0×10^{24} kg

[3 marks]

2 (a) (ii) Calculate the kinetic energy of the shuttle orbiter when it is in this orbit.

[1 mark]

kinetic energy J

2 (a) (iii) Calculate the minimum value of the **total** energy required to lift the shuttle orbiter into this low Earth orbit. Assume that it had no kinetic energy before the launch.

[5 marks]

total energy J



2 (a) (iv) The launch required more energy than this, partly due to the work done against air resistance.
 State **two** other reasons why, in practice, more energy was required.

[2 marks]

reason 1

.....

reason 2

.....

2 (b) **Figure 3** is a graph showing the variation in gravitational potential between the position of the Earth's orbit, **E**, around the Sun, and a similar orbit, **P**, around the next nearest star, Proxima Centauri.

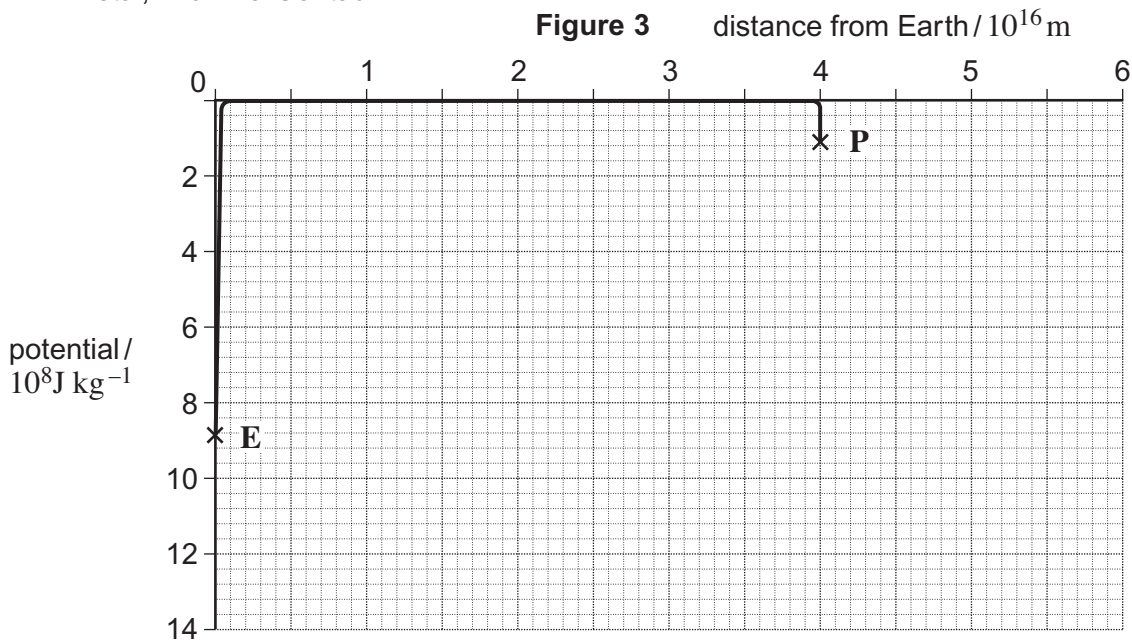

2 (b) (i) Use data from the graph to determine how much work would be done to move the shuttle from **E** to a point midway between **E** and **P**.

[2 marks]

work done J

2 (b) (ii) Explain why the shuttle would need to use additional fuel in order to establish itself in the orbit, **P**, around Proxima Centauri.

[2 marks]

.....

.....

.....

.....



- 3 (a) Geophysicists use a Hall probe to detect anomalous variations in the magnetic flux density above the ground. A Hall probe is usually a small piece of a semiconductor material that is placed in the magnetic field, labelled **B** in **Figure 4**. The power supply produces a current through the Hall probe. The direction of electron movement is from **X** to **Y**. This is opposite to the direction of the conventional current. When the charge flows, a potential difference (pd) is produced between the **left** and **right** sides of the semiconductor. The magnitude of the pd depends on the magnetic flux density.

Figure 4

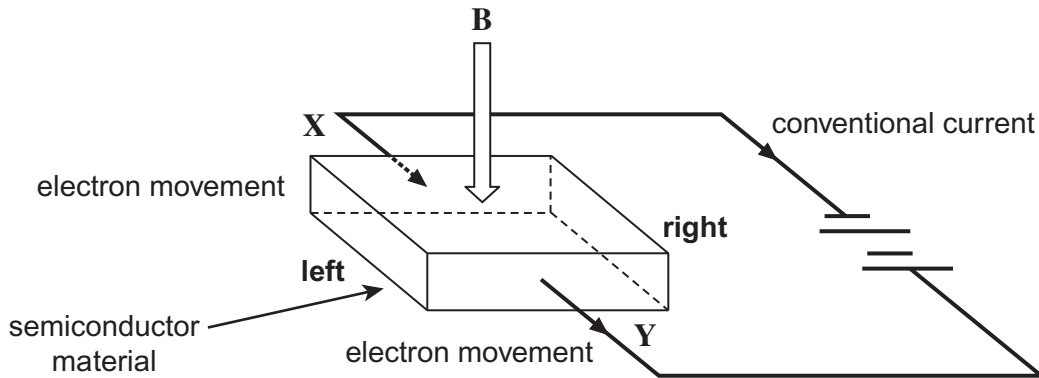

- 3 (a) (i) The unit of magnetic flux is the tesla. Explain how the force on a current-carrying conductor in a magnetic field is used to define a flux density of 1 T.

[2 marks]

.....

.....

.....

.....

- 3 (a) (ii) Explain how the effect of the magnetic field on the electron path in the semiconductor produces the pd between its **left** and **right** sides.

[3 marks]

.....

.....

.....

.....

.....



3 (a) (iii) Suggest how measurements of the pd produced in the semiconductor, carried out over a wide area, can locate the positions of some types of object buried beneath ground level in that area.

[2 marks]

.....

.....

.....

.....

Question 3 continues on the next page

Turn over ►



- 3 (b) Describe how buried metallic objects can also be located using a metal detector. You should explain the principles involved in the operation of the metal detector. You may draw a diagram in the space provided to help you.

The quality of your written communication will be assessed in your answer.

[6 marks]

.....

.....

.....

.....

.....

.....

.....

.....

.....

.....

.....

.....

.....

.....

.....

.....

.....

.....

.....

.....

13



Turn over for the next question

**DO NOT WRITE ON THIS PAGE
ANSWER IN THE SPACES PROVIDED**

Turn over ►



4 (a) A space shuttle rocket motor has a combustion chamber of volume 12 m^3 . When tested prior to use, the temperature in the chamber was found to be $3200\text{ }^\circ\text{C}$ and the pressure was 20.6 MPa .

4 (a) (i) Calculate the number of moles of gas in the combustion chamber during the test. **[3 marks]**

number of moles

4 (a) (ii) Describe how the first law of thermodynamics applies to the gas as it leaves the rocket motor. **[4 marks]**

.....

.....

.....

.....

.....

.....

.....

.....

.....

4 (a) (iii) For optimum performance, the pressure of the gas leaving the rocket motor should be equal to atmospheric pressure. Explain why the efficiency of the motor would be reduced if the pressure of the gas leaving the rocket were greater than atmospheric pressure. **[1 mark]**

.....

.....

.....



4 (b) A single-stage rocket in gravity-free and drag-free space has an effective gas exhaust velocity of 3800 m s^{-1} . The rocket could achieve a maximum speed of 6400 m s^{-1} by using all of its fuel.
Calculate the percentage of the original mass of the rocket that is fuel.

[4 marks]

percentage of the original mass of the rocket

4 (c) Ion drives provide thrusts of up to 5 N by using electric fields to accelerate positive ions to speeds of up to 30 km s^{-1} . Their energy supply usually comes from photovoltaic cells.

4 (c) (i) Suggest an advantage of an ion drive compared with conventional rocket motors.

[1 mark]

.....

4 (c) (ii) Suggest a disadvantage of an ion drive compared with conventional rocket motors.

[1 mark]

.....

4 (c) (iii) Suggest a use for an ion drive that takes advantage of its properties.

[1 mark]

.....

15

Turn over ►



5 X-rays are produced when high-energy electrons strike the metal target in an X-ray tube. The spectrum of the X-rays produced in one tube is shown in **Figure 5**.

Figure 5

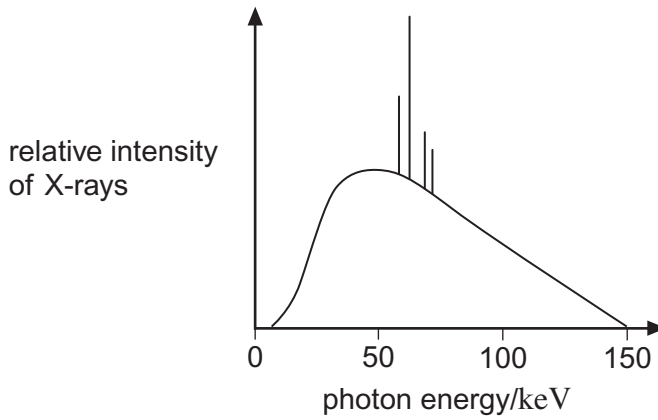

5 (a) (i) Describe how the continuous part of the X-ray spectrum is produced.

[3 marks]

.....

.....

.....

.....

.....

.....

.....

5 (a) (ii) Using data from **Figure 5**, calculate the minimum wavelength of X-rays produced by the tube.

[3 marks]

minimum wavelength m



5 (b) The attenuation coefficient for the most common X-rays from the tube when travelling through bone is 150 m^{-1} .
 X-rays of this type are incident on bone.
 Calculate the percentage of the X-rays that remain when the beam has passed through a bone of thickness 3.5 cm.

[3 marks]

percentage of the X-rays that remain

5 (c) **Contrast mediums** are often used to improve image quality for X-rays.
 State briefly how contrast mediums help to improve the image.

[2 marks]

.....

.....

.....

.....

11

Turn over for the next question

Turn over ►



6 In an MRI scanner, a **gradient field** is applied to the patient and radio frequency, rf, waves are passed through the body. The rf waves cause protons in the body to precess.

6 (a) (i) State what is meant by a gradient field.

[2 marks]

.....
.....
.....
.....

6 (a) (ii) State what happens to protons in the body when a gradient field is applied at the same time as the rf waves and explain how the gradient field helps to image a single thin section of the patient.

[3 marks]

.....
.....
.....
.....
.....
.....

6 (a) (iii) Describe how the precessional energy of the protons in a part of the patient's body can be used to image that part of the body.

[3 marks]

.....
.....
.....
.....
.....
.....



6 (a) (iv) Describe how a complete body image is produced by the MRI scanner.

[2 marks]

.....

.....

.....

.....

6 (b) Another device that may be used to produce a three-dimensional image of a patient is a computerised tomography (CT) scanner. Describe **one** advantage and **one** disadvantage of an MRI scanner compared with a CT scanner.

[2 marks]

Advantage of MRI scanner

.....

Disadvantage of MRI scanner

.....

.....

12

Turn over for the next question

Turn over ►



- 7 **Figure 6** illustrates a geophone being used to detect sound waves generated by a small surface explosion on a geological site. An explosion is detonated at ground level 2.6 m above a buried limestone wall. The most direct path, **A**, for the sound is along the soil surface. Another sound wave, following path **B**, meets the limestone at the critical angle. This wave is refracted into the limestone and travels along the top edge of the wall, within the limestone.

speed of sound in soil = 1800 m s^{-1}
 speed of sound in limestone = 3000 m s^{-1}

Figure 6

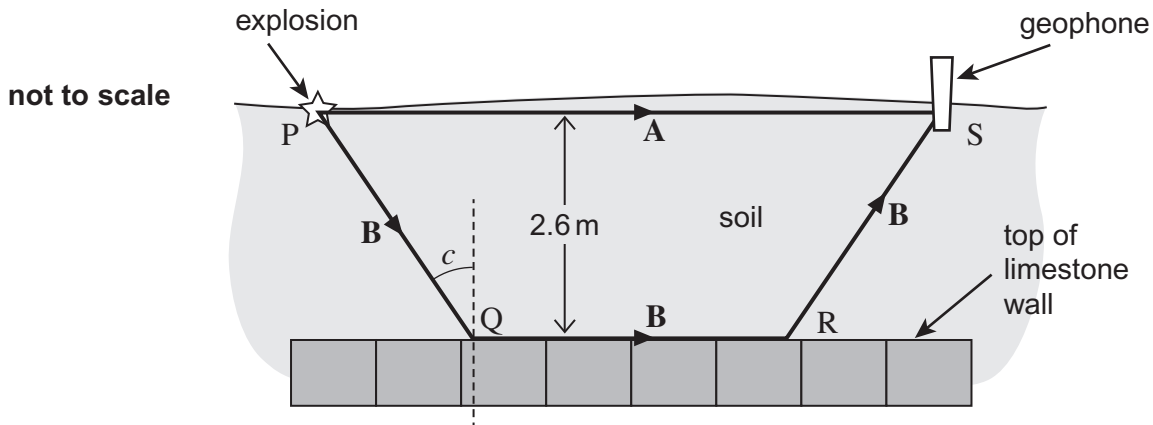

- 7 (a) Show that the critical angle, c , for sound travelling from soil to limestone is approximately 37° . [3 marks]

- 7 (b) The length of path **A** is 9.8 m.
 Calculate the time taken for the sound to reach the geophone along path **A**. [1 mark]

time taken s



- 7 (c)** Determine the lengths PQ, QR and RS and use these to find the time taken for the sound to reach the geophone along path **B**.

[5 marks]

time taken s

9

Turn over for the next question

Turn over ►



8 Gravimeters are used to make accurate measurements of the acceleration due to gravity. This enables geophysicists to detect the presence of dense objects beneath the surface of the ground. In one type of gravimeter, the acceleration of a falling glass prism is determined from measurements of the distance it falls from rest and the time taken for it to fall.

8 (a) The distance moved by the prism can be determined to a precision of $\pm 0.02\%$. The time taken for the prism to fall from rest is $90.00 \text{ ms} \pm 0.01 \text{ ms}$. Show that percentage uncertainty in the measurement of g is approximately 0.04% . **[3 marks]**

8 (b) Determine the smallest change in gravitational field strength that can be detected by the gravimeter. Give your answer in gal. **[2 marks]**

change in gravitational field strength gal

5

END OF QUESTIONS

