

Friday 16 June 2017 – Morning

**GCSE TWENTY FIRST CENTURY SCIENCE
PHYSICS A/ADDITIONAL SCIENCE A**

A182/01 Modules P4 P5 P6 (Foundation Tier)

Candidates answer on the Question Paper.
A calculator may be used for this paper.

OCR supplied materials:

None

Other materials required:

- Pencil
- Ruler (cm/mm)

Duration: 1 hour

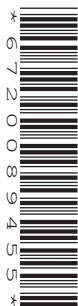

Candidate forename		Candidate surname	
-----------------------	--	----------------------	--

Centre number						Candidate number				
---------------	--	--	--	--	--	------------------	--	--	--	--

INSTRUCTIONS TO CANDIDATES

- Write your name, centre number and candidate number in the boxes above. Please write clearly and in capital letters.
- Use black ink. HB pencil may be used for graphs and diagrams only.
- Answer **all** the questions.
- Read each question carefully. Make sure you know what you have to do before starting your answer.
- Write your answer to each question in the space provided. If additional space is required, you should use the lined page(s) at the end of this booklet. The question number(s) must be clearly shown.
- Do **not** write in the barcodes.

INFORMATION FOR CANDIDATES

- The quality of written communication is assessed in questions marked with a pencil (✎).
- A list of useful relationships is printed on page 2.
- The number of marks is given in brackets [] at the end of each question or part question.
- The total number of marks for this paper is **60**.
- This document consists of **20** pages. Any blank pages are indicated.

TWENTY FIRST CENTURY SCIENCE DATA SHEET

Useful Relationships

The Earth in the Universe

$$\text{distance} = \text{wave speed} \times \text{time}$$

$$\text{wave speed} = \text{frequency} \times \text{wavelength}$$

Sustainable Energy

$$\text{energy transferred} = \text{power} \times \text{time}$$

$$\text{power} = \text{voltage} \times \text{current}$$

$$\text{efficiency} = \frac{\text{energy usefully transferred}}{\text{total energy supplied}} \times 100\%$$

Explaining Motion

$$\text{speed} = \frac{\text{distance travelled}}{\text{time taken}}$$

$$\text{acceleration} = \frac{\text{change in velocity}}{\text{time taken}}$$

$$\text{momentum} = \text{mass} \times \text{velocity}$$

$$\text{change of momentum} = \text{resultant force} \times \text{time for which it acts}$$

$$\text{work done by a force} = \text{force} \times \text{distance moved in the direction of the force}$$

$$\text{amount of energy transferred} = \text{work done}$$

$$\text{change in gravitational potential energy} = \text{weight} \times \text{vertical height difference}$$

$$\text{kinetic energy} = \frac{1}{2} \times \text{mass} \times [\text{velocity}]^2$$

Electric Circuits

$$\text{power} = \text{voltage} \times \text{current}$$

$$\text{resistance} = \frac{\text{voltage}}{\text{current}}$$

$$\frac{\text{voltage across primary coil}}{\text{voltage across secondary coil}} = \frac{\text{number of turns in primary coil}}{\text{number of turns in secondary coil}}$$

Radioactive Materials

$$\text{energy} = \text{mass} \times [\text{speed of light in a vacuum}]^2$$

Answer **all** the questions

- 1 For each of the following situations say whether there are **no forces** acting on the object, or there is a **resultant force**, or there are forces acting which are **balanced**.

Put a tick (✓) in the one correct box for each situation.

Situation	No forces	Resultant force	Balanced forces
a ball accelerating as it falls vertically			
a person parachuting falling vertically at constant speed			
a book resting on a table			
a car moving along a straight road without accelerating			

[4]

[Total: 4]

2 Grace is playing golf. She swings her golf club so that it hits a stationary ball.

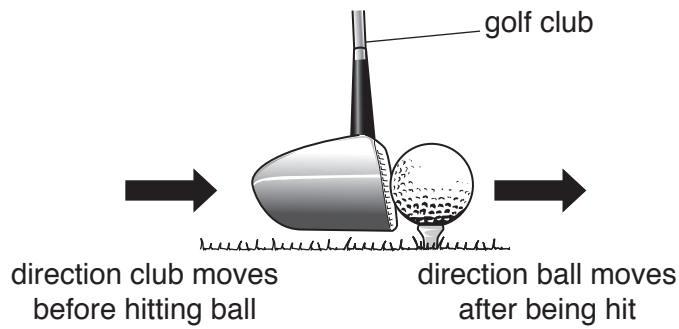

(a) (i) Why is the kinetic energy of the ball zero **before** it is hit?

..... [1]

(ii) The ball has mass 0.050 kg and velocity 40 m/s after it has been hit.

Calculate the kinetic energy of the ball **after** it has been hit.

Show your working.

kinetic energy = J [2]

(iii) Grace hears the club hit the ball.

How does the amount of kinetic energy gained by the ball compare with the kinetic energy of the club just before it hits the ball?

Put a (ring) around the correct answer.

less than **the same** **more than**

Justify your choice.

.....
 [2]

(b) (i) Grace calculates that the momentum of the ball changes by 2.0 kg m/s.

Explain how she got this value.

.....
..... [2]

(ii) The force **on the ball** due to the club is 4000 N.

How large is the force **on the club**?

Put a **ring** around the correct answer.

< 4000 N 4000 N > 4000 N [1]

(iii) Grace hits the golf ball with a different club.

The force on the ball is the same as before, but the club and ball are in contact for a longer time.

Grace thinks this makes the ball go faster.

Do you agree with Grace?

Use ideas about momentum and time to explain your answer.

.....
.....
.....
..... [2]

[Total: 10]

7
BLANK PAGE

PLEASE DO NOT WRITE ON THIS PAGE

4 (a) Jake is buying an electric car.

- (i) The car's source of energy is a battery, which is connected to an electric motor by metal wires.

A voltmeter is used to measure the voltage across the battery.

Complete the circuit diagram below by connecting the battery to the motor and showing the voltmeter connected correctly.

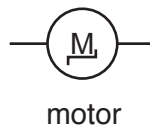
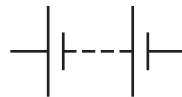

[3]

- (ii) There is an electric current in the connecting wires when the motor is working.

What moves in the wires to cause this electric current?

Put a tick (✓) in the box next to the correct answer.

electrons and protons

electrons only

metal ions

protons only

[1]

- (iii) The diagram shows a switch which can be used to turn the motor on and off.

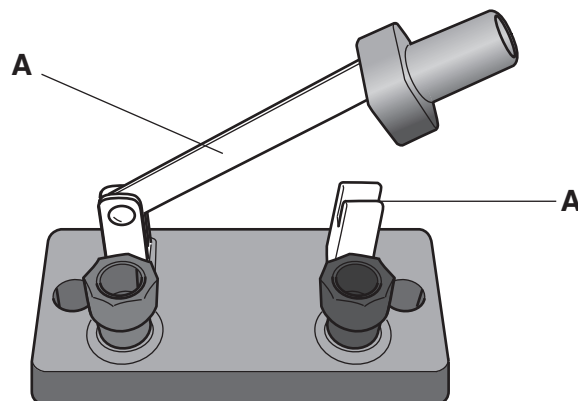

Which of the following materials can be used for the parts labelled **A**?

Put a ring around the **two** correct answers.

aluminium

copper

plastic

wood

[1]

(b) The voltage of the battery is 300 V.

Which is the correct calculation to get the power of the motor when the current is 100A?

Put a ring around the correct answer.

- (100 ÷ 300) (300 ÷ 100) (300 + 100) (300 × 100) [1]

(c) Jake discusses with Sam the advantages and disadvantages of electric cars compared with diesel powered cars.

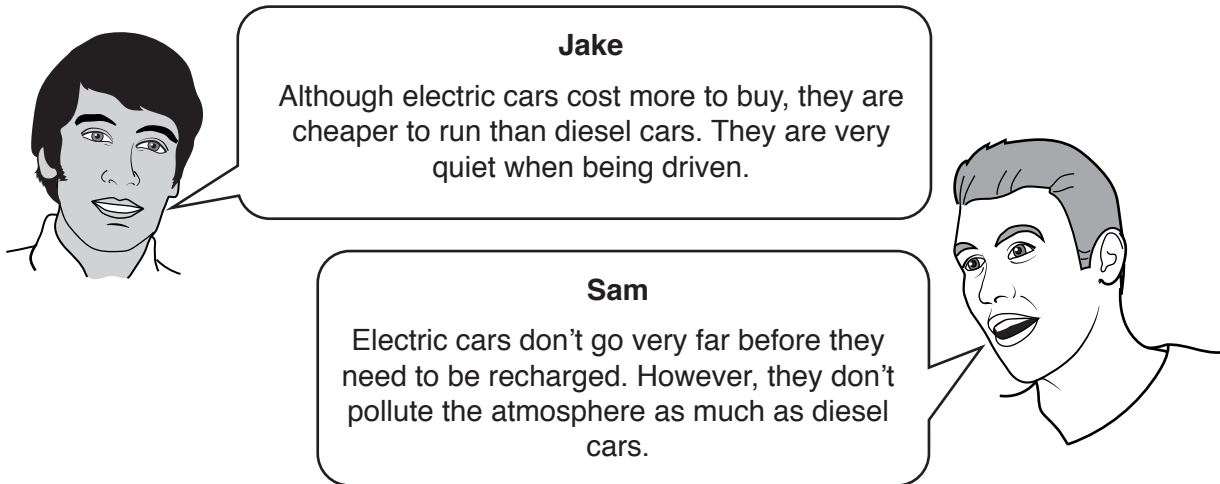

(i) Why do diesel cars pollute the atmosphere more than electric cars?

.....
..... [1]

(ii) Electric cars are very quiet.

Suggest why this might be dangerous for pedestrians.

.....
..... [1]

[Total: 8]

5 Alyssia is doing electricity experiments.

(a) She investigates the current in circuits made from cells and lamps.

All the cells are alike and all the lamps are alike.

Here are four circuits she connects up. Each circuit contains an ammeter.

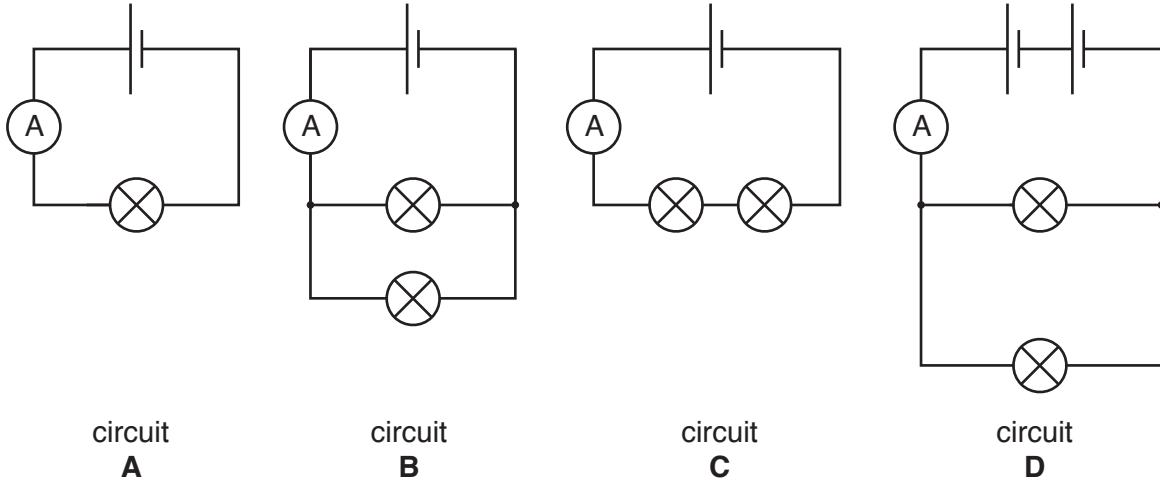

For each statement choose the correct circuit.

Put a letter **A**, **B**, **C** or **D** in each box to show your choice.

You can use each letter once, twice or not at all.

- (i) The ammeter in this circuit has the **smallest** reading. [1]
- (ii) The ammeter in this circuit has the **greatest** reading. [1]
- (iii) In these **TWO** circuits the lamps are connected in **parallel**. and [1]

(b) Alyssia then uses an LDR.

Which is the symbol for an LDR?

Put a ring around the correct symbol.



[1]

(c) Alyssia uses a magnet and a coil of wire to generate electricity.

The coil is connected to a sensitive voltmeter.

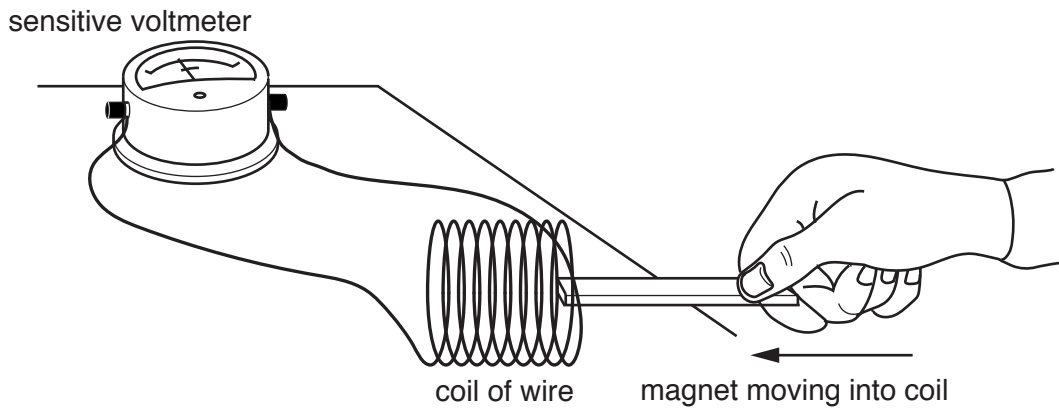

When Alyssia pushes the magnet into the coil the voltmeter reads 2 mV.

(i) What is the reading on the voltmeter when the magnet is held stationary in the coil?

..... [1]

(ii) What can Alyssia do to generate a voltage of 2 mV in the opposite direction?

.....
 [1]

[Total: 6]

6 Zac and Megan are doing an experiment with a thermistor.

They use a 12V power supply and an ammeter and voltmeter connected to the thermistor.

They put the thermistor in a beaker of water and gently heat the water.

They record the voltmeter and ammeter readings as well as the temperature of the water.

Here are their results.

Temperature (°C)	10	20	30	40
Voltage (V)	12	12	12	12
Current (mA)	0.60	1.0	1.5	2.4

Zac says: “There is no correlation between **temperature** and **current**.”

Megan says: “The **resistance** of the thermistor changes as it gets warmer.”

Comment on Zac and Megan's statements.

Use the data to justify your answer.



The quality of written communication will be assessed in your answer.

.....

.....

.....

.....

.....

.....

.....

.....

.....

.....

.....

.....

.....

..... [6]

[Total: 6]

- 7 Draw one straight line from each **word** to its correct **meaning** in the physics of radioactive materials.

Word	Meaning
fusion	contains protons and electrons
	gives out ionising radiation
	contains nuclei which never change
nucleus	a nucleus splits
	nuclei join
radioactive	small, massive and positive part of an atom

[3]

[Total: 3]

15
BLANK PAGE

PLEASE DO NOT WRITE ON THIS PAGE

8 The graph shows how the activity of a radioactive source, X, decreases with time.

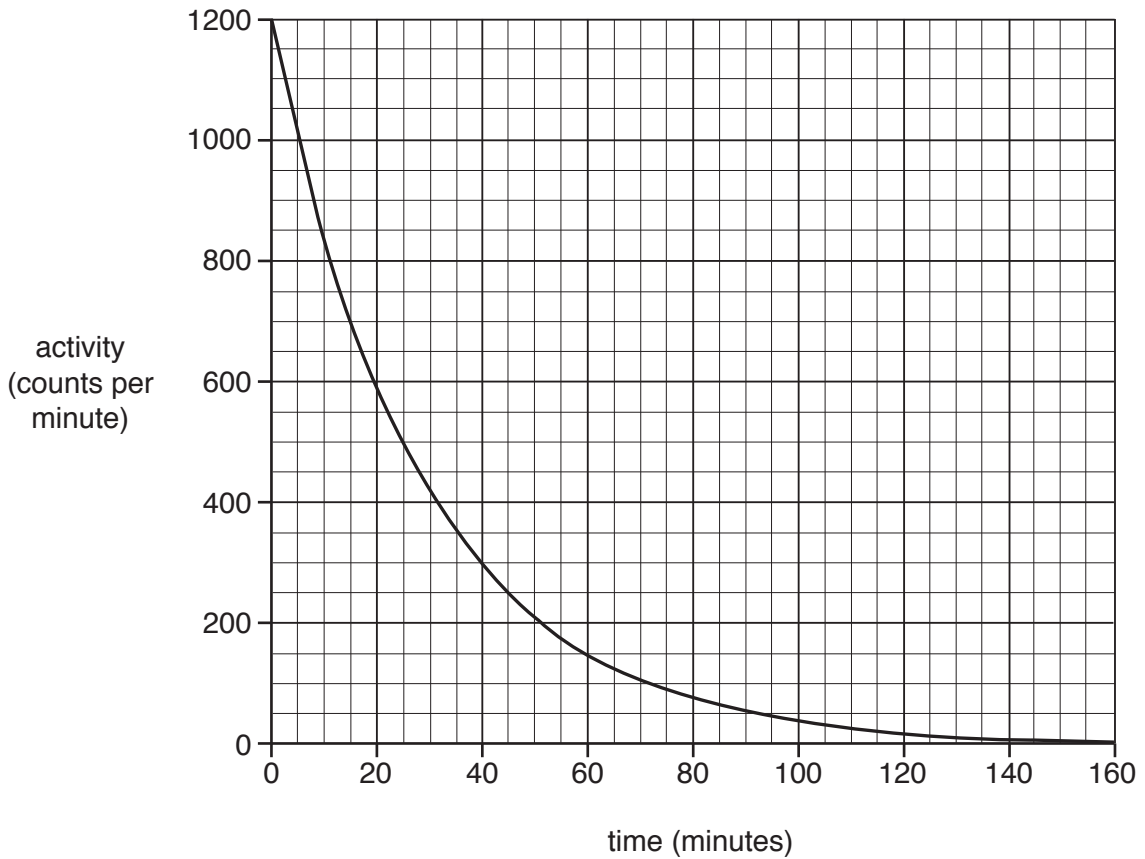

(a) At what time is the activity 200 counts per minute?

Put a ring around the correct answer.

40 minutes

52 minutes

60 minutes

68 minutes

[1]

(b) The half-life of the source is 20 minutes.

Explain how the graph shows this.

Use data from the graph to support your answer.

.....

.....

..... [2]

(c) Another radioactive source, **Y**, has a starting activity of 1200 counts/minute, like **X**.

However, its half-life is **much less than 20 minutes**.

If it is plotted on the same graph, where will the line be?

Put a **ring** around the correct answer.

below the line for X

same place as X

above the line for X

[1]

[Total: 4]

9 Background radiation is slightly higher in areas of the UK where there is granite rock.

Granite is radioactive, emitting gamma rays and radon gas.

Some of the decay products of radon are also radioactive, emitting alpha particles.

These decay products can stick to atmospheric dust. We breathe in this dust and it gets lodged in our lungs.

(a) What is meant by background radiation?

.....
 [1]

(b) Use the information above about granite and radon decay products to explain the difference between **contamination** and **irradiation**.

.....

 [3]

(c) Radioactive materials may also emit beta particles as well as alpha particles and gamma rays.

These radiations are stopped by different materials.

Complete the table by putting a tick (✓) in the box if the material **stops** the radiation passing through.

You may put more than one tick in each row.

Material	Type of radiation		
	Alpha particle	Beta particle	Gamma ray
very thick lead			
3 mm of aluminium			
0.5 m of air			

[3]

[Total: 7]

10 Ryan has been advised by doctors that he needs to have a full-body CT scan.

The CT scan uses ionising radiation in order to produce an image of his internal organs.

Ryan is concerned as he has heard that ionising radiation can damage the body.

He has found the following information about doses of ionising radiation.

	Dose (millisievert)
Average background dose per year	2.7
Lowest dose per year definitely linked to an increase in cancer later in life	100
Fatal dose	5000
Recommended highest dose per year	50
Chest X-ray	0.10
Dental X-ray	0.01
Eating one banana or 100g of Brazil nuts	0.01

The doctors have told Ryan that the CT scan will give him a dose of 10 millisievert.

Describe how ionising radiation can damage the body and explain why the doctors say that the benefits of a CT scan outweigh the risks.

Use the data in your answer.



The quality of written communication will be assessed in your answer.

.....

.....

.....

.....

.....

.....

.....

.....

.....

.....

.....

.....

.....

.....

..... [6]

[Total: 6]

END OF QUESTION PAPER

ADDITIONAL ANSWER SPACE

If additional space is required, you should use the following lined page(s). The question number(s) must be clearly shown in the margin(s).

A large rectangular area with a solid vertical line on the left side and horizontal dotted lines across the rest of the page, providing space for writing answers.



Copyright Information

OCR is committed to seeking permission to reproduce all third-party content that it uses in its assessment materials. OCR has attempted to identify and contact all copyright holders whose work is used in this paper. To avoid the issue of disclosure of answer-related information to candidates, all copyright acknowledgements are reproduced in the OCR Copyright Acknowledgements Booklet. This is produced for each series of examinations and is freely available to download from our public website (www.ocr.org.uk) after the live examination series.

If OCR has unwittingly failed to correctly acknowledge or clear any third-party content in this assessment material, OCR will be happy to correct its mistake at the earliest possible opportunity.

For queries or further information please contact the Copyright Team, First Floor, 9 Hills Road, Cambridge CB2 1GE.

OCR is part of the Cambridge Assessment Group; Cambridge Assessment is the brand name of University of Cambridge Local Examinations Syndicate (UCLES), which is itself a department of the University of Cambridge.