

Tuesday 19 May 2015 – Morning

AS GCE PHYSICS B (ADVANCING PHYSICS)

G491/01 Physics in Action

Candidates answer on the Question Paper.

OCR supplied materials:

- Data, Formulae and Relationships Booklet (sent with general stationery)

Other materials required:

- Electronic calculator
- Ruler (cm/mm)

Duration: 1 hour

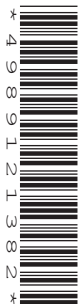

Candidate forename		Candidate surname	
--------------------	--	-------------------	--

Centre number						Candidate number				
---------------	--	--	--	--	--	------------------	--	--	--	--

INSTRUCTIONS TO CANDIDATES

- Write your name, centre number and candidate number in the boxes above. Please write clearly and in capital letters.
- Use black ink. HB pencil may be used for graphs and diagrams only.
- Answer **all** the questions.
- Read each question carefully. Make sure you know what you have to do before starting your answer.
- Show clearly the working in all calculations, and give answers to only a justifiable number of significant figures.
- Write your answer to each question in the space provided. If additional space is required, you should use the lined page(s) at the end of this booklet. The question number(s) must be clearly shown.
- Do **not** write in the bar codes.

INFORMATION FOR CANDIDATES

- The number of marks is given in brackets [] at the end of each question or part question.
- The total number of marks for this paper is **60**.
- You are advised to spend about 20 minutes on Section A and 40 minutes on Section B.
- The values of standard physical constants are given in the Data, Formulae and Relationships Booklet. Any additional data required are given in the appropriate question.



Where you see this icon you will be awarded marks for the quality of written communication in your answer.

This means, for example, you should:

- ensure that text is legible and that spelling, punctuation and grammar are accurate so that meaning is clear;
- organise information clearly and coherently, using specialist vocabulary when appropriate.
- This document consists of **16** pages. Any blank pages are indicated.

Answer **all** the questions.

SECTION A

- 1 Here is a list of electrical units.

As AV AV⁻¹ JC⁻¹ VA⁻¹

From the list select the unit that could be used to measure:

power

charge

conductance

[3]

- 2 The refractive index of a transparent material is 1.7.

Calculate the speed of light in this material.

Give your final answer to an appropriate number of significant figures.

speed of light in vacuum = $3.0 \times 10^8 \text{ m s}^{-1}$

speed of light in material = m s^{-1} **[2]**

- 3 Fig. 3.1 shows a potential divider circuit.

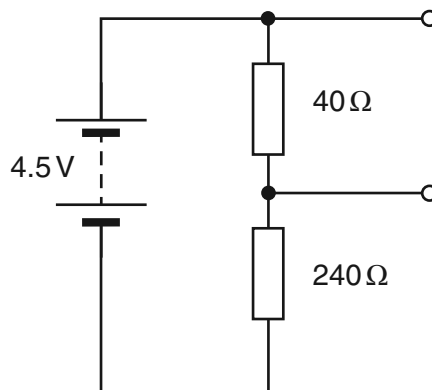

Fig. 3.1

Calculate the potential difference (p.d.) across the 40Ω resistance.

p.d. = V **[2]**

- 4 Fig. 4.1 shows how the frequency of one chirrup of bird song varies with time.

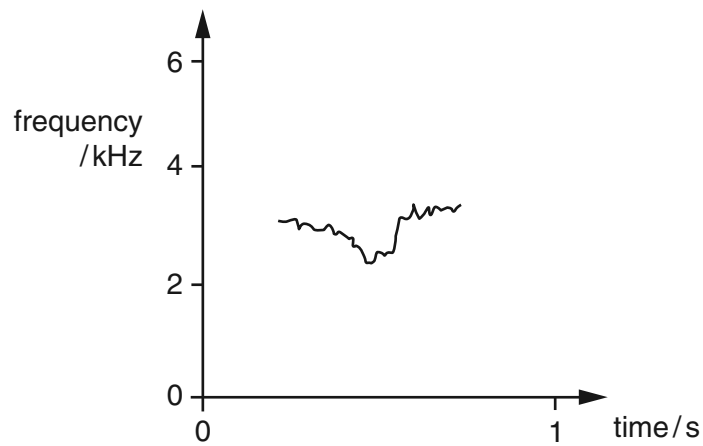

Fig. 4.1

- (a) Describe **two** aspects of the frequency variation of the chirrup shown in Fig. 4.1.

1

2

[1]

- (b) Estimate the total number of oscillations represented by the frequency variation in Fig. 4.1.

Make your method clear.

number of oscillations = [2]

5 Fig. 5.1 compares the frequency range of human speech with that of orchestral music.

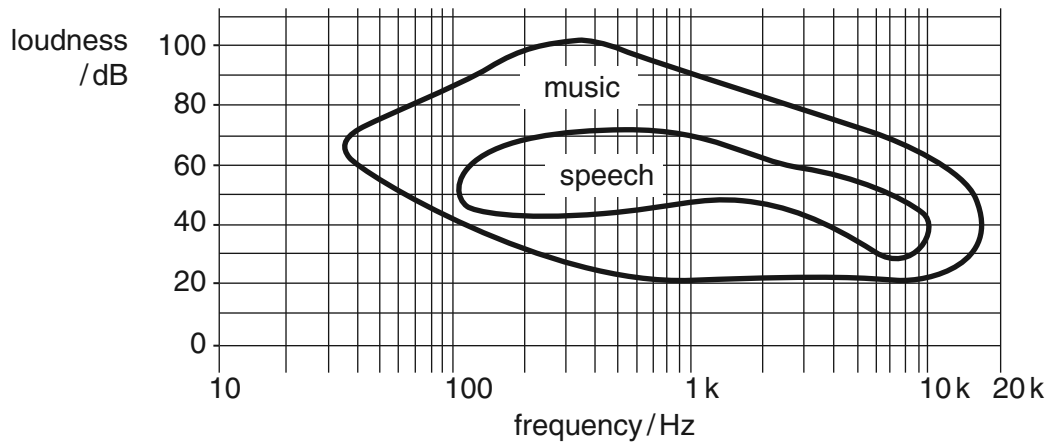

Fig. 5.1

(a) State how you recognise that the frequency scale is logarithmic.

[1]

(b) State the frequency f of the loudest sound in orchestral music.

$f = \dots\dots\dots$ Hz [1]

(c) Calculate the bandwidth for human speech.

bandwidth = $\dots\dots\dots$ Hz [1]

- 6 A long-sighted person has a near point at 1.25 m from the eye. This is the smallest object distance from their eye for comfortable vision.

(a) Calculate the curvature of waves arriving at the eye from a distance of 1.25 m.

curvature = - D [1]

- (b) A person with a near point at 1.25 m needs spectacles to read a book at a distance of 0.25 m from their eye.

Calculate the power of the spectacle lens needed for this.

Make your method clear.

power of lens = D [2]

7 Fig. 7.1 shows how the voltage of a lithium-ion rechargeable battery varies with time as it discharges into a constant load of $5.0\ \Omega$.

Graphs for temperatures of 50°C and -20°C are given.

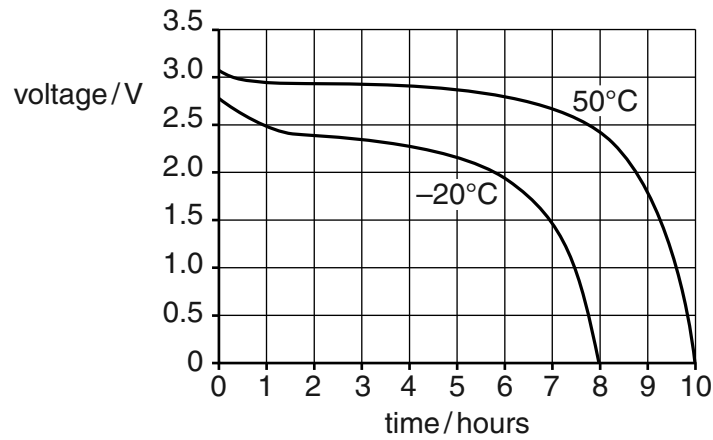

Fig. 7.1

(a) State **two** effects of changing temperature on the voltage variation.

1

2

[2]

(b) 1 Use data from Fig. 7.1 to estimate the average current delivered by the battery when operating at 50°C . The load is constant at $5.0\ \Omega$.

average current = A [1]

2 Estimate the charge delivered by the battery in one complete discharge when operating at 50°C . Make your method clear.

charge delivered = C [2]

[Section A Total: 21]

Section B starts on page 8

PLEASE DO NOT WRITE ON THIS PAGE

8
SECTION B

8 Fig. 8.1 shows the graph of current against p.d. for a 6.0V tungsten filament lamp.

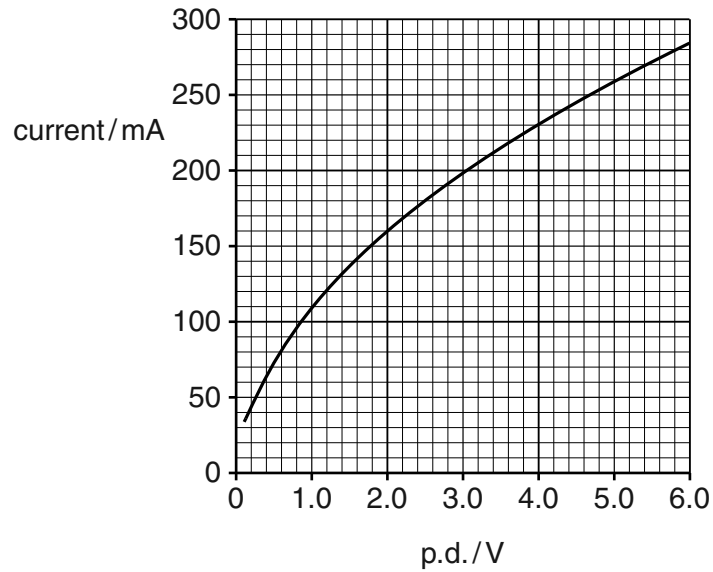

Fig. 8.1

(a) State how data from the graph indicates that the filament is **not** obeying Ohm's law.

[1]

(b) (i) Complete the table of Fig. 8.2 which shows data for the smallest and largest p.d. readings displayed in the graph.

p.d./V	current/mA	resistance/ Ω	power/W
0.11	35		0.0039
6.00			

Fig. 8.2

[3]

(ii) State and explain why the filament in the lamp is not obeying Ohm's law.

You do not need to discuss the metal microstructure.

[2]

- (iii) The filament is made of tungsten wire of cross-sectional area $3.2 \times 10^{-10} \text{ m}^2$.

resistivity of tungsten at 20°C , $\rho_{20} = 5.6 \times 10^{-8} \Omega \text{ m}$

Calculate the length of wire needed to make the filament.

State any assumption made.

length = m [3]

- (iv) The tungsten of the filament heats to about 3000°C when working at 6.0V.

Estimate the value of $\frac{\rho_{3000}}{\rho_{20}}$.

Assume that changes in filament dimensions during warming are not significant.

Make your reasoning clear.

$\frac{\rho_{3000}}{\rho_{20}} = \dots\dots\dots$ [2]

- (c) Explain in terms of microstructure why metals are good conductors of electricity. Suggest why the resistivity of tungsten might alter with temperature.



Make your explanation clear and use technical terms spelled correctly in your answer.

9 Fig. 9.1 shows the stress against strain graphs for four metal alloys **A**, **B**, **C** and **D** to their breaking points.

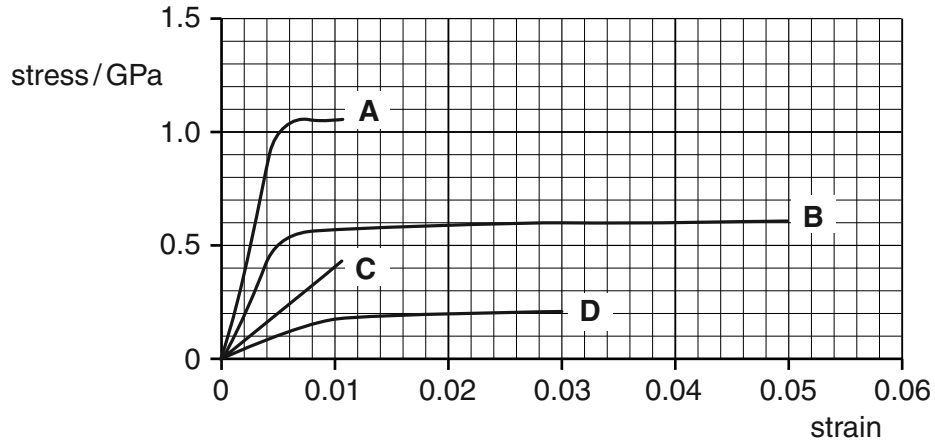

Fig. 9.1

(a) State which metal alloy

- (i) has the lowest Young modulus
- (ii) has the highest tensile strength
- (iii) has the greatest plastic region

[3]

(b) (i) Calculate the Young modulus for alloy **C**.

Young modulus = Pa [2]

(ii) A cable made of alloy **C** of length 420m is stretched until its strain is 0.0075.
Calculate the extension of this cable.

extension = m [2]

- (c) Many objects are made of metal alloys. Two examples are (i) the cables for a lift and (ii) the section of a car which crumples during a collision.

State with reasons which alloy **A**, **B**, **C** or **D** you would choose for each application. Explain how its microstructure could lead to the desirable mechanical behaviour as shown on Fig. 9.1.



Use technical terms spelled correctly in your answer.

- (i) the cables for a lift: alloy

[3]

- (ii) the section of a car which crumples during a collision: alloy

[3]

- 10 Fig. 10.1 shows an image made with atoms using a scanning tunnelling microscope. The image is less than 100 atoms wide.

Image removed due to third party copyright restrictions

Fig. 10.1

- (a) The greyscale of the image has 16 alternative intensity levels.

(i) Show that 4 bits are needed for 16 levels.

[1]

- (ii) Calculate the maximum number of bytes needed to store the image of Fig. 10.1.

maximum number = bytes [2]

- (iii) The image from Fig. 10.1 is one frame from the movie, "A boy with his atom". The movie lasts for 90s at a rate of 5 images per second.

Calculate the maximum number of bytes needed to store the movie.

maximum number = bytes [1]

(b) The diameter of the atoms used to make the movie is 270 pm.

Take measurements from Fig. 10.1 to calculate the magnification of the atoms in this image.

magnification = [1]

(c) Use Fig. 10.1 to estimate the resolution of the image. Make your method clear.

resolution = m pixel⁻¹ [2]

Question 10(d) begins on page 14

- (d) A scanning tunnelling microscope (STM) positions a sharp tip at a height h above a flat surface as shown in Fig. 10.2a. When a p.d. is applied, there is a tiny ‘tunnelling’ current between the tip and the surface. The current varies rapidly with changes in h , as shown in Fig. 10.2b, so that small changes in h can be measured.

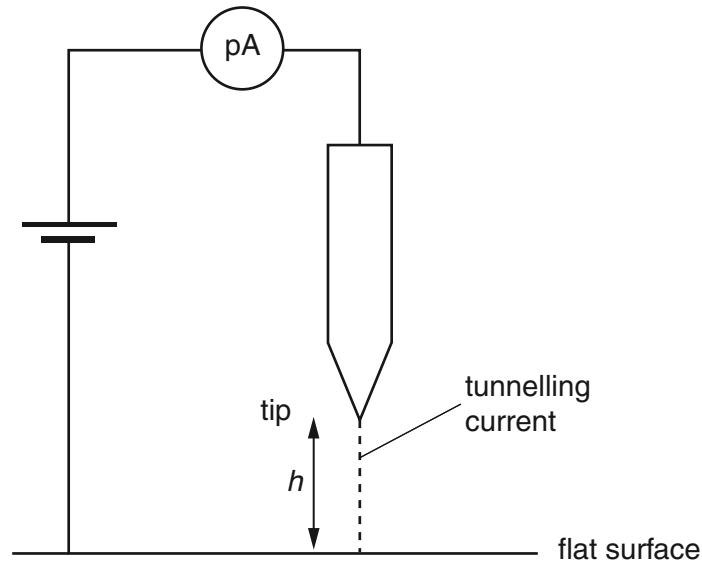

Fig. 10.2a

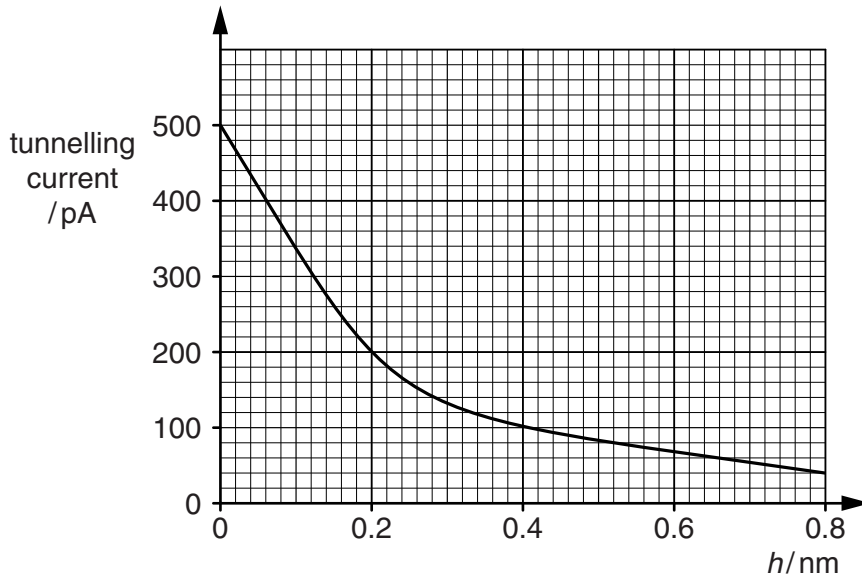

Fig. 10.2b

- (i) The sensitivity of the STM is defined as the gradient of the graph. Calculate the sensitivity at height h of 0.25 nm which is about one atomic diameter.

sensitivity =pA nm⁻¹ [2]

- (ii) Fig. 10.3 shows three atoms, of diameter 0.25 nm, on a surface. The tip of the STM is scanned across the surface at a constant height h of 0.40 nm above the surface.

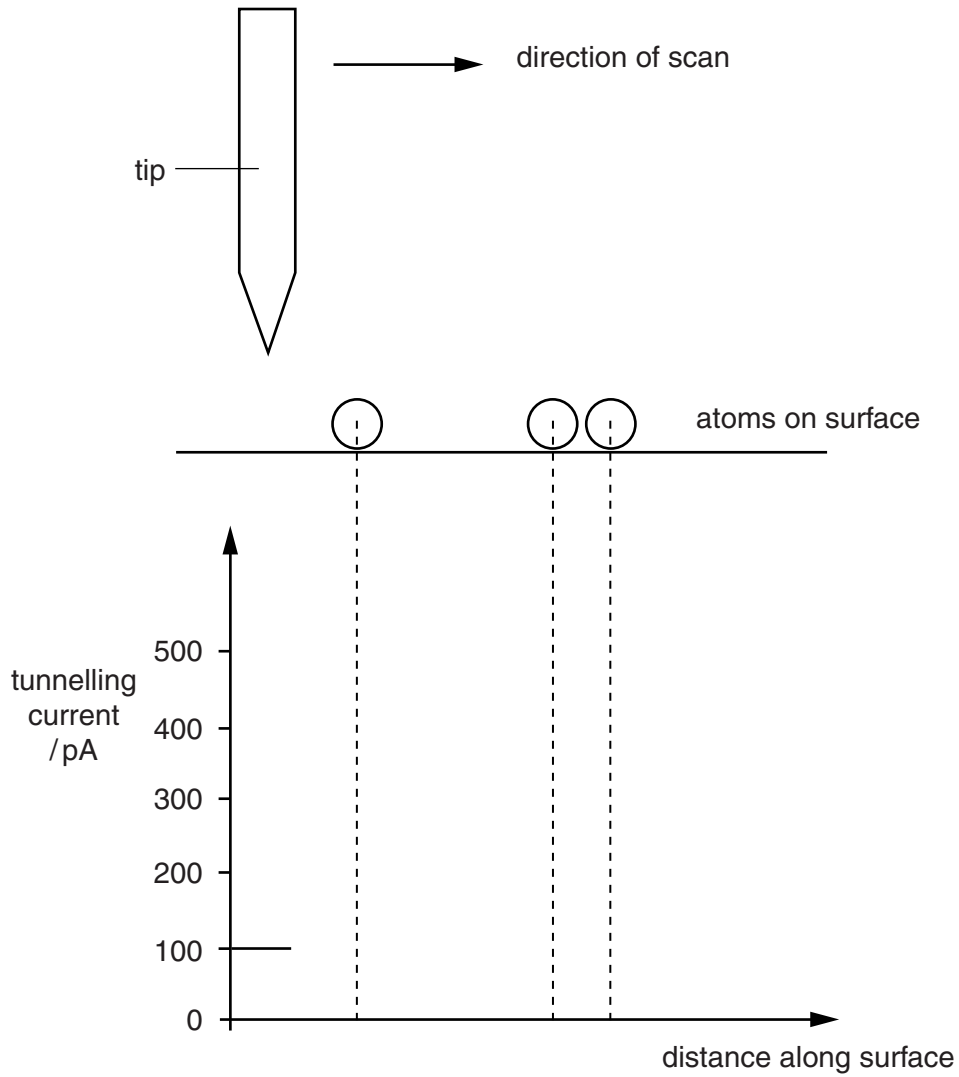

Fig. 10.3

On the axes shown on Fig. 10.3, use the data from 10.2b to draw the graph of tunnelling current against distance along the surface. The graph has been started for you. [2]

- (iii) Suggest how the graph you have drawn in Fig. 10.3 shows how the image in Fig. 10.1 was produced. [1]

[Section B Total: 39]

END OF QUESTION PAPER

ADDITIONAL ANSWER SPACE

If additional answer space is required, you should use the following lined page(s). The question number(s) must be clearly shown in the margin(s).

A large rectangular area with a vertical solid line on the left side and horizontal dotted lines across the rest of the page, providing space for writing answers.



Copyright Information

OCR is committed to seeking permission to reproduce all third-party content that it uses in its assessment materials. OCR has attempted to identify and contact all copyright holders whose work is used in this paper. To avoid the issue of disclosure of answer-related information to candidates, all copyright acknowledgements are reproduced in the OCR Copyright Acknowledgements Booklet. This is produced for each series of examinations and is freely available to download from our public website (www.ocr.org.uk) after the live examination series.

If OCR has unwittingly failed to correctly acknowledge or clear any third-party content in this assessment material, OCR will be happy to correct its mistake at the earliest possible opportunity.

For queries or further information please contact the Copyright Team, First Floor, 9 Hills Road, Cambridge CB2 1GE.

OCR is part of the Cambridge Assessment Group; Cambridge Assessment is the brand name of University of Cambridge Local Examinations Syndicate (UCLES), which is itself a department of the University of Cambridge.