

Centre Number						Candidate Number				
Surname										
Other Names										
Candidate Signature										

For Examiner's Use	
Examiner's Initials	
Question	Mark
1	
2	
3	
4	
5	
6	
TOTAL	



General Certificate of Secondary Education
Higher Tier
January 2013

Additional Science
Unit Physics P2

PH2HP
H

Physics
Unit Physics P2

Friday 25 January 2013 1.30 pm to 2.30 pm

For this paper you must have:

- a ruler
- a calculator
- the Physics Equations Sheet (enclosed).

Time allowed

- 1 hour

Instructions

- Use black ink or black ball-point pen.
- Fill in the boxes at the top of this page.
- Answer **all** questions.
- You must answer the questions in the spaces provided. Do not write outside the box around each page or on blank pages.
- Do all rough work in this book. Cross through any work you do not want to be marked.

Information

- The marks for questions are shown in brackets.
- The maximum mark for this paper is 60.
- You are expected to use a calculator where appropriate.
- Question 3(c) should be answered in continuous prose. In this question you will be marked on your ability to:
 - use good English
 - organise information clearly
 - use specialist vocabulary where appropriate.

Advice

- In all calculations, show clearly how you work out your answer.



J A N 1 3 P H 2 H P 0 1

Answer **all** questions in the spaces provided.

1 A car has an oil leak. Every 5 seconds an oil drop falls from the bottom of the car onto the road.

1 (a) What force causes the oil drop to fall towards the road?

.....
(1 mark)

1 (b) The diagram shows the spacing of the oil drops left on the road during part of a journey from A to B.



Describe the motion of the car as it moves from **A** to **B**.

.....

Explain the reason for your answer.

.....
.....
.....
.....

(3 marks)

1 (c) When the brakes are applied, a braking force slows down and stops the car.

1 (c) (i) The size of the braking force affects the braking distance of the car.

State **one** other factor that affects the braking distance of the car.

.....
(1 mark)



1 (c) (ii) A braking force of 3 kN is used to slow down and stop the car in a distance of 25 m.

Calculate the work done by the brakes to stop the car and give the unit.

Use the correct equation from the Physics Equations Sheet.

.....

.....

.....

Work done =

(3 marks)

8

Turn over for the next question

Turn over ►



- 2 (a)** A teacher used a Geiger-Müller (GM) tube and counter to measure the *background radiation* in her laboratory.

The teacher reset the counter to zero, waited one minute and then took the count reading. The teacher repeated the procedure two more times.

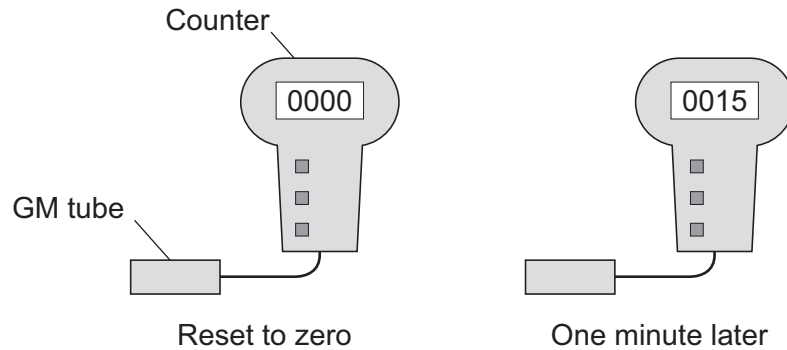

- 2 (a) (i)** Background radiation can be either from natural sources or from man-made sources.

Name **one man-made** source of background radiation.

.....
(1 mark)

- 2 (a) (ii)** The three readings taken by the teacher are given in the table.

Count after one minute
15
24
18

The readings given in the table are correct.

Why are the readings different?

.....
.....
(1 mark)



- 2 (b)** Some scientists say they have found evidence to show that people living in areas of high natural background radiation are less likely to develop cancer than people living in similar areas with lower background radiation.

The evidence these scientists found does not definitely mean that the level of background radiation determines whether a person will develop cancer.

Suggest a reason why.

.....

(1 mark)

- 2 (c)** An atom of the isotope radon-222 emits an alpha particle and decays into an atom of polonium.

An alpha particle is the same as a helium nucleus. The symbol below represents an alpha particle.



- 2 (c) (i)** How many protons and how many neutrons are there in an alpha particle?

Number of protons =

Number of neutrons =

(2 marks)

- 2 (c) (ii)** The decay of radon-222 can be represented by the equation below.

Complete the equation by writing the correct number in each of the **two** boxes.

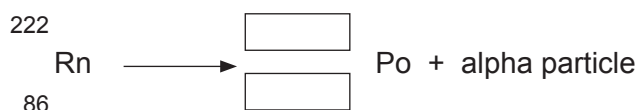

(2 marks)

Question 2 continues on the next page

Turn over ►



- 2 (d) The graph shows how, in a sample of air, the number of radon-222 nuclei changes with time.

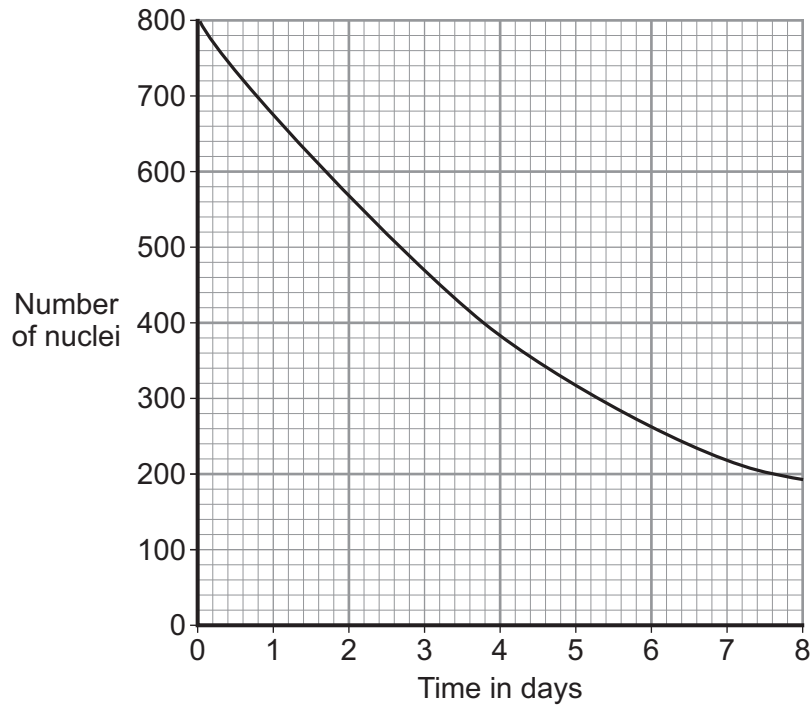

Use the graph to find the half-life of radon-222.

Show clearly on the graph how you obtain your answer.

Half-life = days
(2 marks)



3 Stars go through a life cycle. About 90% of all stars are in the 'main sequence' period of the life cycle.

3 (a) Stars are stable during the 'main sequence' period of the life cycle.

Why?

.....

.....

(1 mark)

3 (b) The table gives an estimated time for the number of years that three stars, **X**, **Y** and **Z**, will be in the 'main sequence' period of their life cycle.

Star	Relative mass of the star compared to the Sun	Estimated 'main sequence' period in millions of years
X	0.1	4 000 000
Y	1.0	9 000
Z	40.0	200

3 (b) (i) This data suggests that there is a pattern linking the mass of a star and the number of years the star is in the 'main sequence' period of its life cycle.

What is the pattern suggested by the data?

.....

.....

(1 mark)

3 (b) (ii) Scientists cannot give the exact number of years a star will be in the 'main sequence' period.

Suggest why.

.....

.....

(1 mark)

Question 3 continues on the next page

Turn over ►



3 (b) (iii) Nuclear fusion is the process by which energy is released in stars.

Which **one** of the following can be concluded from the data in the table?

Draw a ring around the correct answer in the box to complete the sentence.

The rate of nuclear fusion in a large star is

faster than

the same as

in a small star.

slower than

Explain the reason for your answer.

.....

.....

.....

.....

(3 marks)



4 (a) A student set up the circuit shown in the diagram. The student uses the circuit to obtain the data needed to plot a current - potential difference graph for a diode.

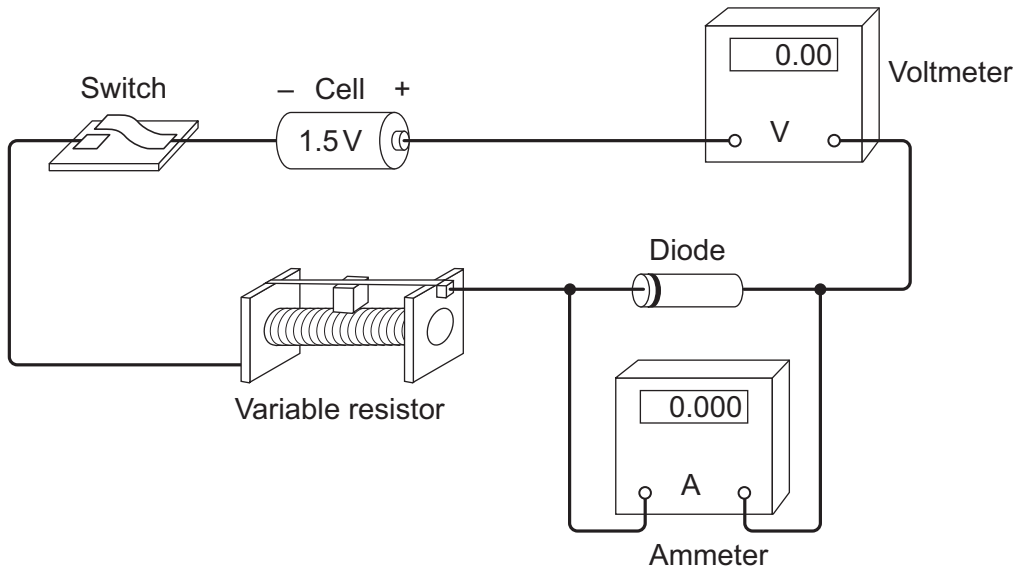

4 (a) (i) Draw, in the boxes, the circuit symbol for a diode and the circuit symbol for a variable resistor.

Diode

Variable resistor

(2 marks)

4 (a) (ii) The student made two mistakes when setting up the circuit.

What **two** mistakes did the student make?

1

.....

2

.....

(2 marks)



4 (b) After correcting the circuit, the student obtained a set of data and plotted the graph below.

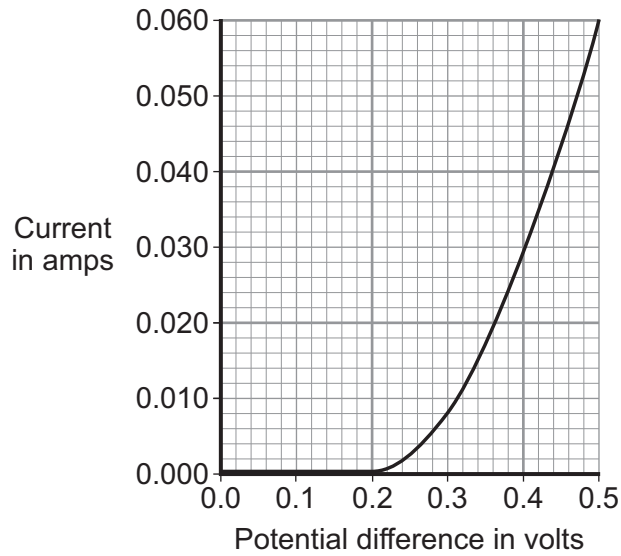

4 (b) (i) At what potential difference did the diode start to conduct an electric current?

..... V
(1 mark)

4 (b) (ii) Use data from the graph to calculate the resistance of the diode when the potential difference across the diode is 0.3V.

Use the correct equation from the Physics Equations Sheet.

.....
.....
.....

Resistance = ohms
(3 marks)

Question 4 continues on the next page

Turn over ►



4 (c) The diagram shows the trace produced by an alternating current (a.c.) supply on an oscilloscope.

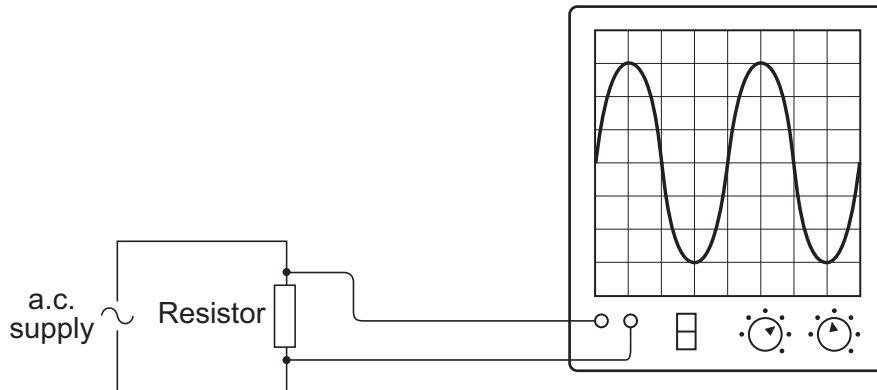

Each horizontal division on the oscilloscope screen represents a time of 0.01s.

4 (c) (i) Calculate the frequency of the a.c. supply.

.....

.....

.....

Frequency = hertz
(2 marks)



4 (c) (ii) A diode is now connected in series with the a.c. power supply.

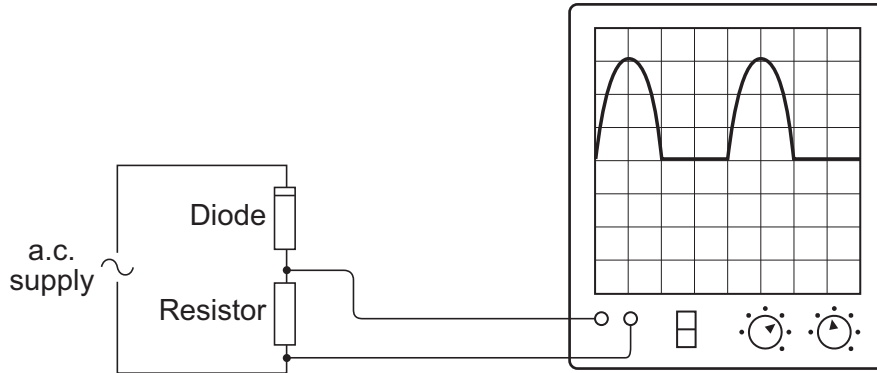

Why does the diode cause the trace on the oscilloscope screen to change?

.....

.....

.....

.....

(2 marks)

12

Turn over for the next question

Turn over ▶



5 (a) Some students have designed and built an electric-powered go-kart. After testing, the students decided to make changes to the design of their go-kart.

First design **X**

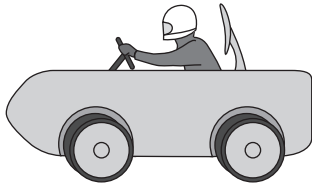

Final design **Y**

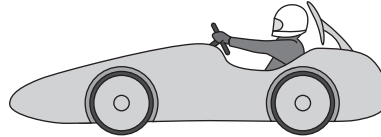

The go-kart always had the same mass and used the same motor.

The change in shape from the first design (**X**) to the final design (**Y**) will affect the top speed of the go-kart.

Explain why.

.....

.....

.....

.....

.....

.....

(3 marks)

5 (b) The final design go-kart, **Y**, is entered into a race.

The graph shows how the velocity of the go-kart changes during the first 40 seconds of the race.

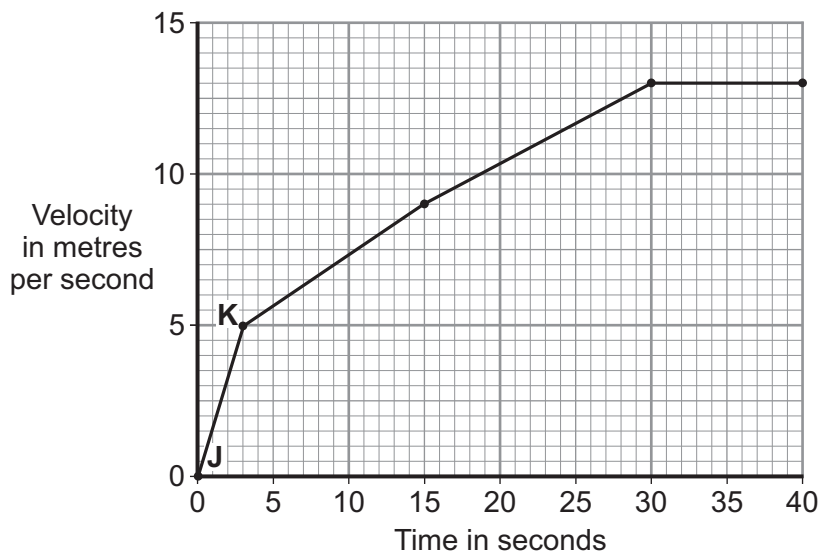

5 (b) (i) Use the graph to calculate the acceleration of the go-kart between points **J** and **K**.

Give your answer to **two** significant figures.

.....
.....
.....

Acceleration = m/s²
(2 marks)

5 (b) (ii) Use the graph to calculate the distance the go-kart travels between points **J** and **K**.

.....
.....
.....

Distance = m
(2 marks)

5 (b) (iii) What causes most of the resistive forces acting on the go-kart?

.....

(1 mark)

8

Turn over for the next question

Turn over ►



6 The diagram shows the structure of a cable. The cable is part of an undersoil heating circuit inside a large greenhouse.

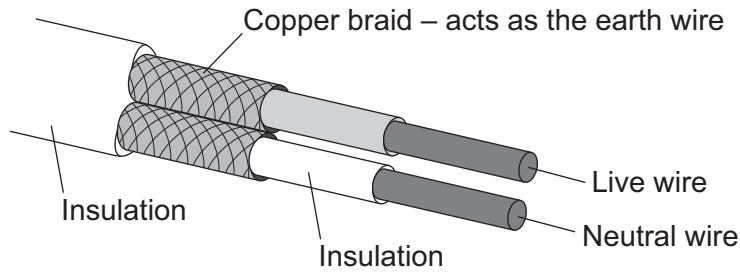

6 (a) The cable is connected to the mains electricity supply through a residual current circuit breaker (RCCB). If the cable is accidentally cut the RCCB automatically switches the circuit off.

6 (a) (i) What is the frequency of the mains electricity supply in the UK?

.....
(1 mark)

6 (a) (ii) What happens, as the cable is cut, to cause the RCCB to switch the circuit off?

.....
.....
.....
.....
(2 marks)

6 (a) (iii) A circuit can also be switched off by the action of a fuse.

Give **one** advantage of using a RCCB to switch off a circuit rather than a fuse.

.....
.....
(1 mark)



6 (b) The 230 volt mains electricity supply causes a current of 11 amps to flow through the cable.

6 (b) (i) Calculate the amount of charge that flows through the cable when the cable is switched on for 2 hours and give the unit.

Use the correct equation from the Physics Equations Sheet.

.....
.....
.....

Charge =
(3 marks)

6 (b) (ii) Calculate the energy transferred from the cable to the soil in 2 hours.

Use the correct equation from the Physics Equations Sheet.

.....
.....

Energy transferred = J
(2 marks)

6 (c) The heating circuit includes a thermistor. The thermistor is buried in the soil and acts as a thermostat to control the increase in the temperature of the soil.

Describe how an **increase** in the temperature of the soil affects the thermistor.

.....
.....
.....
.....

(2 marks)

11

END OF QUESTIONS



There are no questions printed on this page

**DO NOT WRITE ON THIS PAGE
ANSWER IN THE SPACES PROVIDED**



There are no questions printed on this page

**DO NOT WRITE ON THIS PAGE
ANSWER IN THE SPACES PROVIDED**



There are no questions printed on this page

**DO NOT WRITE ON THIS PAGE
ANSWER IN THE SPACES PROVIDED**

