

**Thursday 9 June 2016 – Morning**

**GCSE MATHEMATICS B**

**J567/04** Paper 4 (Higher Tier)

Candidates answer on the Question Paper.

**OCR supplied materials:**

None

**Other materials required:**

- Geometrical instruments
- Tracing paper (optional)
- Scientific or graphical calculator

**Duration:** 1 hour 45 minutes



Candidate forename		Candidate surname	
-----------------------	--	----------------------	--

Centre number						Candidate number				
---------------	--	--	--	--	--	------------------	--	--	--	--

### INSTRUCTIONS TO CANDIDATES

- Write your name, centre number and candidate number in the boxes above. Please write clearly and in capital letters.
- Use black ink. HB pencil may be used for graphs and diagrams only.
- Answer **all** the questions.
- Read each question carefully. Make sure you know what you have to do before starting your answer.
- Your answers should be supported with appropriate working. Marks may be given for a correct method even if the answer is incorrect.
- Write your answer to each question in the space provided. Additional paper may be used if necessary but you must clearly show your candidate number, centre number and question number(s).
- Do **not** write in the bar codes.

### INFORMATION FOR CANDIDATES

- The number of marks is given in brackets [ ] at the end of each question or part question.
- Use the  $\pi$  button on your calculator or take  $\pi$  to be 3.142 unless the question says otherwise.
- The quality of written communication is assessed in questions marked with an asterisk (\*).
- The total number of marks for this paper is **100**.
- This document consists of **24** pages. Any blank pages are indicated.

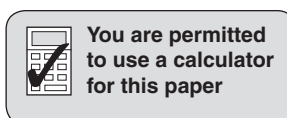

## Formulae Sheet: Higher Tier

**Area of trapezium** =  $\frac{1}{2}(a + b)h$

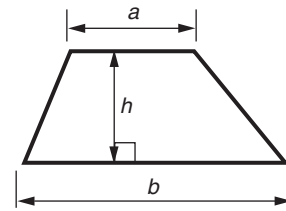

**Volume of prism** = (area of cross-section)  $\times$  length

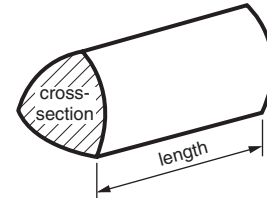

**In any triangle ABC**

**Sine rule**  $\frac{a}{\sin A} = \frac{b}{\sin B} = \frac{c}{\sin C}$

**Cosine rule**  $a^2 = b^2 + c^2 - 2bc \cos A$

**Area of triangle** =  $\frac{1}{2}ab \sin C$

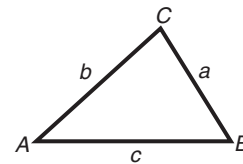

**Volume of sphere** =  $\frac{4}{3}\pi r^3$

**Surface area of sphere** =  $4\pi r^2$

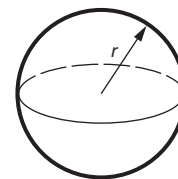

**Volume of cone** =  $\frac{1}{3}\pi r^2 h$

**Curved surface area of cone** =  $\pi r l$

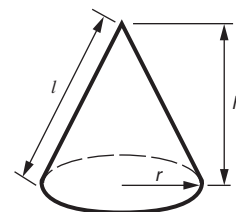

**The Quadratic Equation**

The solutions of  $ax^2 + bx + c = 0$ ,  
where  $a \neq 0$ , are given by

$$x = \frac{-b \pm \sqrt{b^2 - 4ac}}{2a}$$

**PLEASE DO NOT WRITE ON THIS PAGE**

Answer **all** the questions.

- 1 (a) In a game Ted can win, draw or lose.  
The probability that he wins is 0.38.  
The probability that he draws is 0.47.

Work out the probability that Ted loses.

(a) ..... [2]

- (b) In a different game, Theresa can win or lose.  
The probability that she loses the next game is four times the probability that she wins the next game.

Work out the probability that Theresa wins the next game.

(b) ..... [2]

2 Alan grows one group of tomato plants using fertiliser A and a second group of tomato plants using fertiliser B.

(a)\* The stem and leaf diagrams show the heights, in centimetres, of the plants after a certain time.

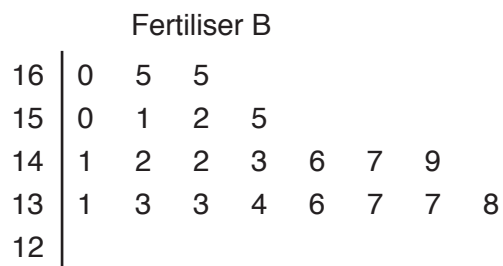
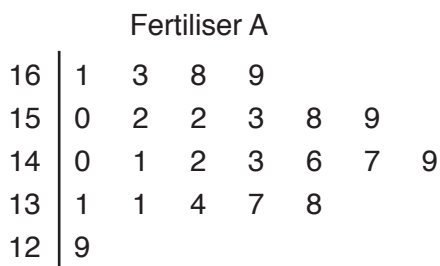

Key: 16 | 3 = 163

Make two different comparisons between the **heights** of the plants in the two groups. Give evidence to support your comparisons.

.....

.....

.....

.....

.....

.....

.....

.....

.....

.....

.....

.....

..... [6]

(b) The scatter diagram shows the height of each plant and the mass, in kilograms, of tomatoes it produces when fertiliser A was used.

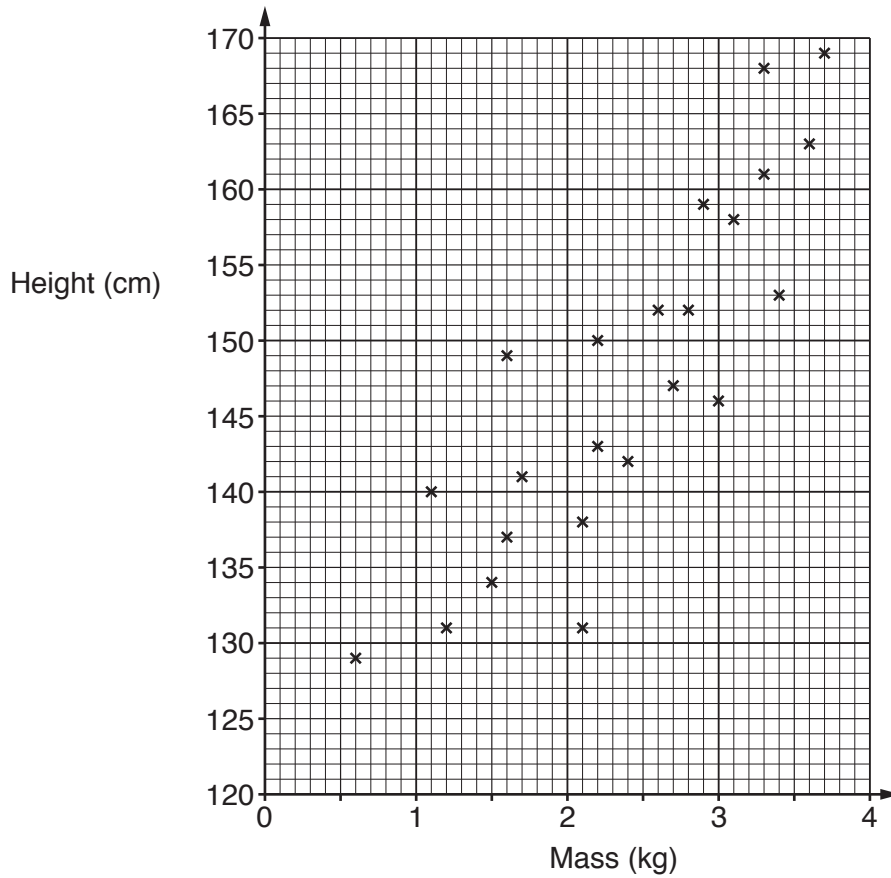

(i) Write down the greatest mass of tomatoes produced by one of these plants.

(b)(i) ..... kg [1]

(ii) How many of these plants produced at least 2.5 kg of tomatoes?

(ii) ..... [1]

(iii) Describe the correlation.

(iii) ..... [1]

(iv) Draw a line of best fit on the diagram.

[1]

(v) Estimate the mass of tomatoes produced by a plant of height 155 cm.

(v) ..... kg [1]

3 Calculate.

(a)

$$\sqrt{\frac{18.62}{2.78 + 6.72}}$$

(a) ..... [2]

(b)

$$3.6 \times 4.5^2 - (12.3 - 8.9)^2$$

(b) ..... [2]

- 4 The equation  $x^3 + 6x = 500$  has a solution between  $x = 7$  and  $x = 8$ .

Find this value of  $x$  correct to 1 decimal place.  
Show clearly your trials and the values of their outcomes.

..... [3]

- 5 Rory uses a bank card.  
He gets money back on his spending.  
The table shows the percentage of his spending he gets back for each category.

Spending category	Money back
Groceries	3%
Fuel	1%
Clothes	0.5%
Everything else	Nil

Rory's total spending on his card was £680 on groceries, £320 on technology, £112 on entertainment, £88 on clothes and £74 on fuel.

Work out the percentage of Rory's total spending on his card that he gets back.  
Give your answer correct to 1 decimal place.

..... % [6]



- 6 The diagram shows a logo.  
One end of the rectangle is the diameter of the circle.

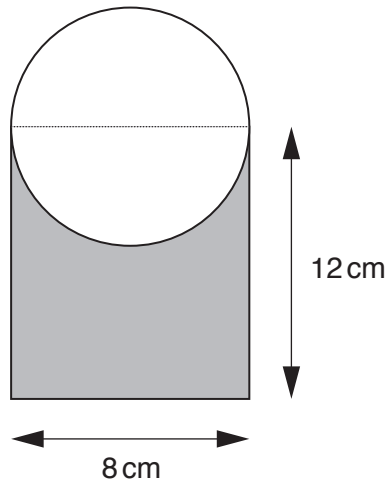

Not to scale

Calculate the shaded area.

..... cm<sup>2</sup> [4]

7 Here are parts of three recipes for fruit punch.

Recipe A  
150 ml pineapple juice  
.....  
.....  
makes 850 ml

Recipe B  
220 ml pineapple juice  
.....  
.....  
makes 1200 ml

Recipe C  
175 ml pineapple juice  
.....  
.....  
makes 1 litre

Which of these three has the highest **proportion** of pineapple juice?  
Show clearly how you decide.

..... [3]

8 The diagram shows a prism, made from two isosceles triangles and three rectangles.

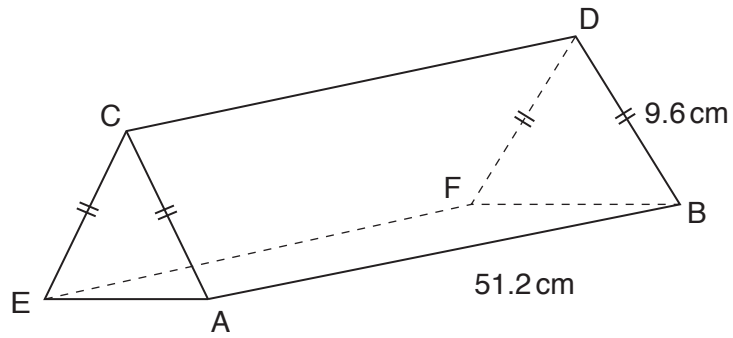

$AC = CE$ ,  $AB = 51.2$  cm and  $BD = 9.6$  cm.

A spider walks from A to the midpoint, M, of CD and then to F.

Calculate the shortest distance that the spider can walk from A to M to F.  
Write your answer correct to 3 significant figures.  
Show how you worked out your answer.

..... cm [5]

- 9 (a) In the diagram, PR is parallel to ST.  
 Angle NRP =  $57^\circ$  and angle RPS =  $78^\circ$ .

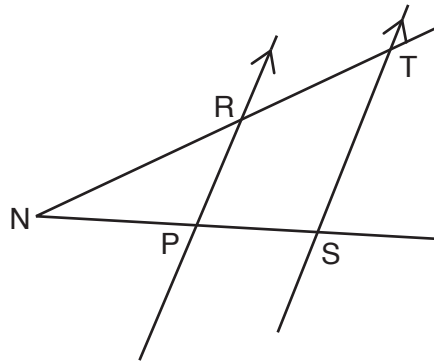

Not to scale

Work out angle RTS.  
 Give a reason for your answer.

angle RTS = ..... $^\circ$  because .....  
 ..... [2]

- (b) In the diagram line GHL is parallel to line JKM.  
 Angle HJK =  $63^\circ$  and angle JHK =  $32^\circ$ .

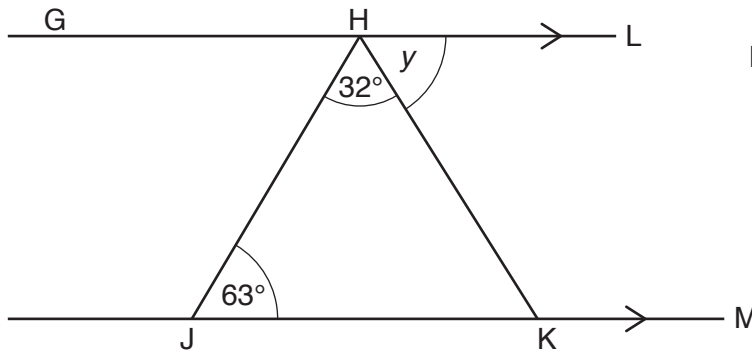

Not to scale

Calculate angle  $y$ .

(b) ..... $^\circ$  [2]

- (c) In the diagram, the points A, B and C lie on the circumference of the circle, centre O.  
Angle BAO =  $42^\circ$ .

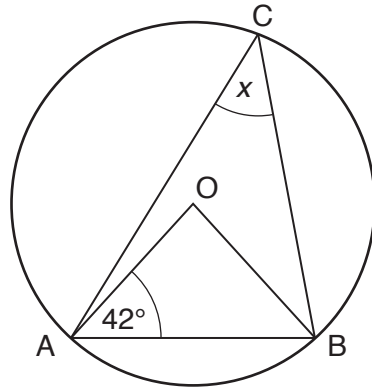

Not to scale

Calculate angle  $x$ .  
Give reasons for each angle you work out.

(c) .....  $^\circ$  [4]

10 (a) Solve.

$$12x - 3 = 4x + 15$$

(a)  $x = \dots\dots\dots$  [3]

(b) Here are the first four terms of a sequence.

12      21      30      39

Write an expression for the  $n$ th term of this sequence.

(b)  $\dots\dots\dots$  [2]

- 11 A boat sails 120 km from port A on a bearing of  $030^\circ$  to port B. It then turns and sails on a bearing of  $200^\circ$  to port C. Port C is due South of port A.

Calculate the distance from port B to port C.

..... km [5]

12 The table shows the temperature at a weather station every six hours for four days.

	Monday				Tuesday			
<b>Time</b>	2am	8am	2pm	8pm	2am	8am	2pm	8pm
<b>Temperature (°C)</b>	0	3	8	4	-1	2	6	3

	Wednesday				Thursday			
<b>Time</b>	2am	8am	2pm	8pm	2am	8am	2pm	8pm
<b>Temperature (°C)</b>	-1	3	4	3	-3	2	3	1

These results have been plotted on the graph with the daily 4-point moving average.



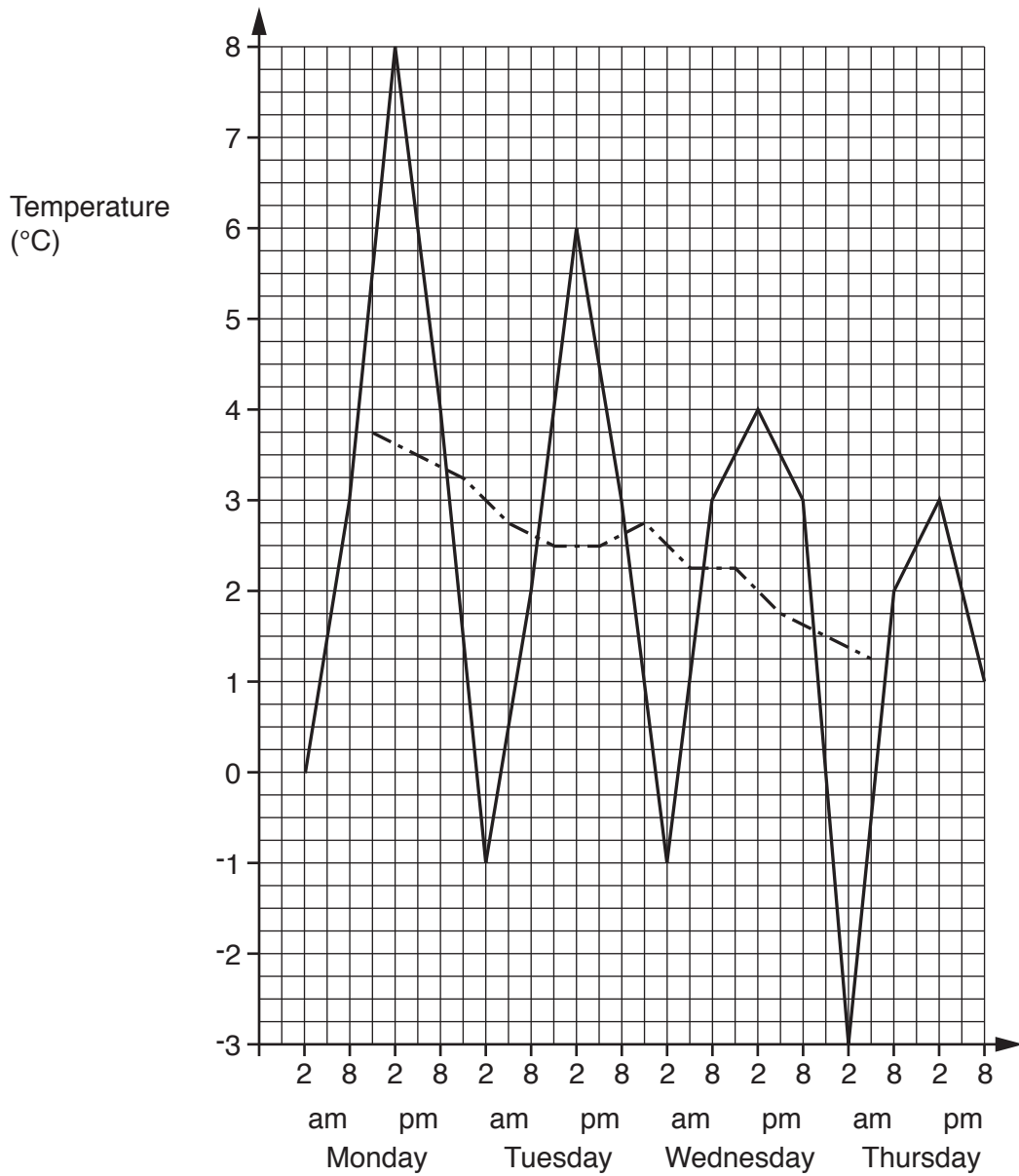

(a) Show by calculation that the first moving average, centred on Monday 11am, is 3.75 °C.

.....  
.....  
.....  
..... [1]

(b) Calculate the moving average centred on Thursday 11am.

(b) ..... °C [2]

(c) Describe how the temperatures vary within each day.

.....  
.....  
..... [1]

(d) Describe the trend in the temperatures over the four days.

.....  
.....  
..... [1]

- 13 In triangle ABC, BD is perpendicular to AC.  
AD = 2.4 cm, DC = 5.2 cm and angle BCD =  $47^\circ$ .

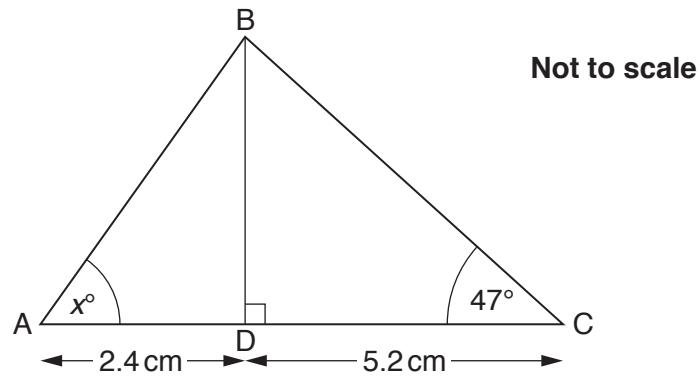

Calculate  $x$ .

.....  $^\circ$  [5]

- 14 (a) On 1st January 2015, Hilary invested some money at an interest rate of 4.3% per year. On 1st January 2016, she has a total of £4025.98.

How much did she have on 1st January 2015?

(a) £ ..... [3]

- (b) On 1st January 2014, Harry invested £5720 at a compound interest rate of 4% per year.

On 1st January of which year will his investment exceed £7000?  
Show clearly all your working.

(b) ..... [3]

15 (a) Solve.

$$\frac{8x+5}{3} = 2x-4$$

(a)  $x = \dots\dots\dots$  [3]

(b) Rearrange the equation to make  $x$  the subject.

$$y = 4x^2 - 15$$

(b)  $\dots\dots\dots$  [3]

- 16 Find the surface area of a sphere of radius 8 cm.  
Give the units of your answer.

..... [3]

- 17 Solve this equation, giving your answers correct to 2 decimal places.

$$3x^2 + 5x - 1 = 0$$

$x = \dots\dots\dots$  or  $x = \dots\dots\dots$  [4]

- 18 (a)  $y$  is directly proportional to  $x^2$ .

$x$	2	6
$y$	20	$a$

Find the value of  $a$ .

(a) ..... [2]

- (b)  $y$  is inversely proportional to  $x$  and  $y = 18$  when  $x = 4$ .

Write an equation linking  $x$  and  $y$ .

(b) ..... [3]

19 Here is the graph of  $y = \sin x$  for  $0^\circ \leq x \leq 360^\circ$ .

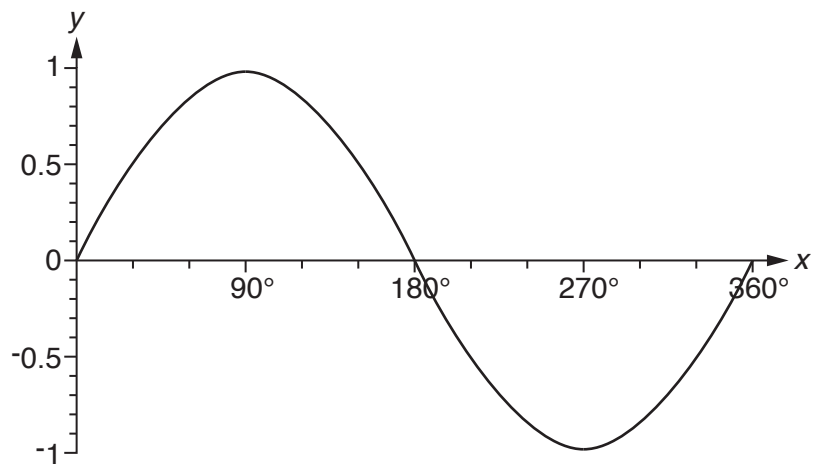

Calculate the two solutions of the equation  $\sin x = 0.82$  for values of  $x$  between  $0^\circ$  and  $360^\circ$ .

$x = \dots\dots\dots^\circ$  and  $x = \dots\dots\dots^\circ$  [2]

20 Solve.

$$y = 2x^2 + 16x - 9$$

$$y = 5x - 3$$

$$x = \dots\dots\dots y = \dots\dots\dots$$

$$x = \dots\dots\dots y = \dots\dots\dots$$

[6]

**END OF QUESTION PAPER**

**OCR**  
Oxford Cambridge and RSA

**Copyright Information**

OCR is committed to seeking permission to reproduce all third-party content that it uses in its assessment materials. OCR has attempted to identify and contact all copyright holders whose work is used in this paper. To avoid the issue of disclosure of answer-related information to candidates, all copyright acknowledgements are reproduced in the OCR Copyright Acknowledgements Booklet. This is produced for each series of examinations and is freely available to download from our public website ([www.ocr.org.uk](http://www.ocr.org.uk)) after the live examination series.

If OCR has unwittingly failed to correctly acknowledge or clear any third-party content in this assessment material, OCR will be happy to correct its mistake at the earliest possible opportunity.

For queries or further information please contact the Copyright Team, First Floor, 9 Hills Road, Cambridge CB2 1GE.

OCR is part of the Cambridge Assessment Group; Cambridge Assessment is the brand name of University of Cambridge Local Examinations Syndicate (UCLES), which is itself a department of the University of Cambridge.