

Please check the examination details below before entering your candidate information

Candidate surname

Other names

**Pearson Edexcel  
International GCSE**

Centre Number

--	--	--	--	--

Candidate Number

--	--	--	--	--

**Tuesday 7 January 2020**

Morning (Time: 2 hours)

Paper Reference **4MA1/1FR**

**Mathematics A**

**Paper 1FR  
Foundation Tier**



**You must have:**

Ruler graduated in centimetres and millimetres, protractor, compasses, pen, HB pencil, eraser, calculator. Tracing paper may be used.

Total Marks

### Instructions

- Use **black** ink or ball-point pen.
- **Fill in the boxes** at the top of this page with your name, centre number and candidate number.
- Answer **all** questions.
- Without sufficient working, correct answers may be awarded no marks.
- Answer the questions in the spaces provided  
– *there may be more space than you need.*
- **Calculators may be used.**
- You must **NOT** write anything on the formulae page.  
Anything you write on the formulae page will gain NO credit.

### Information

- The total mark for this paper is 100.
- The marks for **each** question are shown in brackets  
– *use this as a guide as to how much time to spend on each question.*

### Advice

- Read each question carefully before you start to answer it.
- Check your answers if you have time at the end.

Turn over ►

P58398A

©2020 Pearson Education Ltd.

1/1/1



Pearson

International GCSE Mathematics  
Formulae sheet – Foundation Tier

$$\text{Area of trapezium} = \frac{1}{2}(a + b)h$$

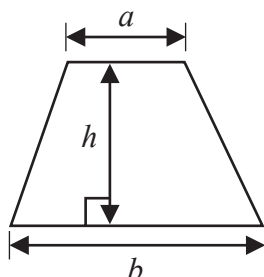

$$\text{Volume of prism} = \text{area of cross section} \times \text{length}$$

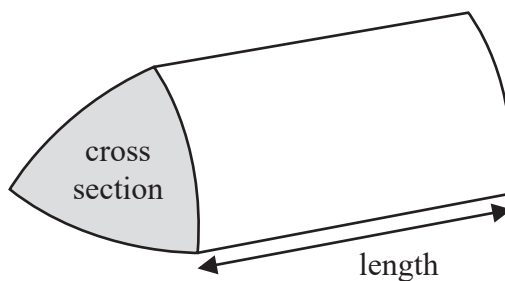

$$\text{Volume of cylinder} = \pi r^2 h$$

$$\text{Curved surface area of cylinder} = 2\pi r h$$

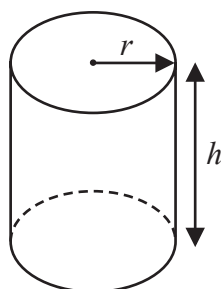

DO NOT WRITE IN THIS AREA

DO NOT WRITE IN THIS AREA

DO NOT WRITE IN THIS AREA



Answer ALL TWENTY FOUR questions.

Write your answers in the spaces provided.

You must write down all the stages in your working.

1

3	2	6	8
---	---	---	---

- (a) Write down the largest possible four digit number using all the digits that are in the box.

.....  
(1)

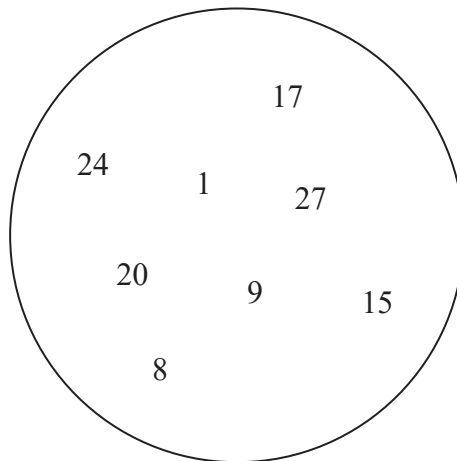

From the numbers in the circle, write down

- (b) a multiple of 6

.....  
(1)

- (c) a prime number

.....  
(1)

(Total for Question 1 is 3 marks)



- 2 At 6 pm, the temperature in Victoria's garden was  $5^{\circ}\text{C}$ .  
By midnight, the temperature in Victoria's garden had fallen by  $9^{\circ}\text{C}$ .

(a) Work out the temperature in Victoria's garden at midnight.

..... $^{\circ}\text{C}$   
(2)

Here is a list of 7 temperatures.

$4^{\circ}\text{C}$     $-6^{\circ}\text{C}$     $4^{\circ}\text{C}$     $0^{\circ}\text{C}$     $-1^{\circ}\text{C}$     $-7^{\circ}\text{C}$     $-5^{\circ}\text{C}$

(b) For the 7 temperatures in the list,

(i) write down the mode,

..... $^{\circ}\text{C}$   
(1)

(ii) find the median.

..... $^{\circ}\text{C}$   
(2)

(Total for Question 2 is 5 marks)



- 3 (a) On the grid below, draw a kite.

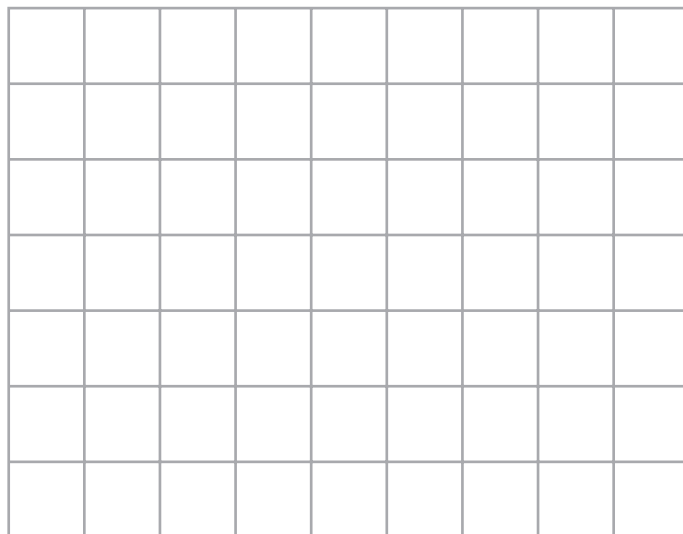

(1)

- (b) Write down the mathematical name of an 8-sided polygon.

.....  
(1)

Here is a solid prism.

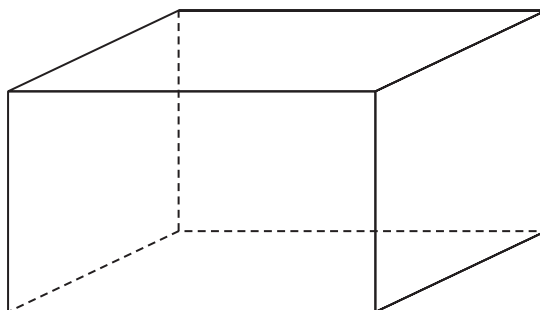

- (c) (i) Write down the mathematical name of this prism.

.....  
(2)

- (ii) How many vertices does the prism have?

(Total for Question 3 is 4 marks)



4 Mike is going to buy

1 hammer at £6

2 boxes of nails at £3.50 for each box

4 pieces of wood at £4.20 for each piece

some pairs of gloves at £1.80 for each pair

Mike has £40 to spend in total on these items.

He wants to buy as many pairs of gloves as he can.

Work out the greatest number of pairs of gloves that Mike can buy.

(Total for Question 4 is 4 marks)



- 5 The bar chart gives information about the number of points scored by each of four teachers in a quiz.

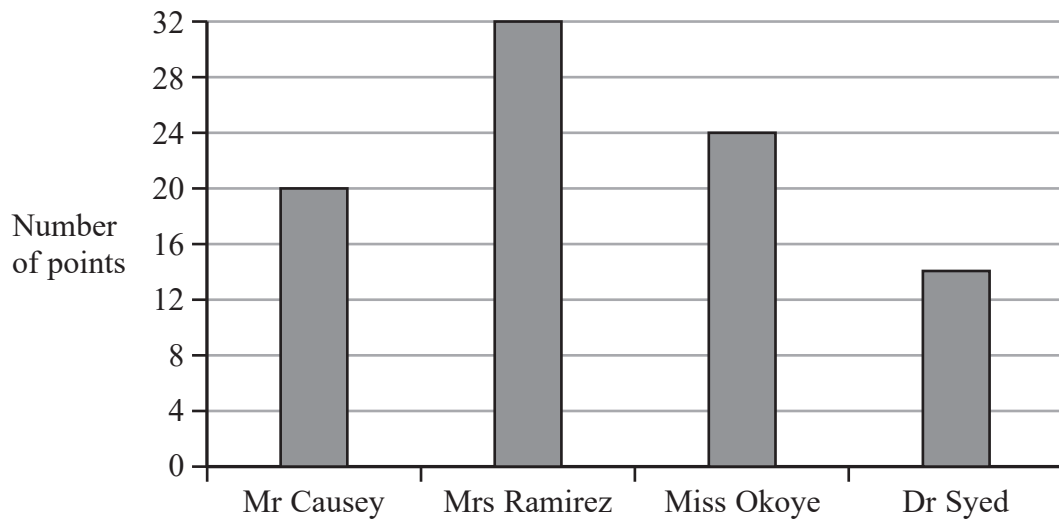

Joseph starts to draw a pictogram, shown below, for this information. The pictogram shows the number of points scored by Mr Causey and the number of points scored by Mrs Ramirez.

Mr Causey	
Mrs Ramirez	
Miss Okoye	
Dr Syed	

Key:

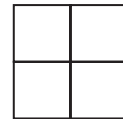

represents ..... points

Complete the pictogram, including the key.

(Total for Question 5 is 4 marks)



6 (a) Simplify  $3r \times 5t$

.....  
(1)

(b) Solve  $4x + 5 = 27$

$x =$  .....  
(2)

$$P = 7w - 5y$$

(c) Find the value of  $P$  when  $w = 2$  and  $y = 4$

$P =$  .....  
(2)

$$Q = 2u^2 - 5$$

(d) Find the value of  $Q$  when  $u = -3$

$Q =$  .....  
(2)

(Total for Question 6 is 7 marks)





7 Mohsen is going to a party.

He will choose at random one shirt from the three shirts and one pair of trousers from the three pairs of trousers in the list below.

Shirts	Trousers
Blue (B)	Green (G)
Red (R)	Orange (O)
Yellow (Y)	Purple (P)

(a) Write down all the possible combinations that Mohsen can choose.

.....

.....

.....

(2)

(b) Find the probability that Mohsen chooses the red shirt to wear to the party.

.....

(1)

There are 20 counters in a bag.

4 of the counters are pink.

9 of the counters are white.

The rest of the counters are black.

Jean takes at random one counter from the bag.

(c) Work out the probability that Jean takes a black counter.

.....

(2)

(Total for Question 7 is 5 marks)



8 Here is a rectangle.

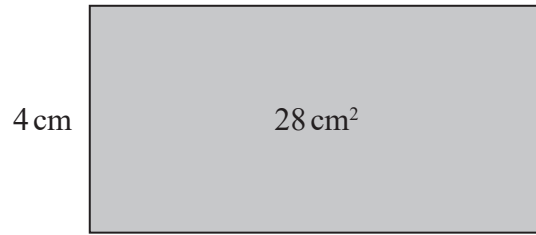

Diagram **NOT** accurately drawn

The area of the rectangle is 28 cm<sup>2</sup>

Three of these rectangles are used to make the shape below.

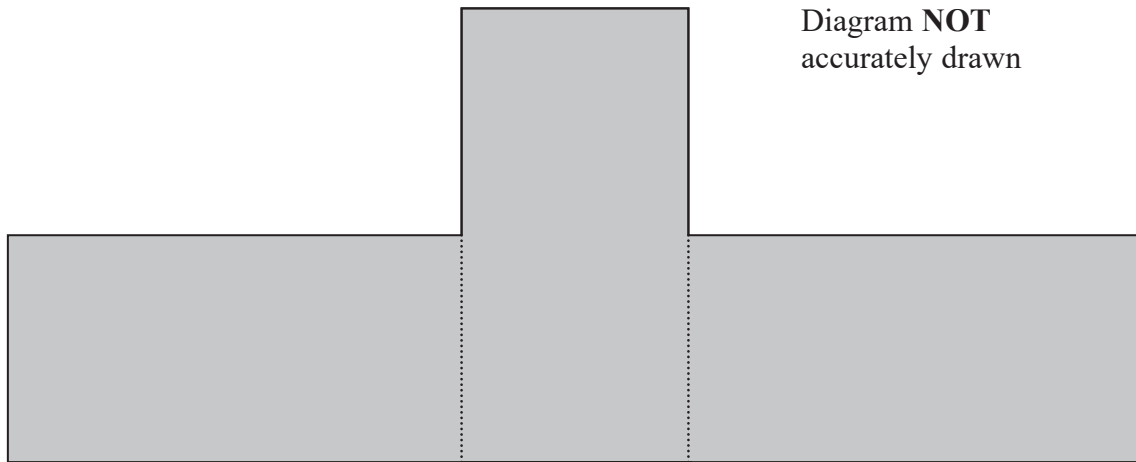

Diagram **NOT** accurately drawn

Work out the perimeter of the shape.

..... cm

(Total for Question 8 is 4 marks)

DO NOT WRITE IN THIS AREA

DO NOT WRITE IN THIS AREA

DO NOT WRITE IN THIS AREA



DO NOT WRITE IN THIS AREA

DO NOT WRITE IN THIS AREA

DO NOT WRITE IN THIS AREA

9 (a) Write 24.8635 correct to 3 significant figures.

.....  
(1)

(b) Find the value of  $\sqrt{50.41}$

.....  
(1)

(c) Change  $\frac{7}{8}$  to a percentage.

..... %  
(2)

**(Total for Question 9 is 4 marks)**



10 The accurate scale drawing shows the positions of two mobile phone masts,  $A$  and  $B$ .

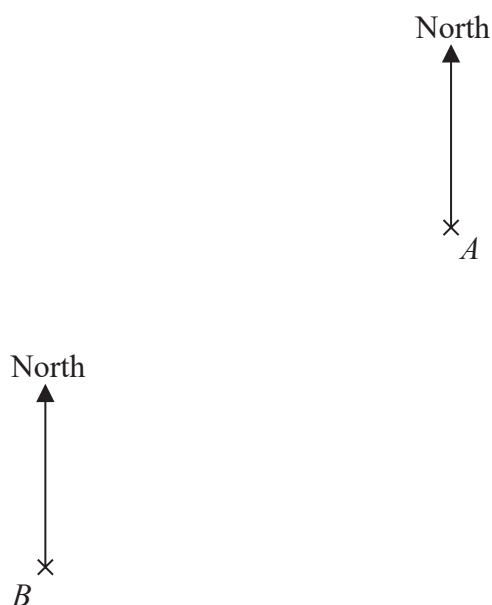

The scale is 1 cm to 2.5 km.

(a) Find the bearing of  $A$  from  $B$ .

.....<sup>o</sup>  
(1)

(b) Work out the actual distance, in km, between  $A$  and  $B$ .

..... km  
(2)

A third mobile phone mast,  $C$ , is put up.

$C$  will be on a bearing of  $115^\circ$  from  $A$ .

$C$  will be 20 km from  $B$ .

(c) Find the position of  $C$ .

Mark this point with a cross ( $\times$ ) and label it  $C$ .

(3)

(Total for Question 10 is 6 marks)



DO NOT WRITE IN THIS AREA

DO NOT WRITE IN THIS AREA

DO NOT WRITE IN THIS AREA

11 On the grid, draw the graph of  $y = 3x + 2$  for values of  $x$  from  $-2$  to  $4$

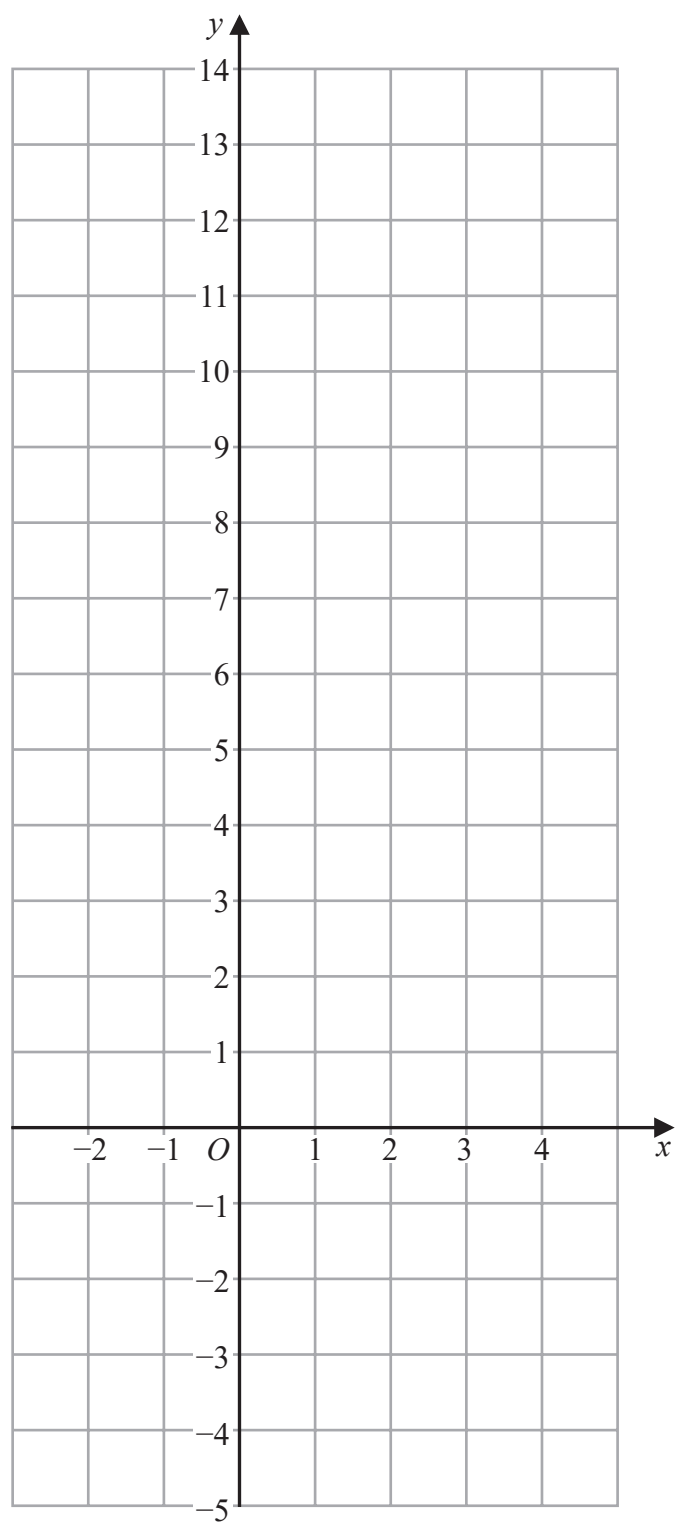

(Total for Question 11 is 3 marks)



12 Greg bought 36 oranges.  
He paid 50p for each orange.

Greg sold  $\frac{1}{2}$  of the oranges for 60p each.

He sold  $\frac{1}{3}$  of the oranges for 40p each.

He sold the remainder of the oranges for 25p each.

Work out Greg's percentage loss.

.....%

(Total for Question 12 is 5 marks)

DO NOT WRITE IN THIS AREA

DO NOT WRITE IN THIS AREA

DO NOT WRITE IN THIS AREA



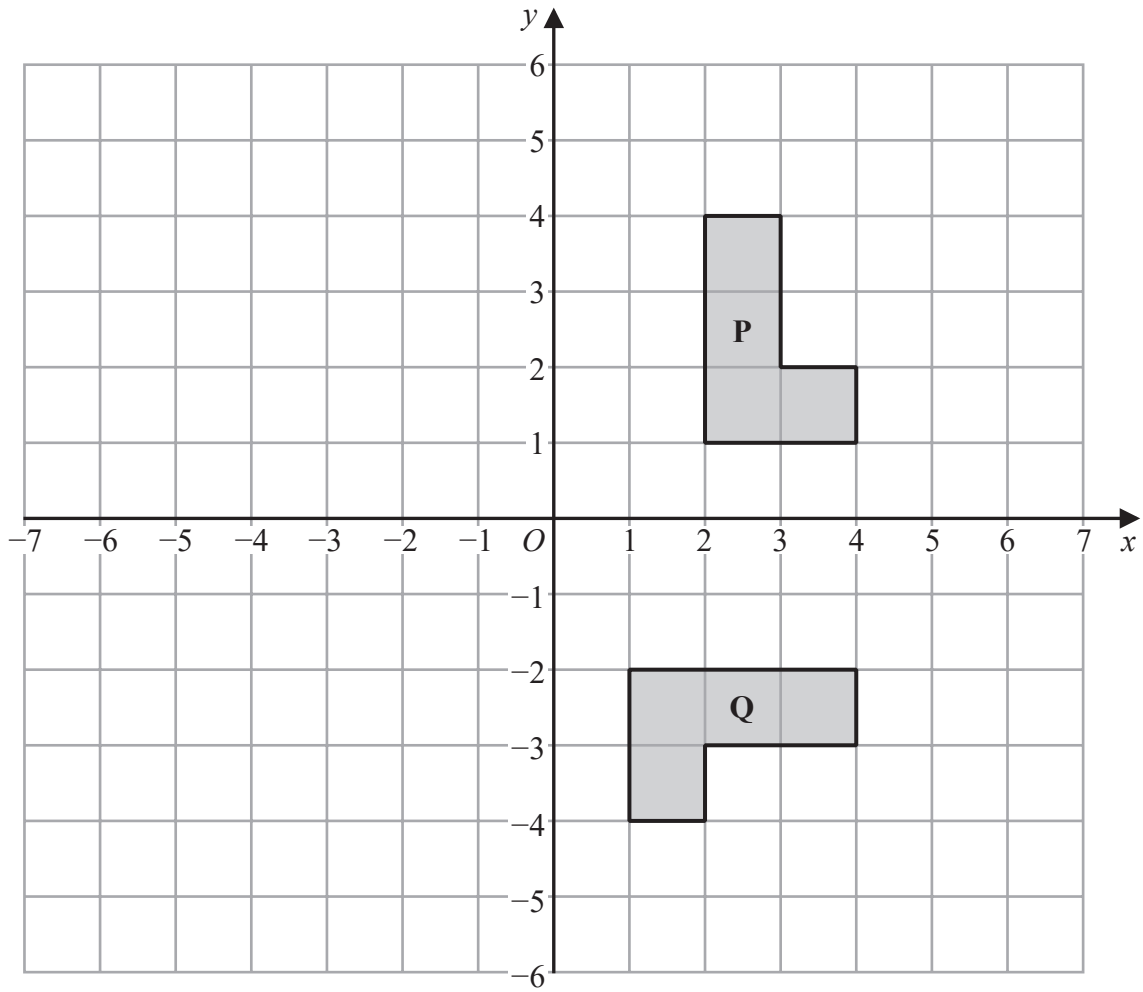

(a) Describe fully the single transformation that maps shape **P** onto shape **Q**.

(3)

(b) On the grid, reflect shape **P** in the line  $x = -1$   
Label the new shape **R**.

(2)

(Total for Question 13 is 5 marks)

DO NOT WRITE IN THIS AREA

DO NOT WRITE IN THIS AREA

DO NOT WRITE IN THIS AREA



- 14 Brendon, Asha and Julie share some money in the ratios 3 : 2 : 6  
The **total** amount of money that Asha and Julie receive is \$36

Work out the amount of money that Brendon receives.

\$.....

(Total for Question 14 is 3 marks)

15 Show that  $3\frac{1}{5} \times 2\frac{5}{8} = 8\frac{2}{5}$

(Total for Question 15 is 3 marks)

DO NOT WRITE IN THIS AREA

DO NOT WRITE IN THIS AREA

DO NOT WRITE IN THIS AREA





16 (a) Make  $a$  the subject of  $d = g + 2ac$

.....  
(2)

(b) Factorise fully  $9ef - 12f$

.....  
(2)

(c) Expand and simplify  $(x + 2)(x - 5)$

.....  
(2)

(d) Simplify fully  $\frac{n^4 \times n^7}{n^5}$

.....  
(2)

(Total for Question 16 is 8 marks)



17  $B = \{b, l, u, e\}$

$$G = \{g, r, e, y\}$$

$$W = \{w, h, i, t, e\}$$

(a) List all the members of the set

(i)  $B \cup G$

(ii)  $W \cap G'$

(2)

Serena writes down the statement  $B \cap G \cap W = \emptyset$

(b) Is Serena's statement correct?

You must give a reason for your answer.

(1)

(Total for Question 17 is 3 marks)



DO NOT WRITE IN THIS AREA

DO NOT WRITE IN THIS AREA

DO NOT WRITE IN THIS AREA

18 The diagram shows Yuen's garden.

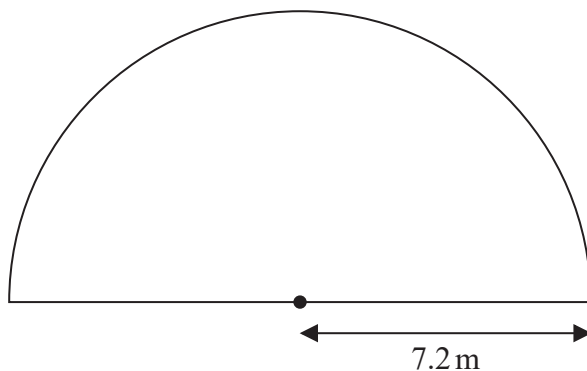

Diagram **NOT** accurately drawn

The garden is in the shape of a semicircle of radius 7.2 m.  
Yuen is going to cover his garden with grass seed.

Yuen has 12 boxes of grass seed.  
Each box of grass seed contains enough seed to cover  $6 \text{ m}^2$  of the garden.

Has Yuen enough grass seed for his garden?  
Show your working clearly.

(Total for Question 18 is 3 marks)



19 The weight of a cat is 4.3 kg correct to 2 significant figures.

(a) Write down the upper bound of the weight of the cat.

..... kg  
(1)

(b) Write down the lower bound of the weight of the cat.

..... kg  
(1)

(Total for Question 19 is 2 marks)

20 Solve  $x^2 - 5x - 36 = 0$

Show clear algebraic working.

.....

(Total for Question 20 is 3 marks)



DO NOT WRITE IN THIS AREA

DO NOT WRITE IN THIS AREA

DO NOT WRITE IN THIS AREA

21 In a sale, the normal price of a hat is reduced by 15%  
The sale price of the hat is 20.40 euros.

Work out the normal price of the hat.

..... euros

**(Total for Question 21 is 3 marks)**



22 5 children are playing on a trampoline.  
The mean weight of the 5 children is 28 kg.

2 of the children get off the trampoline.  
The mean weight of these 2 children is 26.5 kg.

Work out the mean weight of the 3 children who remain on the trampoline.

..... kg

**(Total for Question 22 is 3 marks)**

DO NOT WRITE IN THIS AREA

DO NOT WRITE IN THIS AREA

DO NOT WRITE IN THIS AREA



DO NOT WRITE IN THIS AREA

DO NOT WRITE IN THIS AREA

DO NOT WRITE IN THIS AREA

23 Pablo made a solid gold statue.

He melted down some gold blocks and used the gold to make the statue.  
Each block of gold was a cuboid, as shown below.

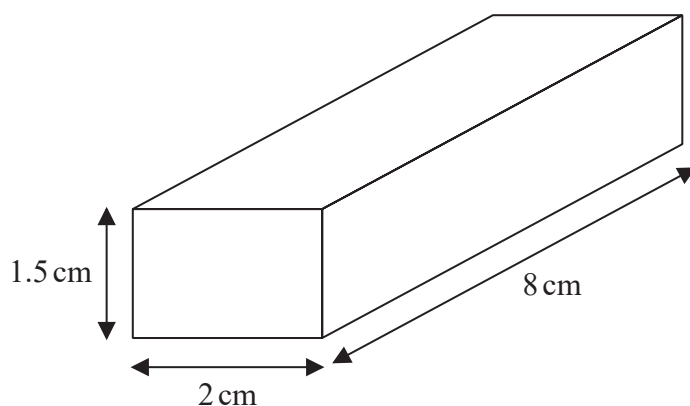

Diagram **NOT** accurately drawn

The mass of the statue is 5.73 kg.  
The density of gold is  $19.32 \text{ g/cm}^3$

Work out the least number of gold blocks Pablo melted down in order to make the statue.  
Show your working clearly.

.....  
(Total for Question 23 is 5 marks)



24 The diagram shows a regular hexagon,  $ABCDEF$ , and an isosceles triangle,  $GHI$ .

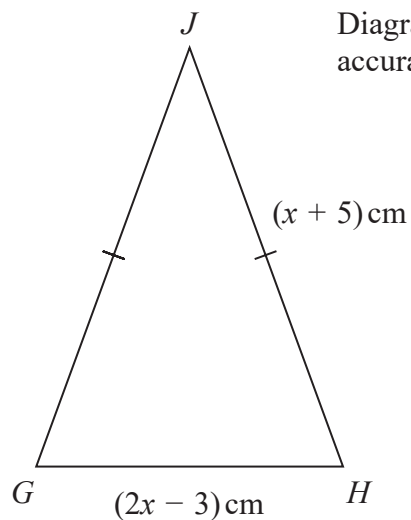
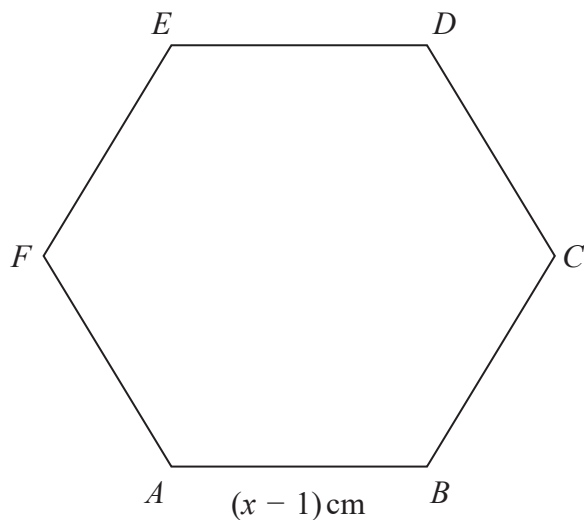

Diagram **NOT** accurately drawn

The perimeter of the hexagon is equal to the perimeter of the triangle.

Find the length of each side of the hexagon.  
Show clear algebraic working.

..... cm

(Total for Question 24 is 5 marks)

**TOTAL FOR PAPER IS 100 MARKS**

DO NOT WRITE IN THIS AREA

DO NOT WRITE IN THIS AREA

DO NOT WRITE IN THIS AREA

