

Write your name here

Surname

Other names

Centre Number

Candidate Number

Edexcel GCSE

Mathematics B

**Unit 2: Number, Algebra, Geometry 1
(Non-Calculator)**

Higher Tier

Monday 4 March 2013 – Morning

Time: 1 hour 15 minutes

Paper Reference

5MB2H/01

You must have: Ruler graduated in centimetres and millimetres, protractor, pair of compasses, pen, HB pencil, eraser. Tracing paper may be used.

Total Marks

Instructions

- Use **black** ink or ball-point pen.
- **Fill in the boxes** at the top of this page with your name, centre number and candidate number.
- Answer **all** questions.
- Answer the questions in the spaces provided – *there may be more space than you need.*
- **Calculators must not be used.**



Information

- The total mark for this paper is 60
- The marks for **each** question are shown in brackets – *use this as a guide as to how much time to spend on each question.*
- Questions labelled with an **asterisk** (*) are ones where the quality of your written communication will be assessed.

Advice

- Read each question carefully before you start to answer it.
- Keep an eye on the time.
- Try to answer every question.
- Check your answers if you have time at the end.

Turn over ►

P42053A

©2013 Pearson Education Ltd.

6/6/8/5/3/



PEARSON

GCSE Mathematics 2MB01

Formulae: Higher Tier

**You must not write on this formulae page.
Anything you write on this formulae page will gain NO credit.**

Volume of prism = area of cross section \times length

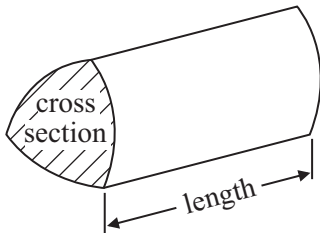

Area of trapezium = $\frac{1}{2} (a + b)h$

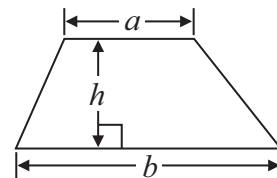

Volume of sphere = $\frac{4}{3} \pi r^3$

Surface area of sphere = $4\pi r^2$

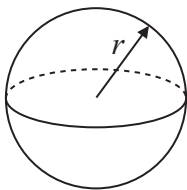

Volume of cone = $\frac{1}{3} \pi r^2 h$

Curved surface area of cone = $\pi r l$

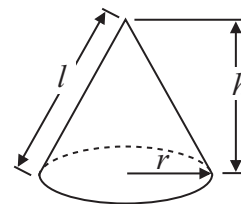

In any triangle ABC

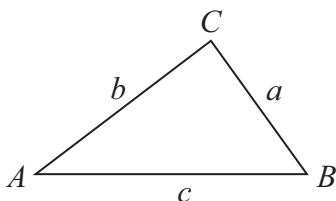

The Quadratic Equation

The solutions of $ax^2 + bx + c = 0$
where $a \neq 0$, are given by

$$x = \frac{-b \pm \sqrt{b^2 - 4ac}}{2a}$$

Sine Rule $\frac{a}{\sin A} = \frac{b}{\sin B} = \frac{c}{\sin C}$

Cosine Rule $a^2 = b^2 + c^2 - 2bc \cos A$

Area of triangle = $\frac{1}{2} ab \sin C$



Answer ALL questions.

Write your answers in the spaces provided.

You must write down all stages in your working.

You must NOT use a calculator.

1 (a) Complete the table of values for $y = 2x + 2$

x	-2	-1	0	1	2	3	4
y	-2				6		

(2)

(b) On the grid, draw the graph of $y = 2x + 2$

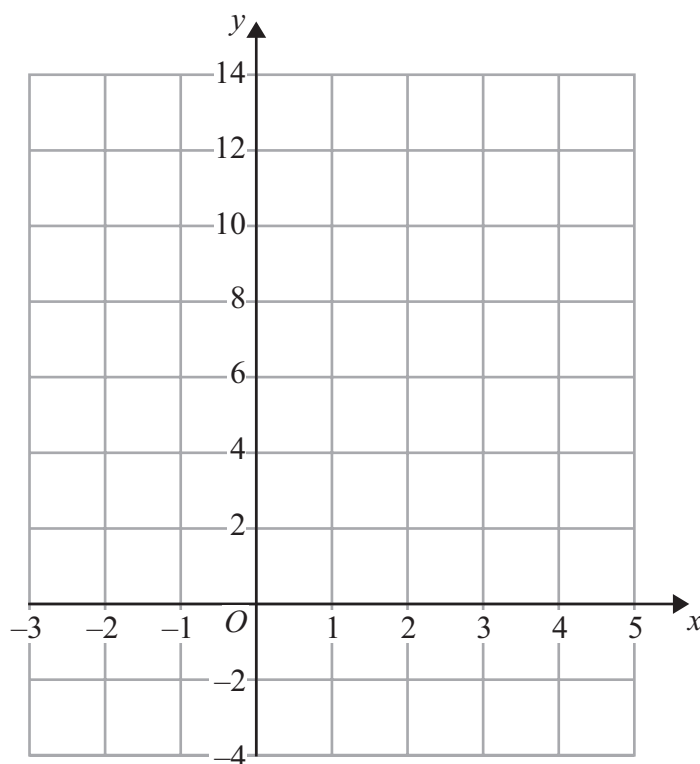

(2)

(Total for Question 1 is 4 marks)



- 2 Grant drives a lorry to deliver some equipment from a factory to a hospital.
The distance from the factory to the hospital is 200 miles.

The lorry uses one litre of fuel to go 5 miles.
A litre of fuel for the lorry costs £1.50

Work out the total cost of the fuel the lorry used.

£.....

(Total for Question 2 is 3 marks)

- 3 Work out $\frac{3}{8} + \frac{1}{3}$

.....

(Total for Question 3 is 2 marks)



4 Here is a diagram of part of a wall in Sarah's house.

Diagram **NOT**
accurately drawn

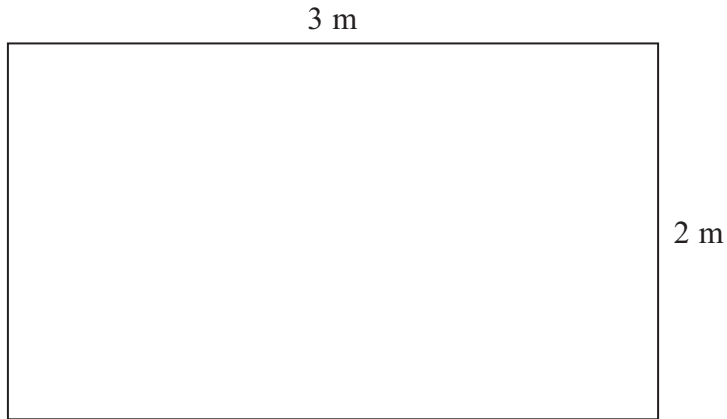

Sarah is going to cover this part of the wall with square tiles.
The square tiles have sides of 20 cm.

Work out the number of tiles Sarah needs.

..... tiles

(Total for Question 4 is 3 marks)



5 (a) Simplify $4x + 3y - x - 4y$

.....
(2)

(b) Simplify $2 + 4x - 7x$

.....
(1)

(c) Simplify $t^4 \times t^7$

.....
(1)

(d) Simplify $y^6 \div y^2$

.....
(1)

(e) Simplify $(c^3)^4$

.....
(1)

(Total for Question 5 is 6 marks)



6 Bill gives away £20000 to help animals.

He gives 20% of the £20000 to a donkey sanctuary.

He shares the rest of the £20000 between a dogs' home and a cats' home in the ratio 3 : 2

How much money does Bill give to the cats' home?

£.....

(Total for Question 6 is 4 marks)



7 The first five terms of an arithmetic sequence are

2 6 10 14 18

(a) Write down an expression, in terms of n , for the n th term of this sequence.

.....
(2)

An expression for the n th term of a different sequence is $20 - 5n$

(b) Work out the 10th term of this sequence.

.....
(2)

(Total for Question 7 is 4 marks)



8

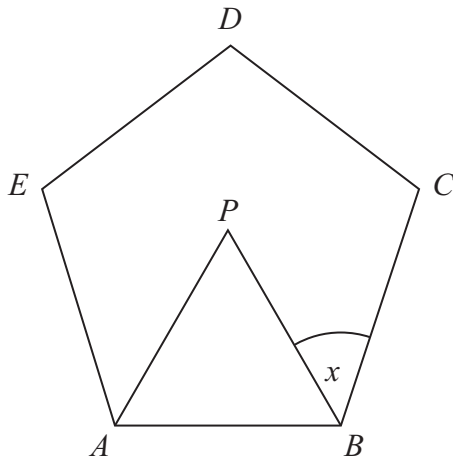

Diagram **NOT**
accurately drawn

$ABCDE$ is a regular pentagon.
 ABP is an equilateral triangle.

Work out the size of angle x .

.....
(Total for Question 8 is 4 marks)



9 (a) Factorise $3t + 12$

.....
(1)

(b) (i) Expand and simplify $7(2x + 1) + 6(x + 3)$

.....
(ii) Show that when x is a whole number

$$7(2x + 1) + 6(x + 3)$$

is always a multiple of 5

(3)

(Total for Question 9 is 4 marks)



10 Here is a solid prism.

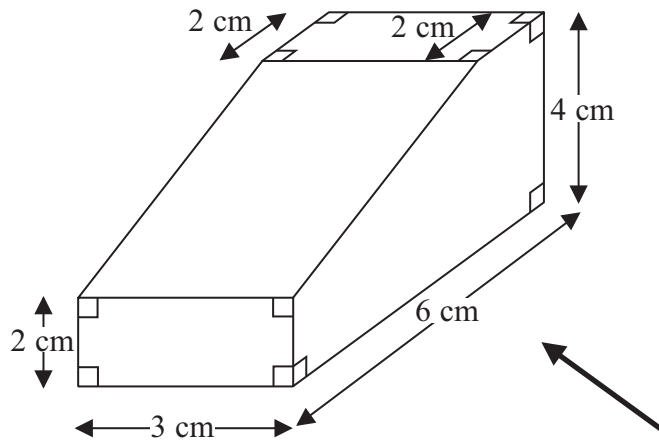
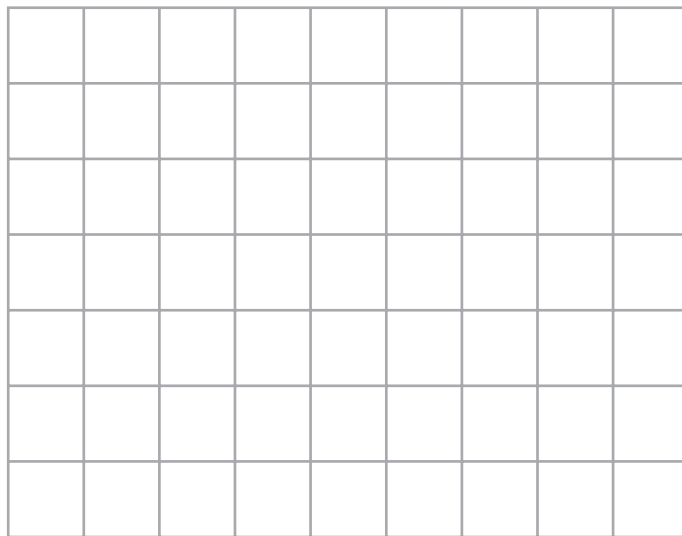

Diagram **NOT** accurately drawn

On the grid, draw an accurate side elevation of the solid prism from the direction of the arrow.



(Total for Question 10 is 2 marks)



11 The diagram represents a shed.

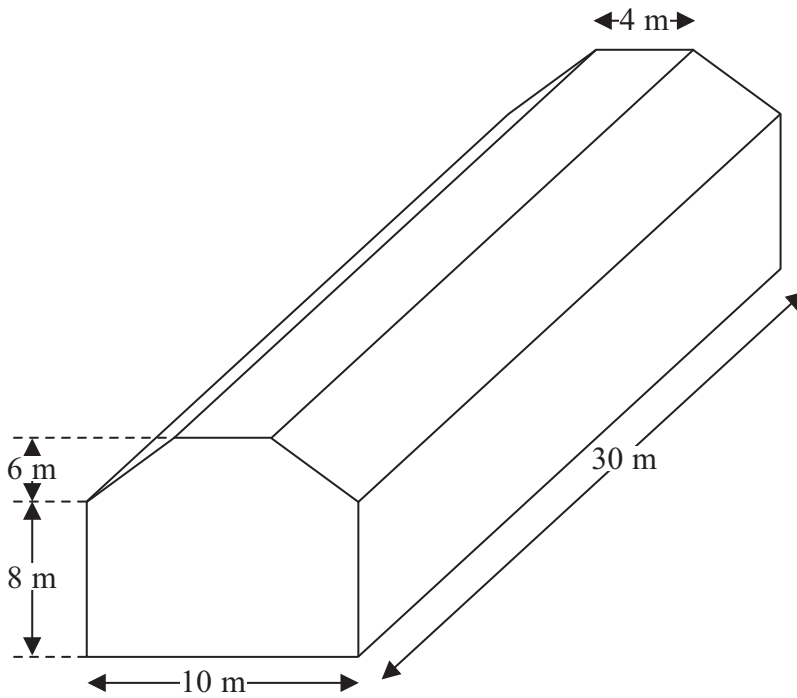

Diagram **NOT** accurately drawn

The shed is in the shape of a prism.
The cross section of the prism is a hexagon.
The hexagon has one line of symmetry.
The walls of the shed are vertical.

Calculate the volume of the shed.

..... m³

(Total for Question 11 is 4 marks)



- 12 Write these numbers in order of size.
Start with the smallest number.

$$4.2 \times 10^5 \quad 13 \times 10^4 \quad 30 \times 10^{-6} \quad -2.5 \times 10^{-4} \quad 0.0052 \times 10^6$$

(Total for Question 12 is 3 marks)

13

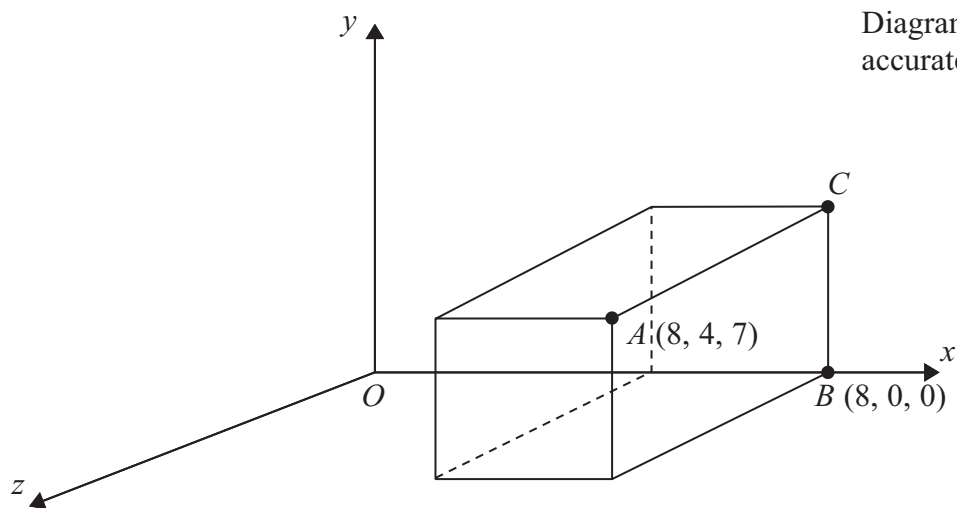

Diagram NOT
accurately drawn

A , B and C are 3 corners of a cuboid.

- (a) Write down the coordinates of C .

(.....,,)
(1)

M is the midpoint of the line AB .

- (b) Find the coordinates of M .

(.....,,)
(2)

(Total for Question 13 is 3 marks)



*14

Diagram **NOT**
accurately drawn

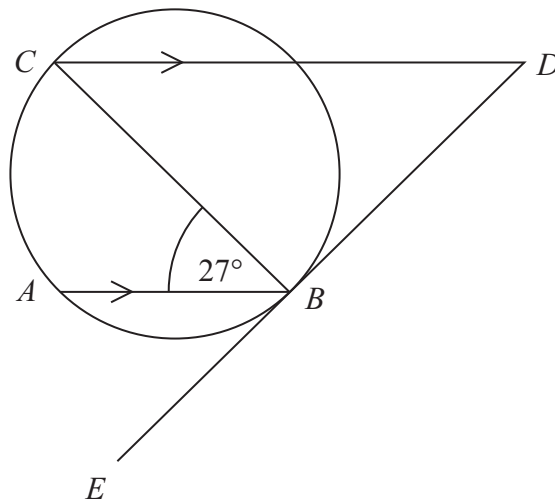

A, B and *C* are three points on a circle.
DBE is a tangent to the circle.
AB is parallel to *CD*.
BC is a diameter.
Angle $ABC = 27^\circ$.

Find the size of angle CDB .
Give reasons for your answer.

(Total for Question 14 is 4 marks)



15 The straight line **L** has equation $y = 3x - 4$

(a) Write down an equation of the line parallel to **L** which passes through the origin.

.....
(2)

(b) Find an equation of the straight line that passes through (0, 5) and is perpendicular to **L**.

.....
(2)

(Total for Question 15 is 4 marks)

Turn over for Questions 16 and 17



16 Work out the value of $\frac{\sqrt{5} + 1}{2} \times \frac{\sqrt{5} - 1}{2}$

Give your answer in its simplest form.

.....
(Total for Question 16 is 3 marks)

17 Simplify $\frac{x^2 - 3x}{2x^2 - 5x - 3}$

.....
(Total for Question 17 is 3 marks)

TOTAL FOR PAPER IS 60 MARKS

