

Please write clearly in block capitals.

Centre number

--	--	--	--	--

Candidate number

--	--	--	--

Surname

Forename(s)

Candidate signature

GCSE MATHEMATICS

H

Higher Tier Unit 3 Geometry and Algebra

Tuesday 8 November 2016

Morning

Time allowed: 1 hour 30 minutes

Materials

For this paper you must have:

- a calculator
- mathematical instruments.



Instructions

- Use black ink or black ball-point pen. Draw diagrams in pencil.
- Answer **all** questions.
- You must answer the questions in the spaces provided. Do not write outside the box around each page or on blank pages.
- Do all rough work in this book. Cross through any work that you do not want to be marked.
- If your calculator does not have a π button, take the value of π to be 3.14 unless another value is given in the question.

Information

- The marks for questions are shown in brackets.
- The maximum mark for this paper is 80.
- Quality of written communication is specifically assessed in Questions 1 and 5. These questions are indicated with an asterisk (*).
- You may ask for more answer paper, graph paper and tracing paper. These must be tagged securely to this answer book.

Advice

- In all calculations, show clearly how you work out your answer.



Formulae Sheet: Higher Tier

Area of trapezium = $\frac{1}{2}(a+b)h$

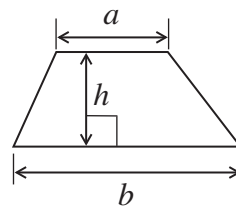

Volume of prism = area of cross-section \times length

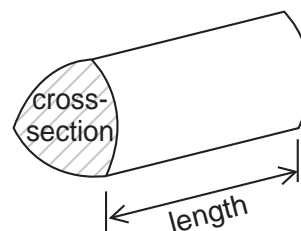

Volume of sphere = $\frac{4}{3}\pi r^3$

Surface area of sphere = $4\pi r^2$

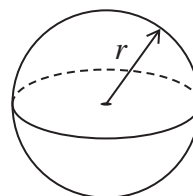

Volume of cone = $\frac{1}{3}\pi r^2 h$

Curved surface area of cone = $\pi r l$

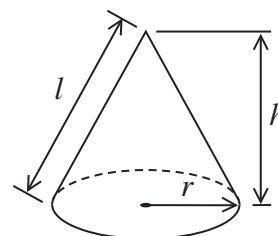

In any triangle ABC

Area of triangle = $\frac{1}{2}ab \sin C$

Sine rule $\frac{a}{\sin A} = \frac{b}{\sin B} = \frac{c}{\sin C}$

Cosine rule $a^2 = b^2 + c^2 - 2bc \cos A$

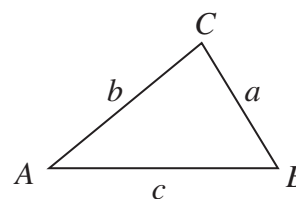

The Quadratic Equation

The solutions of $ax^2 + bx + c = 0$, where $a \neq 0$, are given by

$$x = \frac{-b \pm \sqrt{b^2 - 4ac}}{2a}$$



Answer **all** questions in the spaces provided.

***1** The same type of shirt is sold in two shops.

Shop A



£19.90

Buy one
get second for half price

Shop B



£18

Get a 15% discount
when you buy two

Which shop is cheaper for buying **two** of these shirts?
You **must** show your working.

[5 marks]

Answer _____

5

Turn over ►



2 (a)

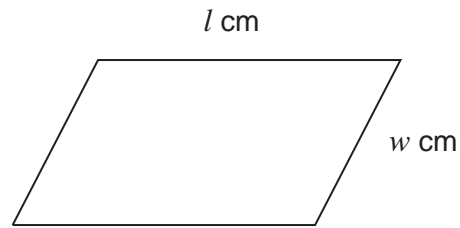

The perimeter of the parallelogram is P cm

Circle the correct formula.

[1 mark]

$P = l + w$

$P = lw$

$P = 2(l + w)$

$P = 2lw$

2 (b)

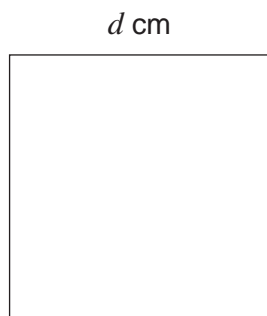

The area of the square is A cm²

Circle the correct formula.

[1 mark]

$A = 2d$

$A = 4d$

$A = \sqrt{d}$

$A = d^2$



2 (c)

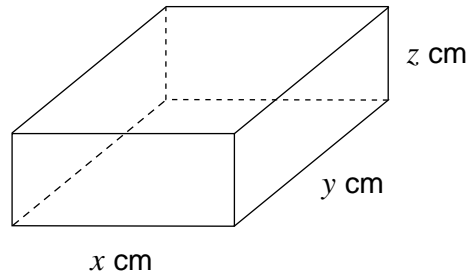

The surface area of the cuboid is $S \text{ cm}^2$

Circle the correct formula.

[1 mark]

$$S = xyz$$

$$S = (xyz)^2$$

$$S = 6xyz$$

$$S = 2(xy + xz + yz)$$

2 (d) The surface area of a **cube** is 150 cm^2

Work out the volume of the cube.

[4 marks]

Answer _____ cm^3



- 3 (a)** The radius of this circle is 2.5 cm

Not drawn accurately

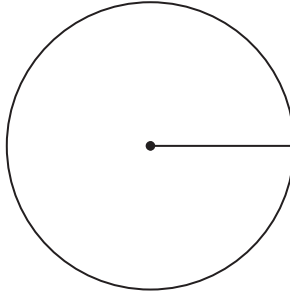

Work out the area.
Give your answer to 1 significant figure.

[3 marks]

Answer _____ cm^2

- 3 (b)** The diameter of this semicircle is 16 cm

Not drawn accurately

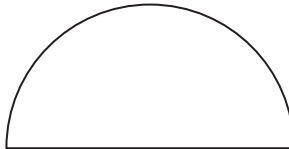

Work out the perimeter of the semicircle.

[3 marks]

Answer _____ cm



4 (a) Describe fully the **single** transformation that maps shape P to shape Q .

[3 marks]

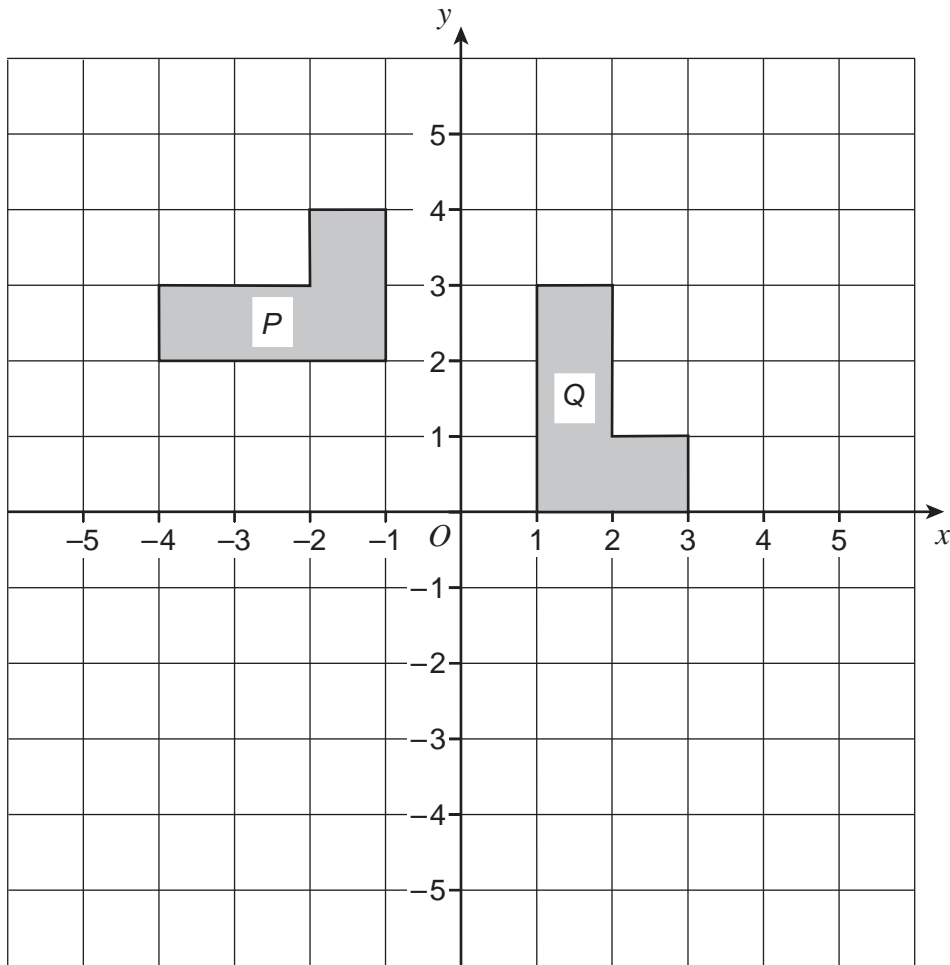

4 (b) On the grid, translate shape Q by vector $\begin{pmatrix} 1 \\ -5 \end{pmatrix}$

[2 marks]



*5

Use trial and improvement to find a positive solution to $x^3 - 10x = 6$
Give your answer to 1 decimal place.

[4 marks]

x	$x^3 - 10x$	Comment
4	24	Too big

$x =$ _____



6 Ali is going to drive 210 miles.
He has 27 **litres** of petrol in his car.
His car travels 36 miles for each **gallon** of petrol.

Does he have enough petrol for the journey?
You **must** show your working.

[4 marks]

Answer _____

Turn over for the next question

8

Turn over ►



- 7 The diagram shows two regular hexagons with the base lines extended.

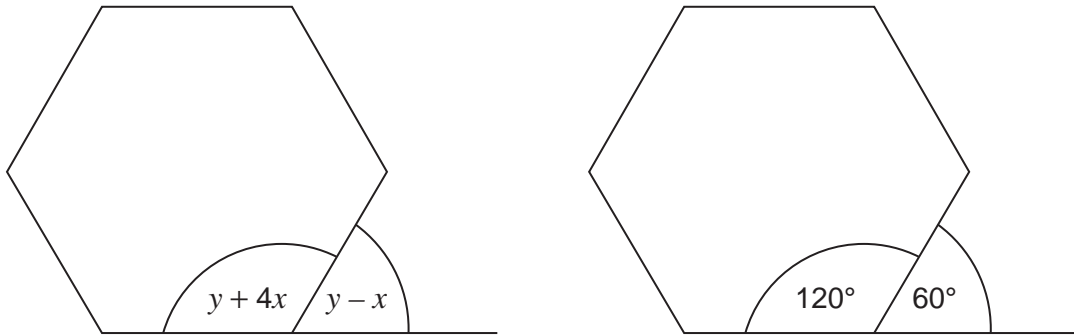

Work out the values of x and y .

[5 marks]

$x =$ _____ degrees

$y =$ _____ degrees



- 8 ABC and DEC are similar triangles.

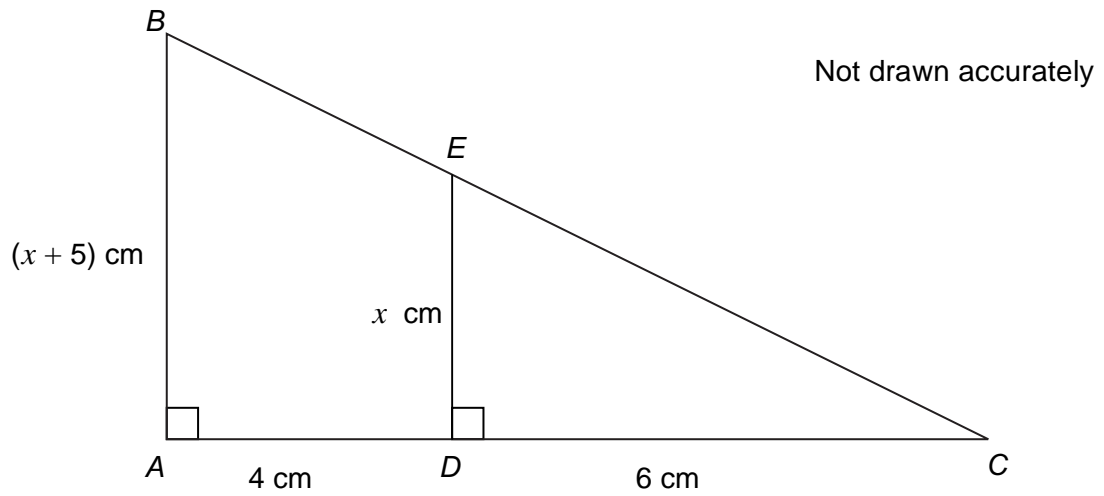

Work out the value of x .

[4 marks]

Answer _____ cm



9 $ABCD$ is a square.

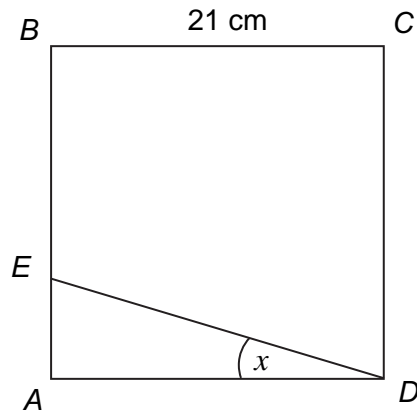

Not drawn accurately

$$AE = \frac{2}{5} EB$$

Work out the size of angle x .

[4 marks]

Answer _____ degrees



10 (a)

Not drawn accurately

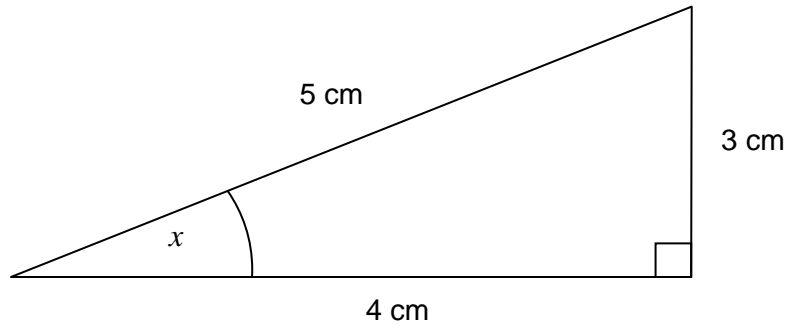
Circle the value of $\sin x$.

[1 mark]

$\frac{3}{5}$

$\frac{3}{4}$

$\frac{4}{5}$

$\frac{4}{3}$

$\frac{5}{3}$

10 (b)

Not drawn accurately

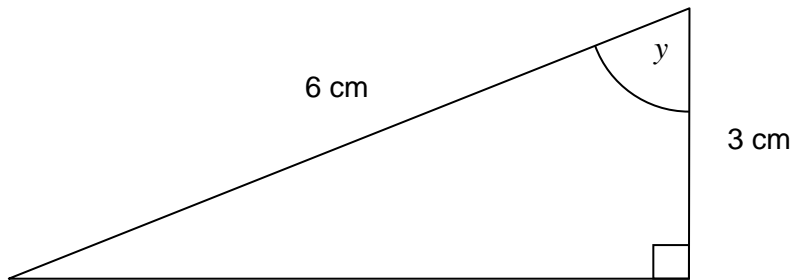
Circle the size of angle y .

[1 mark]

30°

36°

45°

50°

60°



11 (a) E, F and G are points on a circle, centre O .

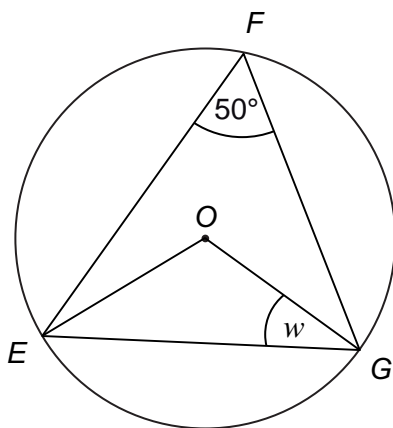

Not drawn accurately

Work out the size of angle w .

[2 marks]

Answer _____ degrees

11 (b) A, B, C and D are points on the circumference of the circle.

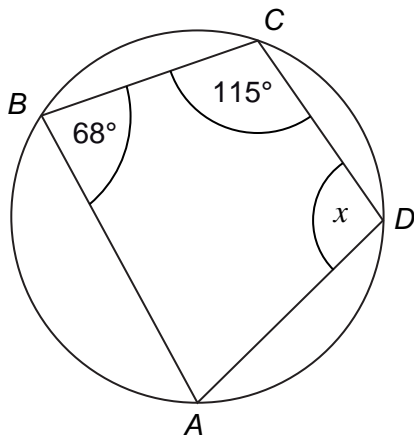

Not drawn accurately

Work out the size of angle x .
Give a reason for your answer.

[2 marks]

Answer _____ degrees

Reason _____



- 11 (c) PTQ is a tangent to the circle.
 R , S and T are points on the circle.

Not drawn accurately

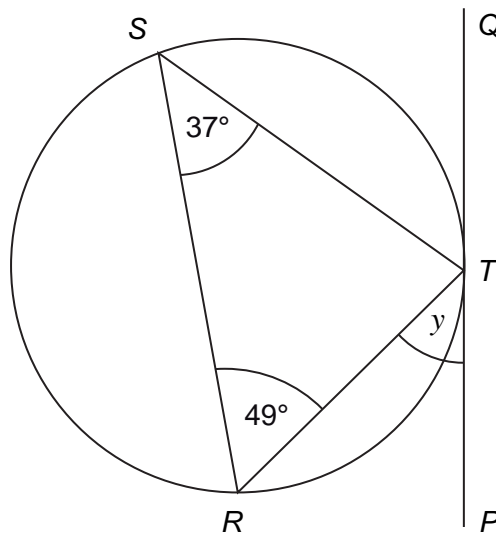

Write down the size of angle y .
Give a reason for your answer.

[2 marks]

Answer _____ degrees

Reason _____

Turn over for the next question



12 Work out length y .

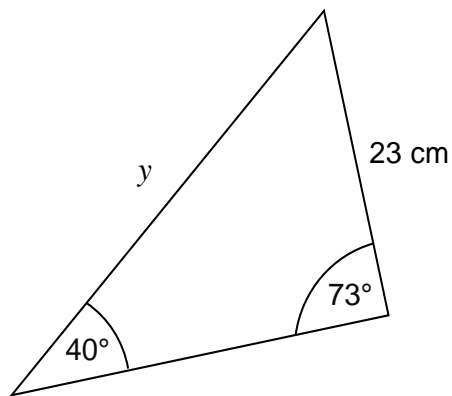

Not drawn
accurately

[3 marks]

Answer _____ cm



- 13 Work out the area of the triangle.

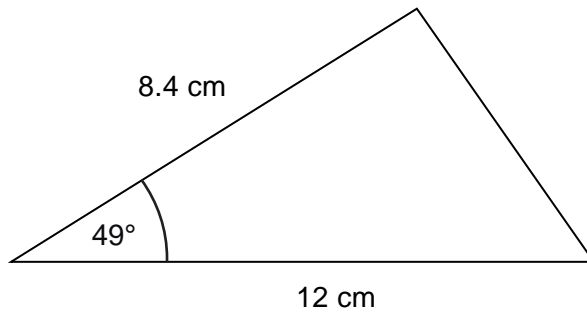

Not drawn accurately

[2 marks]

Answer _____ cm²

- 14 Solve $2x^2 + 3x - 6 = 0$

Give your answers to 2 decimal places.

[3 marks]

Answer _____ and _____



15 The area of this rectangle is 28 cm^2

Not drawn accurately

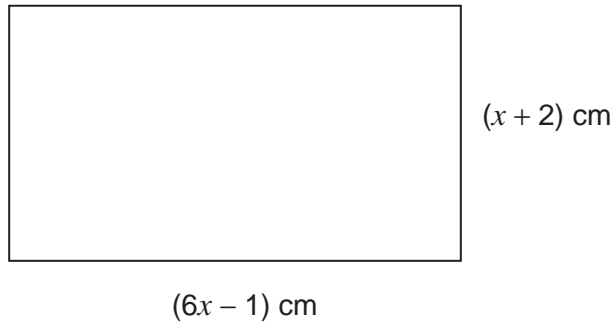

Work out the perimeter of the rectangle.

[7 marks]

Answer _____ cm

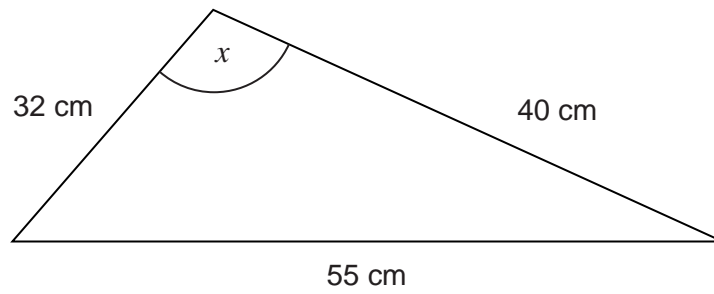

16

Work out the size of angle x .Not drawn
accurately**[3 marks]**

Answer _____ degrees

Turn over for the next question

- 17 The graph of $y = \sin x$ for $0^\circ \leq x \leq 360^\circ$ is shown.

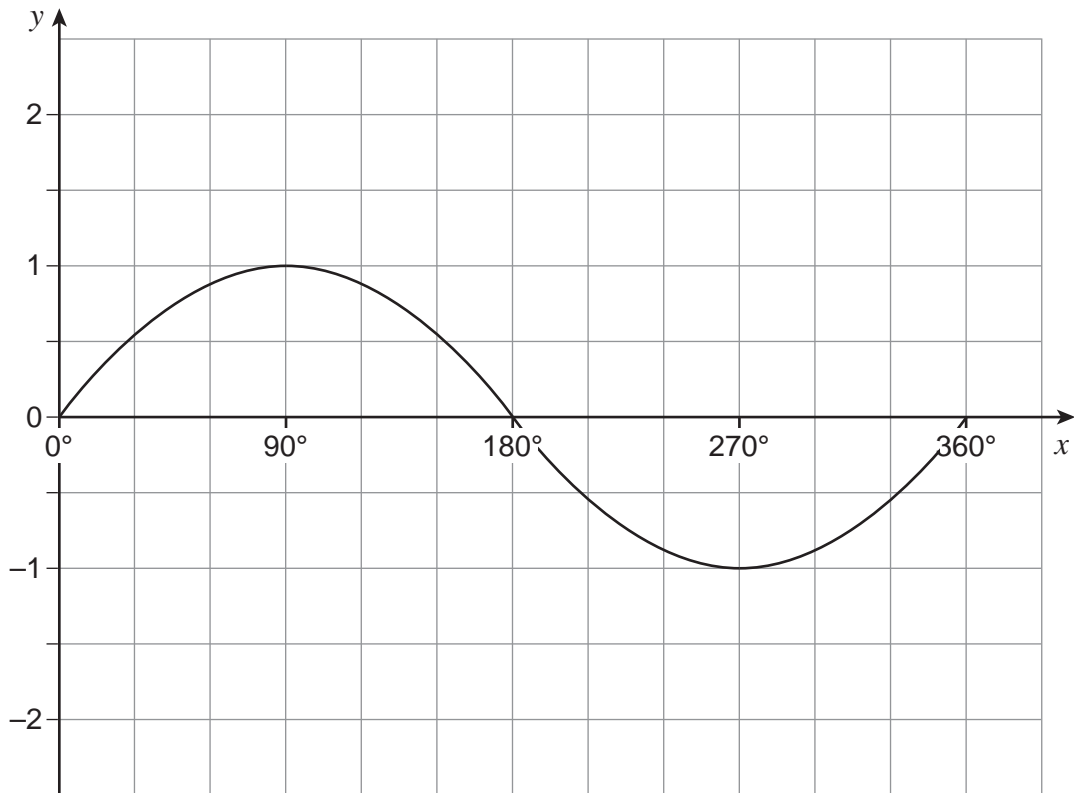

- 17 (a) On the grid below, draw the graph of $y = 1 + \sin x$ for $0^\circ \leq x \leq 360^\circ$

The graph of $y = \sin x$ is shown to help you.

[1 mark]

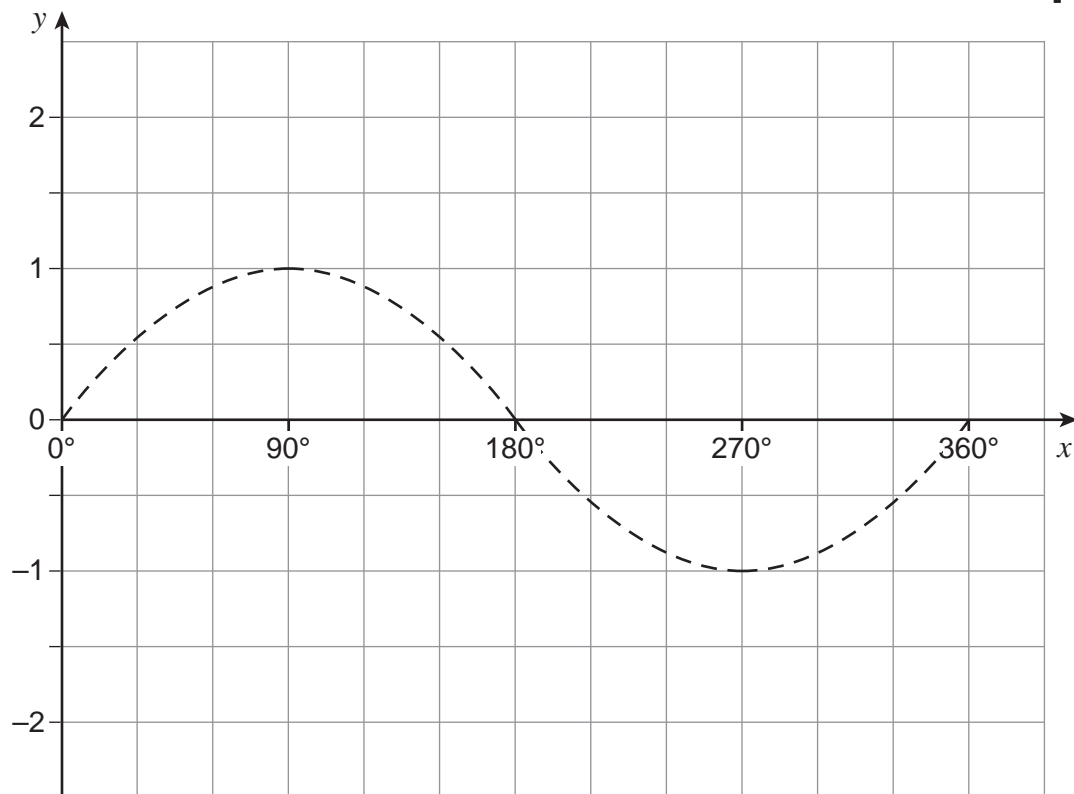

17 (b) On the grid below, draw the graph of $y = \sin(x + 90^\circ)$ for $0^\circ \leq x \leq 360^\circ$

The graph of $y = \sin x$ is shown to help you.

[1 mark]

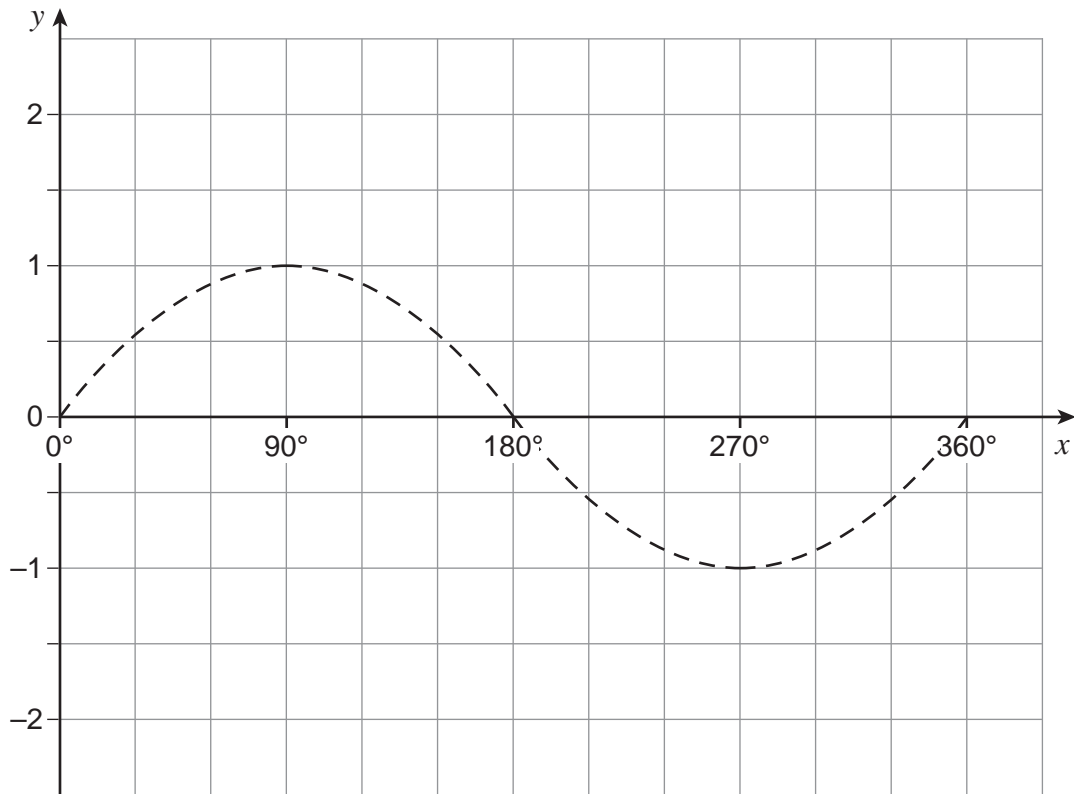

Turn over for the next question



18

C is the midpoint of AB.

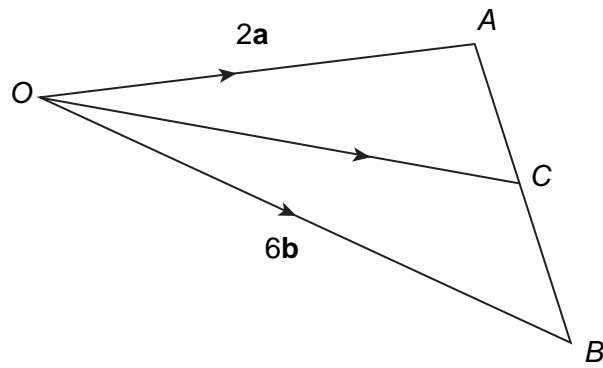

$$\vec{OA} = 2\mathbf{a}$$

$$\vec{OB} = 6\mathbf{b}$$

Work out \vec{OC} in terms of \mathbf{a} and \mathbf{b} .
Simplify your answer as far as possible.

[4 marks]

Answer _____



- 19 A hemisphere and a cone each have radius 9 cm
They are joined together to make a toy.

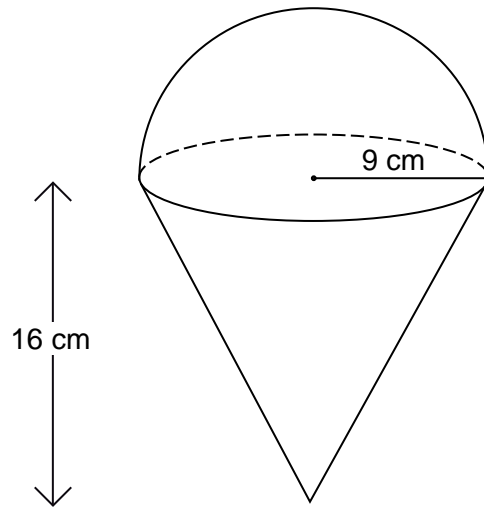

Work out the total volume of the toy.

[4 marks]

Answer _____ cm^3

END OF QUESTIONS



There are no questions printed on this page

**DO NOT WRITE ON THIS PAGE
ANSWER IN THE SPACES PROVIDED**

Copyright Information

For confidentiality purposes, from the November 2015 examination series, acknowledgements of third party copyright material will be published in a separate booklet rather than including them on the examination paper or support materials. This booklet is published after each examination series and is available for free download from www.aqa.org.uk after the live examination series.

Permission to reproduce all copyright material has been applied for. In some cases, efforts to contact copyright-holders may have been unsuccessful and AQA will be happy to rectify any omissions of acknowledgements. If you have any queries please contact the Copyright Team, AQA, Stag Hill House, Guildford, GU2 7XJ.

Copyright © 2016 AQA and its licensors. All rights reserved.

